

QSW-7600 Series Switches Hardware Installation and Reference Guide

QSW-7605, QSW-7608, QSW-7610

Table of contents

1 PRODUCT OVERVIEW	7
1.1 QSW-7608	7
1.2 QSW-7605	13
1.3 QSW-7610	18
1.4 Module	24
1.4.1 QSW-M7608-CM	24
1.4.2 QSW-M7605-CM	28
1.4.3 QSW-M7610-CM	30
1.4.4 QSW-M7600-24SFP/12GT4XS-EB	34
1.4.5 QSW-M7600-36GT12SFP4XS-EB	37
1.4.6 QSW-M7600-48GT4XS-EB	39
1.4.7 QSW-M7600-48SFP4XS-EB	41
1.4.8 QSW-M7600-24GT24SFP4XS-EB	44
1.4.9 QSW-M7600-32XS4QXS-DA	46
1.4.10 QSW-M7600-24XT4QXS-DA	49
1.4.11 QSW-M7610-FE-D I	51
1.4.12 QSW-PA1600I-F	52
1.4.13 QSW-PA600I-F	54
1.4.14 QSW-PD600I-F	56
1.4.15 QSW-PA300I-F	58
1.4.16 QSW-PA1600I	59
1.4.17 QSW-PA600I	60
1.4.18 QSW-PD1600I	62
1.4.19 QSW-PD600I	64
1.4.20 QSW-M76-PSE	65
1.4.21 QSW-PA3000I-PL	66
1.4.22 QSW-PA1600I-PL	68
1.4.23 QSW-M08-FAN	70
1.4.24 QSW-M05-FAN	72
1.4.25 QSW-M10-FAN	73
2 PREPARATION BEFORE INSTALLATION	75
2.1 Safety Suggestions	75
2.1.1 General Suggestions	75
2.1.2 Safety Precautions for Removal	75

2.1.3 Electrical Safety	75
2.1.4 Static Discharge Damage Prevention	76
2.1.5 Laser Safety	77
2.2 Installation Site Requirements	78
2.2.1 Load Bearing Requirements	78
2.2.2 Space Requirements	78
2.2.3 Ventilation Requirements	78
2.2.4 Temperature Requirements	78
2.2.5 Humidity Requirements	79
2.2.6 Cleanness Requirements	79
2.2.7 Power Requirements	80
2.2.8 System Grounding Requirements	82
2.2.9 EMI Consideration	82
2.3 Cabinet Mounting	83
2.4 Installation Tools	84
2.5 Precaution for Fiber Connection	85
2.6 Unpacking Requirements	85
3 PRODUCT INSTALLATION	86
3.1 Installation Procedure	86
3.2 Installation Verification	86
3.3 Installing the Air Filter (Optional)	87
3.4 Installing the PoE Frame (Optional)	88
3.5 Mounting Cable Management Brackets	89
3.6 Mounting the Cabinet	90
3.7 Mounting the Switch to a Cabinet	92
3.8 Connecting the System Ground	93
3.9 Installing Power Supplies	94
3.10 Installing Fans	96
3.11 Installing Modules	97
3.12 Installing Swappable Interface Modules (Optional)	100
3.12.1 Installing SFP+/SFP Modules	100
3.12.2 Installing SFP+ Cables	101
3.13 Connecting the Power Cord	102
3.14 Installation Verification	103

4 SYSTEM DEBUGGING	105
4.1 Establishing the Configuration Environment	105
4.2 Power-on Startup	107
5 MONITORING AND MAINTENANCE	108
5.1 QSW-7600 Monitoring	108
5.2 Hardware Maintenance	108
6 TROUBLESHOOTING	110
6.1 General Installation Troubleshooting Flow	110
6.2 Common Troubleshooting Procedures	111
7 REPLACING MODULES	114
7.1 Removing, Cleaning and Installing Air Filter	114
7.1.1 Removing, Cleaning and Installing Air Filters for Supervisor and Service Modules	114
7.2 Removing Swappable Interface Modules (Optional)	114
7.2.1 Removing SFP+/SFP Modules	114
7.2.2 Removing SFP+ Cables	115
7.3 Replacing Modules	115
7.4 Removing Power Modules	117
7.5 Removing Fans	119
7.6 Removing PoE Frame	120
8 CABLES	122
8.1 Connecting the External Port Cables	122
8.2 Bundling the Cables	122
9 APPENDIX A CONNECTORS AND MEDIA	123
10 APPENDIX B SWITCH LIGHTNING PROTECTION	125
11 APPENDIX C CABLING RECOMMENDATIONS IN INSTALLATION	128
12 APPENDIX D SITE SELECTION	132

Copyright Statement

QTECH©2020

QTECH reserves all copyrights of this document. Any reproduction, excerption, backup, modification, transmission, translation or commercial use of this document or any portion of this document, in any form or by any means, without the prior written consent of QTECH is prohibited.

Exemption Statement

This document is provided “as is”. The contents of this document are subject to change without any notice. Please obtain the latest information through the QTECH website. QTECH endeavors to ensure content accuracy and will not shoulder any responsibility for losses and damages caused due to content omissions, inaccuracies or errors.

Preface

Thank you for using our products. This manual will guide you through the installation of the device.

This manual describes the functional and physical features and provides the device installation steps, hardware troubleshooting, module technical specifications, and specifications and usage guidelines for cables and connectors.

Audience

It is intended for the users who have some experience in installing and maintaining network hardware. At the same time, it is assumed that the users are already familiar with the related terms and concepts.



Obtaining Technical Assistance

- ❖ QTECH Website: <https://www.qtech.ru>
- ❖ Technical Support Website: <https://helpdesk.qtech.ru>
- ❖ Technical Support Email: support@qtech.ru

Related Documents

Documents	Description
Configuration Guide	Describes network protocols and related mechanisms that supported by the product, with configuration examples.
Command Reference	Describes the related configuration commands, including command modes, parameter descriptions, usage guides, and related examples.

Symbol Conventions

-  Means reader take note. Notes contain helpful suggestions or references.
-  Means reader be careful. In this situation, you might do something that could result in equipment damage or loss of data.

1 PRODUCT OVERVIEW

Launched by QTECH independently, QSW-7600 series next generation core switches adopt the crossbar/FULLMESH architecture and support dual supervisor modules and power supply redundancy.

- ❖ The QSW-7608: supports dual supervisor modules and provides six service module slots.
- ❖ The QSW-7605: supports dual supervisor modules and provides three service module slots.
- ❖ The QSW-7610: supports dual supervisor modules and provides eight service module slots and two switch fabric slots.

1.1 QSW-7608

Specifications

Model	QSW-7608
Module Slot	two supervisor module slots and six service module slots
Supervisor Module	QSW-M7608-CM
Supervisor Module Redundancy	Supported
Service Module	QSW-M7600-24SFP/12GT4XS-EB QSW-M7600-36GT12SFP4XS-EB QSW-M7600-48GT4XS-EB QSW-M7600-48GT4XS-P-EB QSW-M7600-48SFP4XS-EB
Hot Swapping	Supported
Power Supply Module	QSW-PA600I-F: 90-180V~ power: 600W; 180-264V~ power: 600W QSW-PA1600I-F: 90-180V~ power: 1200W; 180-264V~ power: 1600W QSW-PD600I-F: -40- -75V~ power: 600W; QSW-PA3000I-PL: 90-176V~ power: 1200W; 176-210V~ power: 2500W; 210-264V~ power: 3000W QSW-PA1600I-PL: 90-176V~ power: 1200W;

	176-264V~ power: 1600W
Power Supply Redundancy	The power supply redundancy of the same model is supported
Fan Module	QSW-M08-FAN
EMC Standards	GB9254-2008 CLASS A, FCC CLASS A
Safety Standards	GB4943-2011
Altitude	Long term operation height: 3000m at 50°C. The temperature decreases by 1°C as the altitude ranging from 3000m to 5000m increases by 200m.
	Operation height: 5000m max
	Storage height: 5000m max
Operating Temperature	0°C to 50°C
Storage Temperature	-40°C to 70°C
Operating Humidity	10% to 90% RH (non-condensing)
MTBF	216,000 hours
Noise	55.9 dB at 35°C 73.4 dB at 50°C
Weight	Net weight: 32.35 kg (including the chassis and fans)
Dimensions (W x D x H)	442 mm x 465 mm x 441.7 mm (cable management brackets excluded), 10U

 The weight only includes that of the empty chassis and fans. The whole device's weight is subject to that of the modules selected.

 QSW-7608 switch is a class A product. In a domestic environment, this product may cause radio interference in which case the user may be required to take adequate measures.

Product Appearance

The hardware system of the QSW-7608 switch is composed of the chassis, the power system, modules and the cooling system.

- ❖ The power system provides four power supply slots and supports N+N power redundancy. After QSW-M76-PSE or QSW-M76-PSE-L is configured, two PoE power slots are available. PoE power supports 1+1 power redundancy. Users are recommended to configure redundancy for the power supplies.
- ❖ The QSW-7608 switch provides two supervisor module slots and six service module slots. The supervisor modules support 1+1 redundancy. Users are recommended to configure redundancy for the supervisor modules. Users may choose different service modules as needed.
- ❖ The cooling system is composed of the fan trays and air filters. Fan trays are at the back of the chassis. The air filters are on the right side of the chassis.

Figure 1-1 Appearance of the QSW-7608 Switch

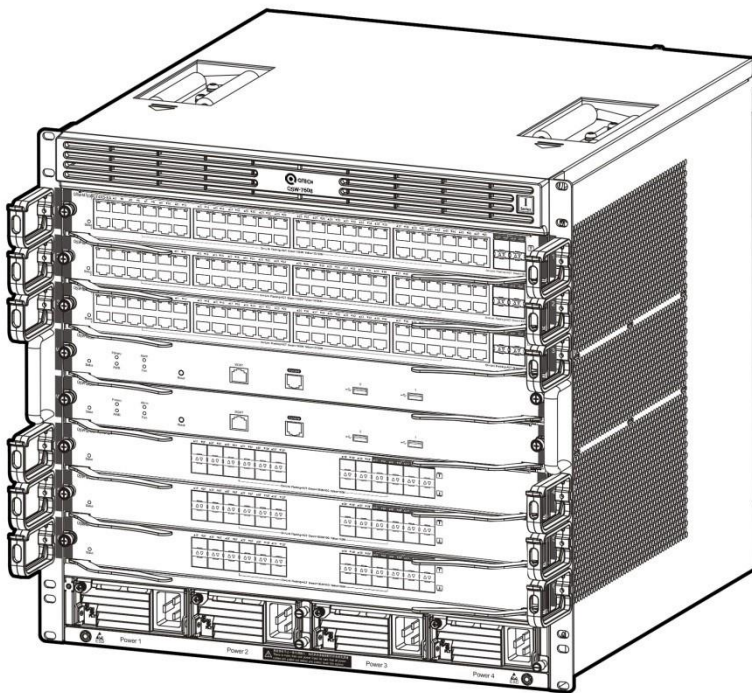

Front Panel

The front panel of the QSW-7608 switch is shown in Figure 1-2.

Figure 1-2 Front Panel of the QSW-7608 Switch

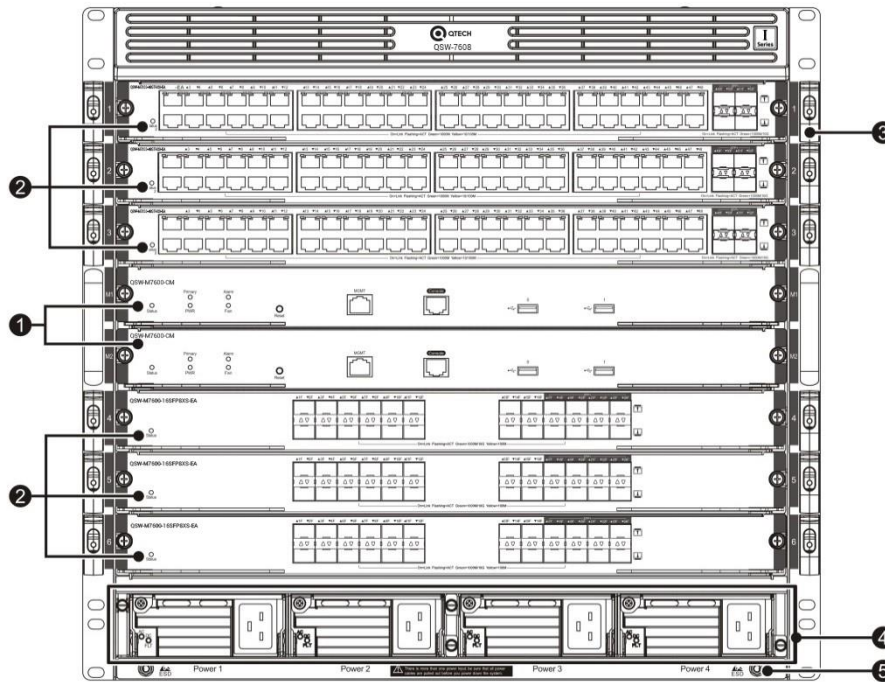

<p>Note:</p>	<ol style="list-style-type: none"> 1. Supervisor module slots 2. Service module slots 3. Cable management bracket 	<ol style="list-style-type: none"> 4. Slot for system power supply module 5. Anti-static wrist strap socket
--------------	--	---

⚠ Ensure the supervisor module, service module, and power supply module are removed from the chassis before you move or transport the QSW-7608 chassis.

Back Panel

The back panel of the QSW-7608 switch is shown in Figure 1-3.

Figure 1-3 Back Panel of the QSW-7608 Switch

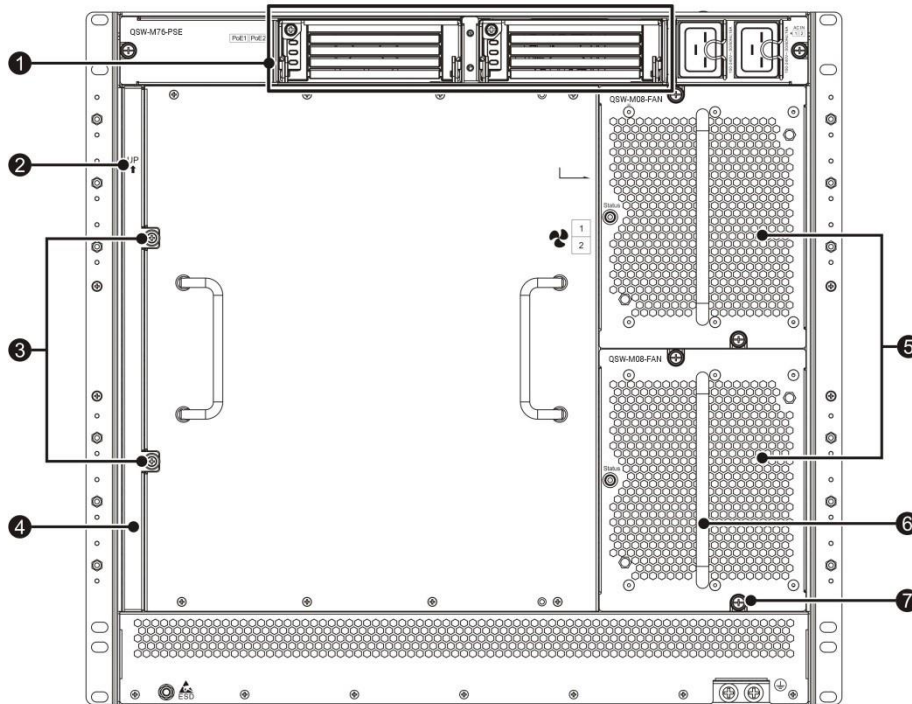

<p>Note:</p>	<ol style="list-style-type: none"> 1. PoE power supply slot 2. Direction sign for installing air filter 3. Captive screw of the air filter 4. Air filter module 	<ol style="list-style-type: none"> 5. Fan Tray 6. Handle of the fan tray 7. Captive screws of the fan tray
--------------	---	---

! For QSW-7608, the PoE power supply slot consists of a frame of PoE power supply module - QSW-M76-PSE. For more information, please refer to *QSW-M76-PSE*. If PoE power supply input is in demand, you need to purchase a frame so as to install a PoE power supply module.

Power supply

The QSW-7608 switch adopts both AC and PoE power supply input.

- ❖ AC power supply input: The QSW-PA1600I-F and the QSW-PA600I-F power supply modules are supported. The two types of power supply modules support power management. The supervisor module of the QSW-7608 switch can read the power supply information and implement flexible and intelligent power management.
- ❖ PoE power supply input: The QSW-PA3000I-PL and the QSW-PA1600I-PL power supply modules are supported. The two types of power supply modules support power management. The supervisor module of the QSW-7608 switch can read the power supply information and implement flexible and intelligent power management.

i The QSW-7608 switch supports N+N power supply redundancy to improve the system stability and reliability. We recommend users to configure N+M redundancy for power supply modules.

Heat Dissipation System

The operating environment temperature of the QSW-7608 switch ranges between 0 and 50°C. The thermal design must satisfy the requirement on the device's reliability in the temperature range while ensuring the device's safety and maintainability. According to the thermal design of the QSW-7608 switch, fans are used to draw air for forced convection cooling in order to ensure that the device works properly in the specified environment.

Figure 1-4 Ventilation and Heat Dissipation System of the QSW-7608 Switch (Air Intakes)

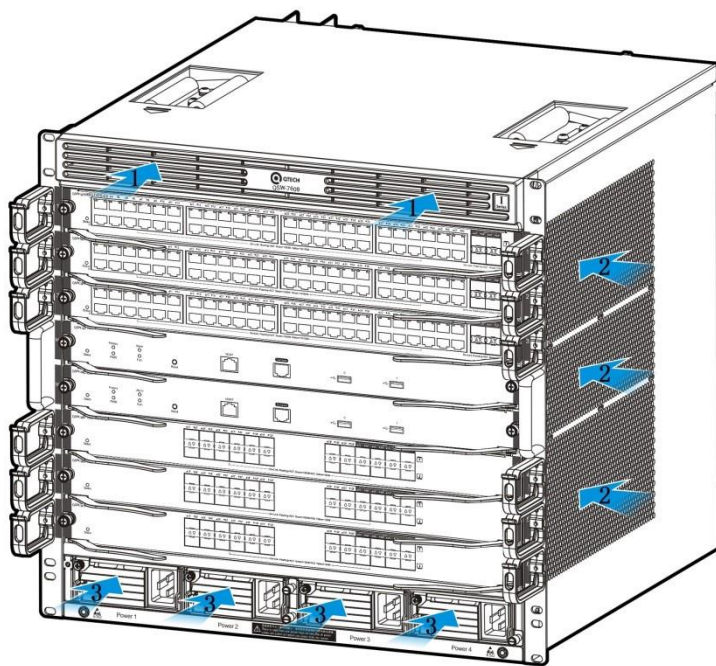

Note:	<ol style="list-style-type: none"> 1. Air intakes for PoE power modules 2. Air intakes for service and supervisor modules 	<ol style="list-style-type: none"> 3. Air intakes for system power modules
-------	---	---

Figure 1-5 Ventilation and Heat Dissipation System of the QSW-7608 Switch (Exhaust Vents)

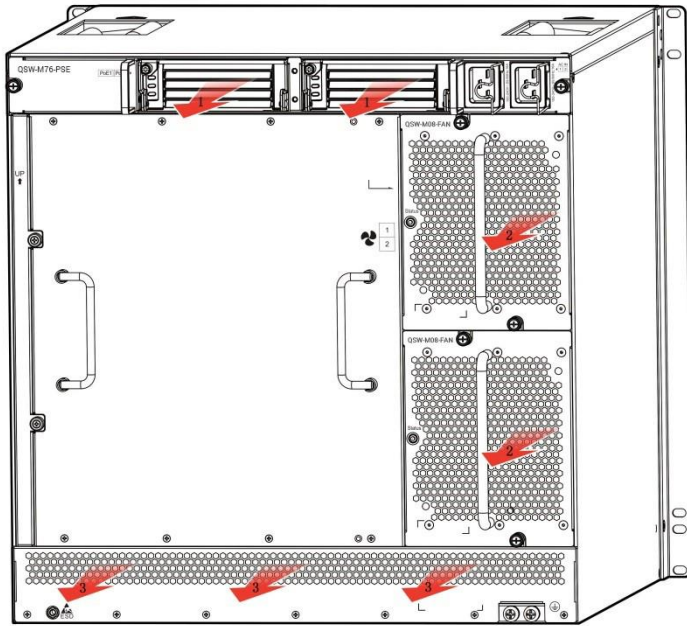

Note:	1. Exhaust vents for PoE power modules 2. Exhaust vents for service and supervisor modules	3. Exhaust vents for system power modules
-------	---	---

For the PoE power supply modules, air flows across the chassis from the back intakes to the front vents.

For the supervisor and service modules, air flows across the chassis from the right intakes to the back vents.

For the power supply modules, air flows in from the front intakes and out from the back vents.

i The chassis should be mounted in a place with sufficient space for air circulation. Maintain a minimum clearance of 10cm around the chassis.

i If any module slot is unoccupied, install a filler panel to ensure proper airflow.

1.2 QSW-7605

Specifications

Model	QSW-7605
Module Slot	two supervisor module slots and three service module slots
Supervisor	QSW-M7605-CM

Module	
Supervisor Module Redundancy	Supported
Service Module	QSW-M7600-24SFP/12GT4XS-EB QSW-M7600-36GT12SFP4XS-EB QSW-M7600-48GT4XS-EB QSW-M7600-48GT4XS-P-EB QSW-M7600-48SFP4XS-EB
Hot Swapping	Supported
Power Supply Module	QSW-PA300I-F: 90-290V~ power: 300W; 192-290V~ power: 300W
Power Supply Redundancy	The power supply redundancy of the same model is supported.
Fan Module	QSW-M05-FAN
EMC Standards	GB9254-2008 CLASS A, FCC CLASS A
Safety Standards	GB4943-2011
Altitude	Long term operation height: 3000m at 50°C. The temperature decreases by 1°C as the altitude ranging from 3000m to 5000m increases by 200m.
	Operation height: 5000m max
	Storage height: 5000m max
Operating Temperature	0°C to 50°C
Storage Temperature	-40°C to 70°C
Operating Humidity	10% to 90% RH (non-condensing)
MTBF	200,000 hours

Noise	64.3 dB at 35°C 70.3 dB at 50°C
Weight	Net weight: 12.42 kg (including the chassis and fans)
Dimensions (W x D x H)	442 mm x 451 mm x 175 mm (cable management brackets excluded), 4U

- i The weight only includes that of the empty chassis and fans. The whole device's weight is subject to that of the modules selected.
- ! QSW-7605 switch is a class A product. In a domestic environment, this product may cause radio interference in which case the user may be required to take adequate measures.

Product Appearance

The hardware system of the QSW-7605 switch is composed of the chassis, the power system, modules and the cooling system.

- ❖ The power system provides two power supply slots and supports 1+1 power supply redundancy. Users are recommended to configure redundancy for the power supplies.
- ❖ The QSW-7605 switch provides two supervisor module slots and three service module slots. The supervisor modules support 1+1 redundancy. Users are recommended to configure redundancy for the supervisor modules. Users may choose different service modules as needed.
- ❖ The cooling system is composed of the fan trays. Fan trays are at the back of the chassis.

Figure 1-65 Appearance of the QSW-7605 Switch

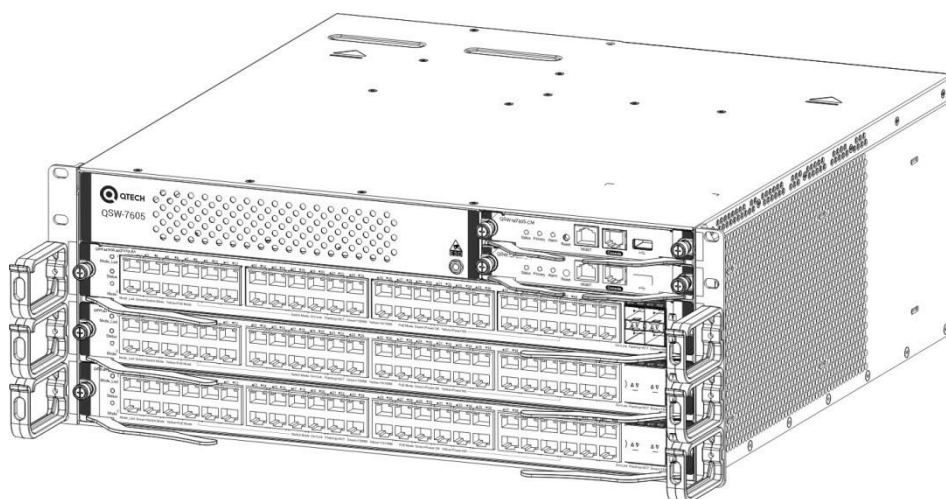

Front Panel

The front panel of the QSW-7605 switch is shown in Figure 1-7.

Figure 1-7 Front Panel of the QSW-7605 Switch

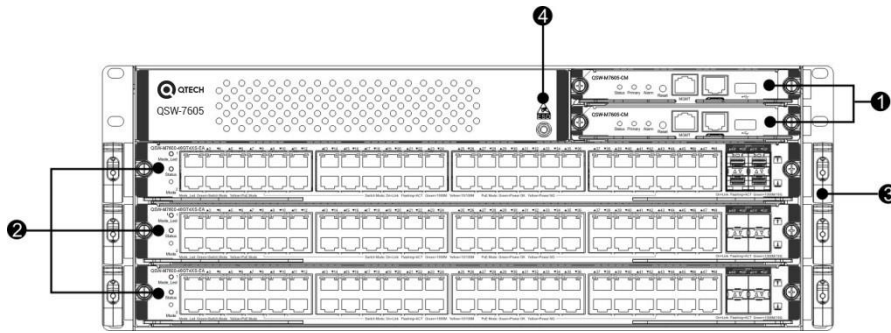

Note:	1. Supervisor module slot	4. Anti-static wrist strap socket
	2. Service module slots	
	3. Cable management bracket	

⚠ Ensure the supervisor module, service module, and power supply module are removed from the chassis before you move or transport the QSW-7605 chassis.

Back Panel

The back panel of the QSW-7605 switch is shown in Figure 1-8.

Figure 1-8 Back Panel of the QSW-7605 Switch

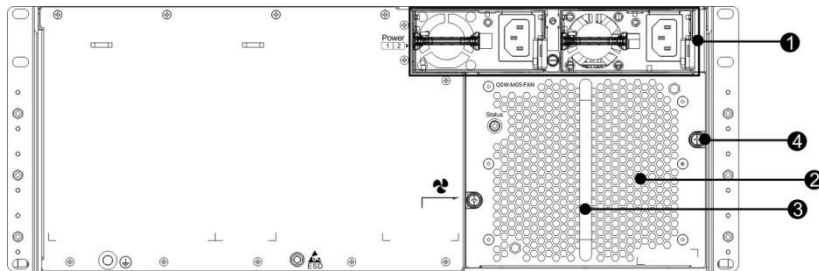

Note:	1. Power module slot	4. Captive screws of the fan tray
	2. Fan tray	
	3. Handle of the fan tray	

Power supply

The QSW-7605 switch adopts the AC power supply.

- ❖ AC power supply input: the QSW-PA300I-F power supply module is supported. This type of power supply module support power management. The supervisor module of the QSW-7605 switch can read the power supply information and implement flexible and intelligent power management.

Heat Dissipation System

The operating environment temperature of the QSW-7605 switch ranges between 0 and 50°C. The thermal design must satisfy the requirement on the device's reliability in the temperature range while ensuring the device's safety and maintainability. According to the thermal design

of the QSW-7605 switch, fans are used to draw air for forced convection cooling in order to ensure that the device works properly in the specified environment.

Figure 1-9 Ventilation and Heat Dissipation System of the QSW-7605 Switch (Air Intakes)

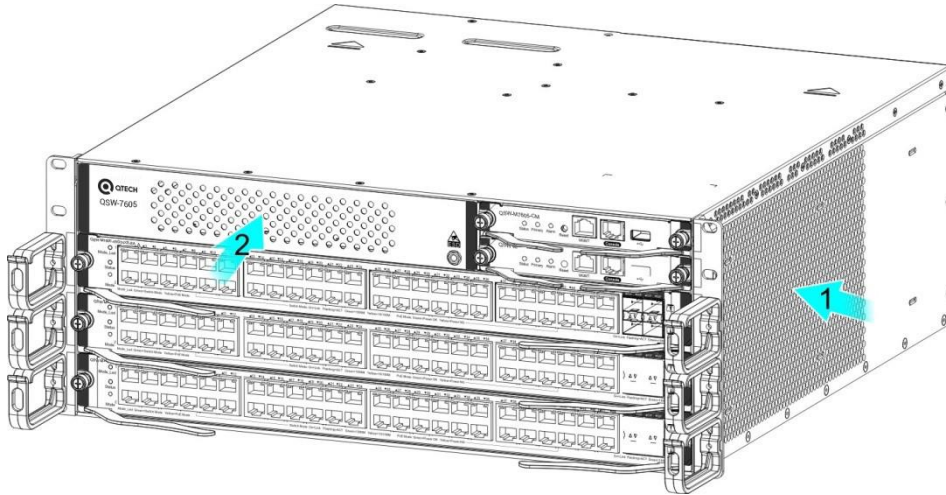

Note:	1. Air intakes for service and supervisor modules	2. Air intakes for system power modules
-------	---	---

Figure 1-10 Ventilation and Heat Dissipation System of the QSW-7605 Switch (Exhaust Vents)

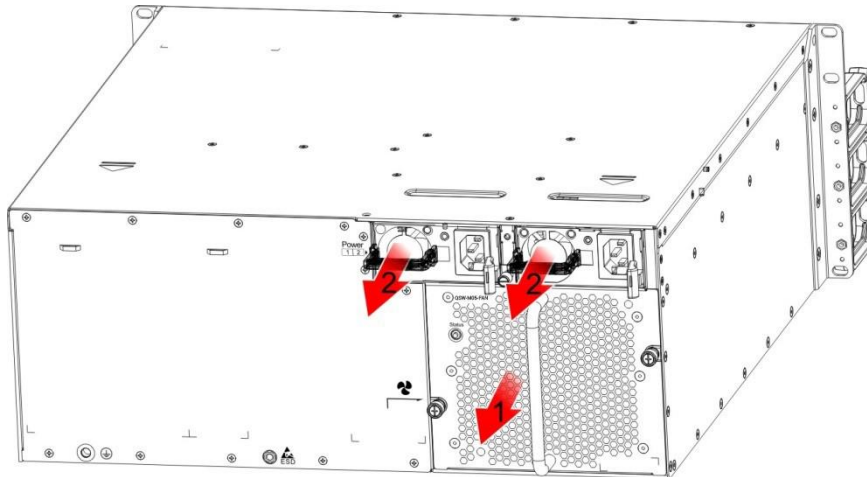

Note:	1. Exhaust vents for service and supervisor modules	2. Exhaust vents for system power modules
-------	---	---

For the supervisor and service modules, air flows across the chassis from the right intakes to the back vents.

For the power supply modules, air flows in from the front intakes and out from the back vents.



- i The chassis should be mounted in a place with sufficient space for air circulation. Maintain a minimum clearance of 10cm around the chassis.
- i If any module slot is unoccupied, install a filler panel to ensure proper airflow.

1.3 QSW-7610

Specifications

Model	QSW-7610
Module Slot	two supervisor module slots, eight service module slots and two switching fabric module slots
Supervisor Module	QSW-M7610-CM
Supervisor Module Redundancy	Supported
Service Module	QSW-M7600-32XS4QXS-DA QSW-M7600-24XT4QXS-DA QSW-M7600-24GT24SFP4XS-EB QSW-M7600-24SFP/12GT4XS-EB QSW-M7600-48GT4XS-EB QSW-M7600-48SFP4XS-EB QSW-M7600-36GT12SFP4XS-EB
Hot Swapping	Supported
Power Supply Module	QSW-PA600I: 90-180V~ Power: 600W; 180-264V~ Power: 600W QSW-PA1600I: 90-180V~ Power: 1200W; 180-264V~ Power: 1600W QSW-PD600I: -40VDC to -75VDC Power: 600W QSW-PD1600I: -40VDC to -75VDC Power: 1400W
Power Supply Redundancy	The power supply redundancy of the same model is supported.
Fan Module	QSW-M10-FAN
EMC Standards	GB9254-2008 CLASS A, FCC CLASS A

Safety Standards	GB4943-2011
Altitude	Long term operation height: 3000m at 50°C. The temperature decreases by 1°C as the altitude ranging from 3000m to 5000m increases by 200m.
	Operation height: 5000m max
	Storage height: 5000m max
Operating Temperature	0°C to 50°C
Storage Temperature	-40°C to 70°C
Operating Humidity	10% to 90% RH (non-condensing)
MTBF	342,000 hours
Noise	60 dB at 35°C 75 dB at 50°C
Weight	Net weight: 43.55 kg (including the chassis and fans)
Dimensions (W x D x H)	442.5 mm x 560 mm x 442 mm (cable management brackets excluded), 10U 442.5 mm x 662 mm x 442 mm (cable management brackets excluded), 10U

-  The weight only includes that of the empty chassis and fans. The whole device's weight is subject to that of the modules selected.
-  Service slot 8 of QSW-7610 switch does not support EB module.
-  QSW-7610 switch is a class A product. In a domestic environment, this product may cause radio interference in which case the user may be required to take adequate measures.

Product Appearance

The hardware system of the QSW-7610 switch is composed of the chassis, the power system, modules and the cooling system.

- ❖ The power system provides four power supply slots and supports n+n power supply redundancy. Users are recommended to configure redundancy for the power supplies.
- ❖ The QSW-7610 switch provides two supervisor module slots, eight service module slots and two switching fabric module slots. The supervisor modules support 1+1 redundancy. Users are recommended to configure redundancy for the supervisor modules. Users may choose different service modules as needed.

❖ The cooling system is composed of the fan trays. Fan trays are at the back of the chassis.

Figure 1-11 Appearance of the QSW-7610 Switch

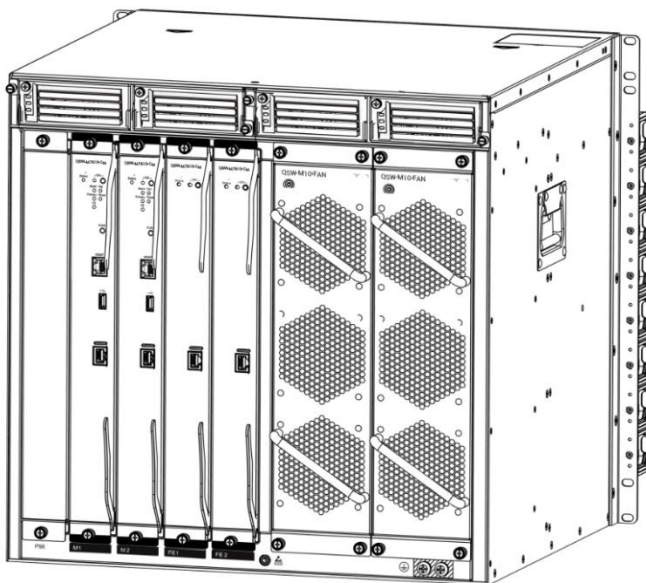
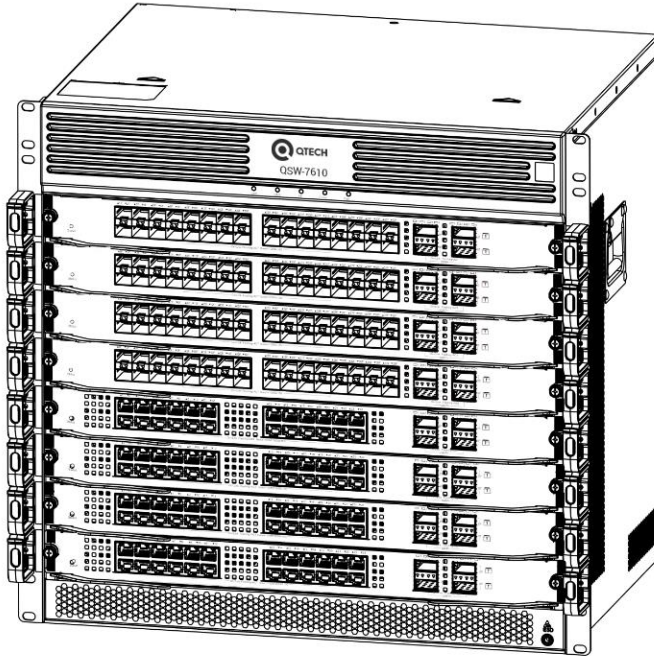

Front Panel

The front panel of the QSW-7610 switch is shown in Figure 1-12.

Figure 1-12 Front Panel of the QSW-7610 Switch

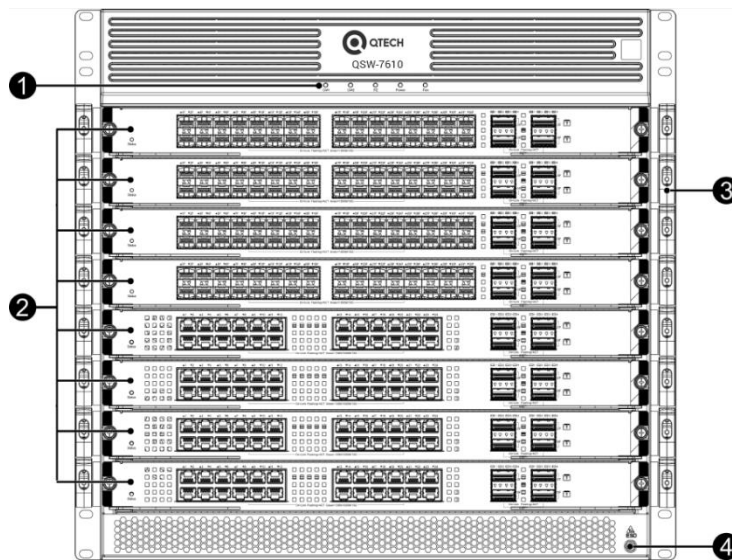

Note:	1. System status LED	3. Cable management bracket
	2. Service module slots	

LED

LED	Identification on the panel	Status	Meaning
Supervisor module 1 status	CM1	Off	The module is NOT receiving power.
		Solid Red	The module is faulty.
		Blinking Green	Initiation is in progress. Continuous blinking indicates a failure.
		Solid Green	Initiation is complete.
Supervisor module 2 status	CM2	Off	The module is NOT receiving power.
		Solid Red	The module is faulty.
		Blinking Green	Initiation is in progress. Continuous blinking indicates a failure.
		Solid Green	Initiation is complete.
Switching fabric module status	FE	Off	The module is NOT in position or NOT receiving power.
		Solid Green	The module is operational.

		Solid Red	The module is faulty.
Power status	Power	Off	The module is NOT in position.
		Solid Green	The module is operational.
		Solid Red	A failure occurred or the power cable is plugged out.
Fan status	Fan	Solid Green	The module is operational.
		Solid Yellow	The module is NOT in position or removed.
		Solid Red	The module is faulty.

Back Panel

The back panel of the QSW-7610 switch is shown in Figure 1-13.

Figure 1-13 Back Panel of the QSW-7610 Switch

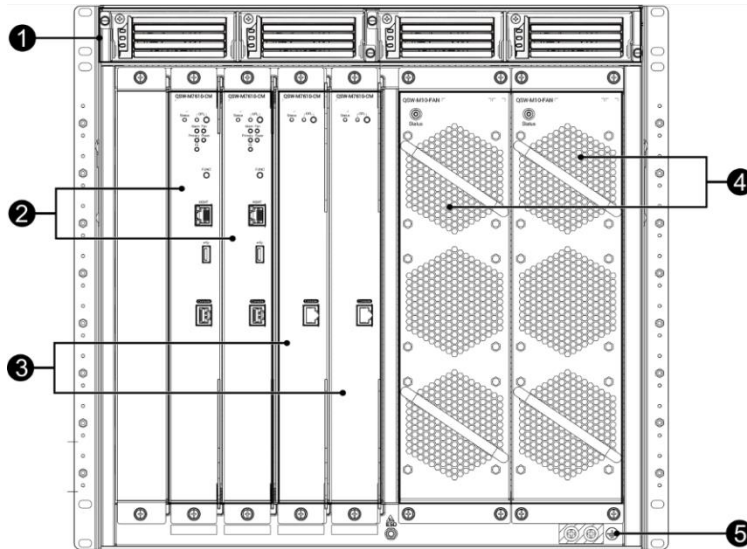

Note:	<p>1. Power module slot</p> <p>2. Supervisor module slot</p> <p>3. Switching fabric module slot</p>	<p>4. Fan module slot</p> <p>5. Grounding point</p>
-------	---	---

⚠ Ensure the supervisor module, service module, and power supply module are removed from the chassis before you move or transport the QSW-7610 chassis.

Power supply

The QSW-7610 switch adopts the AC and DC power supply.

- ❖ AC power supply input: The QSW-PA1600I and the QSW-PA600I power supply modules are supported. The two types of power supply modules support power management. The supervisor module of the QSW-7610 switch can read the power supply information and implement flexible and intelligent power management.
- ❖ DC power supply input: The QSW-PD1600I and the QSW-PD600I power supply modules are supported. The two types of power supply modules support power management. The supervisor module of the QSW-7610 switch can read the power supply information and implement flexible and intelligent power management.

Heat Dissipation System

The operating environment temperature of the QSW-7610 switch ranges between 0 and 50°C. The thermal design must satisfy the requirement on the device's reliability in the temperature range while ensuring the device's safety and maintainability. According to the thermal design of the QSW-7610 switch, fans are used to draw air for forced convection cooling in order to ensure that the device works properly in the specified environment.

Figure 1-14 Ventilation and Heat Dissipation System of the QSW-7610 Switch (Air Intakes)

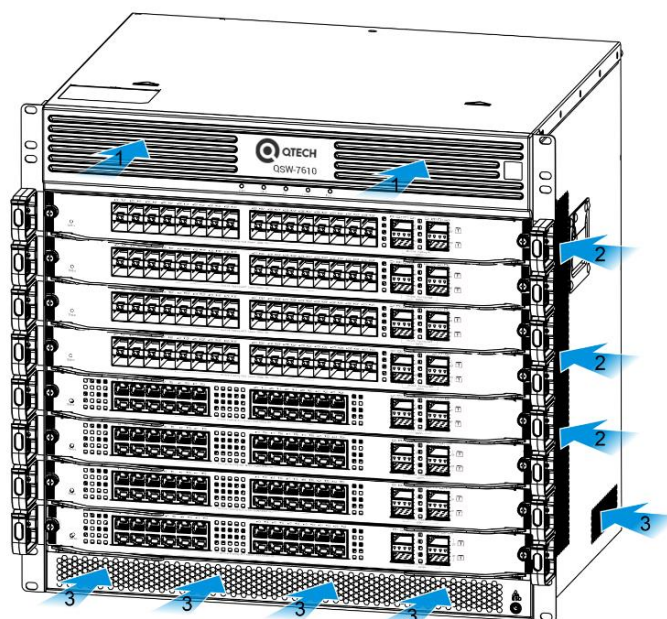

Note:	1. Air intakes for power modules 2. Air intakes for service modules	3. Air intakes for supervisor and switching fabric modules
-------	--	--

Figure 1-15 Ventilation and Heat Dissipation System of the QSW-7610 Switch (Exhaust Vents)

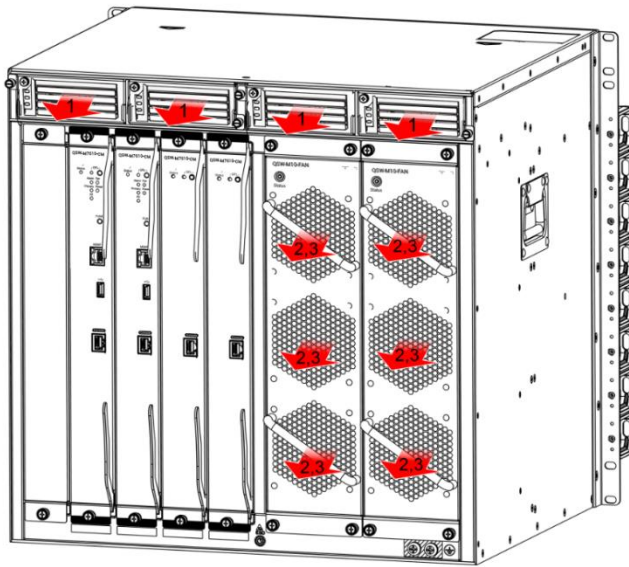

Note:	1. Exhaust vents for power modules	2.3. Exhaust vents for service, supervisor and switching fabric modules
-------	------------------------------------	---

For the service modules, air flows across the chassis from the right intakes to the back vents.

For the power supply modules, air flows in from the front intakes and out from the back vents.

For the supervisor and switching fabric modules, air flows in from the bottom to the back vents.

- i The chassis should be mounted in a place with sufficient space for air circulation. Maintain a minimum clearance of 10cm around the chassis.
- i If any module slot is unoccupied, install a filler panel to ensure proper airflow.

1.4 Module

The QSW-7600 switch adopts the module-based design. Compliant with industry standards, the design divides modules and integrates module interfaces to ensure the switch system's functioning and independence of various function modules.

The modules of the QSW-7600 switch provide 10/100/1000M auto-sensing Ethernet copper ports, 1000 Mbps/100 Mbps SFP (single-mode/multi-mode) optical fiber interfaces and 10G/40G optical fiber interfaces.

1.4.1 QSW-M7608-CM

QSW-M7608-CM is the supervisor module of the QSW-7608 series switches and is designed with management and switching functions.

Module Appearance

Figure 1-16 Appearance of the QSW-M7608-CM Module

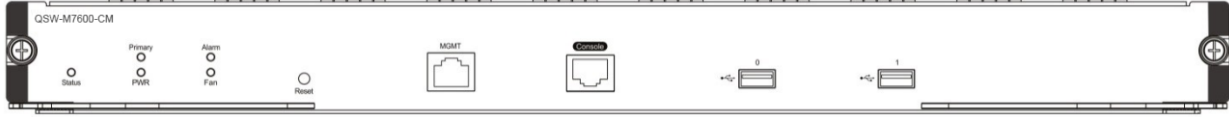

External Port

The QSW-M7608-CM module provides three external ports:

- ❖ Universal Serial Bus (USB) port: By connecting to the USB port, the USB storage devices can store logs, host version, alarms and other diagnosis information, facilitating online upgrade of switch software and storage of logs.

i To secure data and prevent damage to the device, it is recommended to use high-quality flash disks produced by reliable manufacturers. The USB port is compatible with most USB controllers but may be unable to identify some USB disk models.

- ❖ Console port: As a serial communications port, it uses the RS-232 interface level and standard RJ-45 connector. This port is used to connect the device to serial ports of background terminal computers to perform tasks including system commissioning, configuration, maintenance, management, and host software loading.
- ❖ 10/100/1000M MGMT port: As the 10/100/1000BASE-T Ethernet port, it uses the RJ-45 connector. This port can be used to connect the device to the Ethernet port of the background computer to load programs. Use the standard cable to connect the device to the Ethernet port of the background computer.

Button

The QSW-M7608-CM module provides a Reset button, which is used to reset the system. If the button is held for less than five seconds, it is a short press; if the button is held for five seconds or longer, it is a long press.

- i** In case of a short press, the Status LED flashes in green, and the device resets within five seconds after the press. In case of a long press, the Status LED flashes in green and then flashes in red; the device resets within five seconds after the press.
- i** Press the button, and the system starts to collect information, during which the device will not restart. After the collection is complete, the device restarts automatically. Hold the button for a while and release it, the device restarts automatically in five seconds.

LED

LED	Identification on the panel	Status	Meaning
System LED	Status	Off	The module is NOT receiving power.
		Solid red	The module is faulty.

		Blinking green	Initialization is in progress. Continuous blinking indicates errors.
		Solid green	The module is operational.
Primary/standby supervisor module LED	Primary	Off	The module acts as the standby supervisor module.
		Solid green	The module acts as the primary supervisor module.
Fault alarm LED	Alarm	Off	No fault
		Solid red	The system fails, interrupting functioning of the whole system or a module; the device may be damaged if it continues operating.
		Solid yellow	The device overheats, which will affect the system performance. The system may continue operating.
Fan status LED	FAN	Solid green	The fan is operational.
		Solid yellow	The fan is NOT in the position.
		Solid red	The fan is faulty.
Power status LED	PWR	Off	The power supply module is NOT in the position.
		Solid green	The power supply module is operational.
		Solid red	The power supply module is faulty.
MGMT port status LED	MGMT	Off	The MGMT port is NOT connected.
		Green	The MGMT port is connected at 1000Mbps.
		Yellow	The MGMT port is connected at 10/100Mbps.
		Blinking	The MGMT port is transmitting or receiving data.

Specifications

Model	QSW-M7608-CM
CPU	Quad-core CPU, each core with the clock speed of 1.0G
BOOTROM	8 MB
Flash Memory	8 GB
SDRAM	DDRIII 4 GB
External Port	One Console port; One 10/100/1000M MGMT port; Two USB ports
Button	One Reset button
Power Consumption	<65W
Hot Swapping	Supported
Management Redundancy	Supported
EMC Standards	GB9254-2008 CLASS A
Safety Standards	GB4943-2011
Operating Temperature	0°C to 50°C
Storage Temperature	-40°C to 70°C
Operating Humidity	10% to 90% RH (non-condensing)
MTBF	312,000 hours
Weight	Net weight: 2.1 kg
Dimensions (W x D x H)	438.5 mm x 309.0 mm x 40.1 mm

⚠ The QSW-M7608-CM adopts the CR2032 lithium battery. The device may explode if a wrong battery model is used. Used batteries should be properly disposed of.

1.4.2 QSW-M7605-CM

QSW-M7605-CM is the supervisor module of the QSW-7605 series switches and is designed with management and switching functions.

Module Appearance

Figure 1-17 Appearance of the QSW-M7605-CM Module

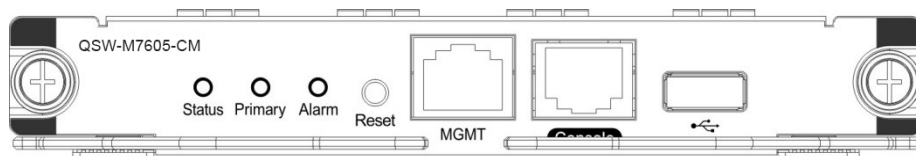

External Port

The QSW-M7600-CM module provides three external ports:

❖ **Universal Serial Bus (USB) port:** By connecting to the USB port, the USB storage devices can store logs, host version, alarms and other diagnosis information, facilitating online upgrade of switch software and storage of logs.

i To secure data and prevent damage to the device, it is recommended to use high-quality flash disks produced by reliable manufacturers. The USB port is compatible with most USB controllers but may be unable to identify some USB disk models.

❖ **Console port:** As a serial communications port, it uses the RS-232 interface level and standard RJ-45 connector. This port is used to connect the device to serial ports of background terminal computers to perform tasks including system commissioning, configuration, maintenance, management, and host software loading.

❖ **10/100/1000M MGMT port:** As the 10/100/1000BASE-T Ethernet port, it uses the RJ-45 connector. This port can be used to connect the device to the Ethernet port of the background computer to load programs. Use the standard cable to connect the device to the Ethernet port of the background computer.

Button

The QSW-M7605-CM module provides a Reset button, which is used to reset the system. If the button is held for less than five seconds, it is a short press; if the button is held for five seconds or longer, it is a long press.

i In case of a short press, the Status LED flashes in green, and the device resets within five seconds after the press. In case of a long press, the Status LED flashes in green and then flashes in red; the device resets within five seconds after the press.

i Press the button, and the system starts to collect information, during which the device will not restart. After the collection is complete, the device restarts automatically. Hold the button for a while and release it, the device restarts automatically in five seconds.

LED

LED	Identification on the panel	Status	Meaning
System LED	Status	Off	The module is NOT receiving power.
		Solid red	The module is faulty.
		Blinking green	Initialization is in progress. Continuous blinking indicates errors.
		Solid green	The module is operational.
Primary/standby supervisor module LED	Primary	Off	The module acts as the standby supervisor module.
		Solid green	The module acts as the primary supervisor module.
Alarm LED	Alarm	Off	No fault
		Solid red	The system fails, interrupting functioning of the whole system or a module; the device may be damaged if it continues operating.
		Solid yellow	The device overheats, which will affect the system performance. The system may continue operating.
MGMT port status LED	MGMT	Off	The MGMT port is NOT connected.
		Green	The MGMT port is connected at 1000Mbps.
		Yellow	The MGMT port is connected at 10/100Mbps.
		Blinking	The MGMT port is transmitting or receiving data.

Specifications

Model	QSW-M7605-CM
CPU	Quad-core CPU, each core with the clock speed of 1.0G
BOOTROM	8 MB

Flash Memory	1 GB
SDRAM	DDRIII 4 GB
External Port	One Console port; One 10/100/1000M MGMT port; One USB port
Button	One Reset button
Power Consumption	<33W
Hot Swapping	Supported
Management Redundancy	Supported
EMC Standards	GB9254-2008 CLASS A
Safety Standards	GB4943-2011
Operating Temperature	0°C to 50°C
Storage Temperature	-40°C to 70°C
Operating Humidity	10% to 90% RH (non-condensing)
MTBF	312,000 hours
Weight	Net weight: 0.86 kg
Dimensions (W x D x H)	151.0 mm x 309.0 mm x 23.64 mm

 The QSW-M7605-CM adopts the CR2032 lithium battery. The device may explode if a wrong battery model is used. Used batteries should be properly disposed of.

1.4.3 QSW-M7610-CM

QSW-M7610-CM is the supervisor module of the QSW-7610 series switches and is designed with management and switching functions.

Module Appearance

Figure 1-18 Appearance of the QSW-M7610-CM Module

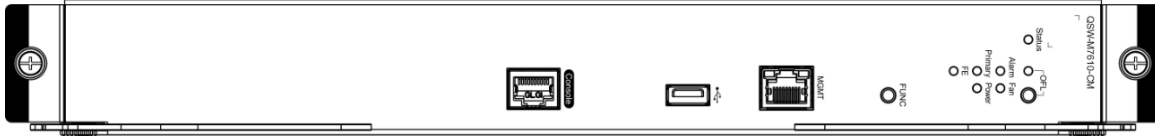

External Port

The QSW-M7610-CM module provides three external ports:

- ❖ Universal Serial Bus (USB) port: By connecting to the USB port, the USB storage devices can store logs, host version, alarms and other diagnosis information, facilitating online upgrade of switch software and storage of logs.

i To secure data and prevent damage to the device, it is recommended to use high-quality flash disks produced by reliable manufacturers. The USB port is compatible with most USB controllers but may be unable to identify some USB disk models.

- ❖ Console port: As a serial communications port, it uses the RS-232 interface level and standard RJ-45 connector. This port is used to connect the device to serial ports of background terminal computers to perform tasks including system commissioning, configuration, maintenance, management, and host software loading.
- ❖ 10/100/1000M MGMT port: As the 10/100/1000BASE-T Ethernet port, it uses the RJ-45 connector. This port can be used to connect the device to the Ethernet port of the background computer to load programs. Use the standard cable to connect the device to the Ethernet port of the background computer.

Button

The QSW-M7610-CM module provides two buttons.

- ❖ FUNC button: It is used to reset the system. If the button is held for less than five seconds, it is a short press; if the button is held for five seconds or longer, it is a long press.

i Press the button, and the system starts to collect information, during which the device will not restart. After the collection is complete, the device restarts automatically. Hold the button for a while and release it, the device restarts automatically in five seconds.

- ❖ OFL button: Press the button for about five seconds and release the button. When the LED turns green, you can remove the FE card. Otherwise, packet loss may occur.

i When there is only one supervisor module, the OFL button will lose effect.

LED

LED	Identification on the panel	Status	Meaning
System LED	Status	Off	The module is NOT receiving power.

		Solid red	The module is faulty.
		Blinking green	Initialization is in progress. Continuous blinking indicates errors.
		Solid green	The module is operational.
Primary/standby supervisor module LED	Primary	Off	The module acts as the standby supervisor module.
		Solid green	The module acts as the primary supervisor module.
Alarm LED	Alarm	Off	No fault
		Solid red	The system fails, interrupting functioning of the whole system or a module; the device may be damaged if it continues operating.
		Solid yellow	The device overheats, which will affect the system performance. The system may continue operating.
Fan status LED	Fan	Solid Green	The fan module is operational.
		Solid Yellow	The fan module is not in position or powered off.
		Solid Red	A failure occurred.
Power status LED	Power	Off	The power module is not in position.
		Solid Green	The power module is operational.
		Solid Red	A failure occurred.
Switching fabric module LED	FE	Off	The switching fabric module is not in position or powered off.
		Solid Green	The switching fabric module is operational.
		Solid Red	A failure occurred.

MGMT port status LED	MGMT	Off	The MGMT port is NOT connected.
		Green	The MGMT port is connected at 1000Mbps.
		Yellow	The MGMT port is connected at 10/100Mbps.
		Blinking	The MGMT port is transmitting or receiving data.
Offline LED	OFL	Off	Switching service is in progress. The module cannot be removed.
		Green	Release the Offline button and wait for 2s before removing the module.

Specifications

Model	QSW-M7610-CM
CPU	Quad-core CPU, each core with the clock speed of 1.5G
BOOTROM	16 MB
Flash Memory	8 GB
SDRAM	DDR4 4GB
External Port	One Console port; One 10/100/1000M MGMT port; One USB port
Button	One FUNC button and one OFL button
Power Consumption	<50W
Hot Swapping	Supported
Management Redundancy	Supported
EMC Standards	GB9254-2008 CLASS A
Safety Standards	GB4943-2011

Operating Temperature	0°C to 50°C
Storage Temperature	-40°C to 70°C
Operating Humidity	10% to 90% RH (non-condensing)
MTBF	342,000 hours
Weight	Net weight: 1.9 kg
Dimensions (W x D x H)	371.0 mm x 248.0 mm x 43.0 mm

- i** The QSW-M7610-CM adopts the CR2032 lithium battery. The device may explode if a wrong battery model is used. Used batteries should be properly disposed of.

1.4.4 QSW-M7600-24SFP/12GT4XS-EB

Module Appearance

Figure 1-26 Appearance of the QSW-M7600-24SFP/12GT4XS-EB

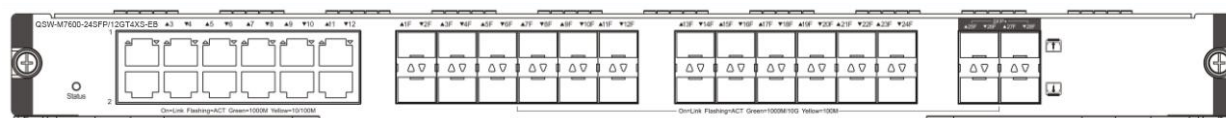

External Port

QSW-M7600-24SFP/12GT4XS-EB provides 12 10/100/1000BASE-T RJ45 ports, 24 SFP ports and 4 SFP+ ports. The first 12 SFP ports are combo ports. The RJ45 ports support 10/100/1000Mbps auto-negotiation. The SFP ports support hot swapping and the rate of 100/1000Mbps. And the SFP+ ports support 10G SFP+ modules, Gigabit SFP modules and hot swapping. The copper ports at 10/100Mbps do not support half-duplex mode.

- i** The QSW-M7600-24SFP/12GT4XS-EB supports 10G SFP+ and Gigabit SFP modules. 10G SFP+ modules cannot be used as Gigabit SFP modules.

LED

LED	Identification on the panel	Status	Meaning
System LED	Status	Off	The module is NOT receiving power.
		Solid red	The module is faulty.

		Blinking green	Initialization is in progress. Continuous blinking indicates errors.
		Solid green	The module is operational
GT port LED	Link/ACT	Off	The port link is NOT connected.
		Solid green	The port is connected at 1000Mbps.
		Solid yellow	The port is connected at 10Mbps or 100Mbps.
		Blinking	The port is transmitting and receiving data.
SFP port LED	Link/ACT	Off	The port link is NOT connected.
		Solid green	The port is connected at 1000Mbps.
		Solid yellow	The port is connected at 100Mbps.
		Blinking	The port is transmitting and receiving data.
SFP+ port LED	Link/ACT	Off	The port link is NOT connected.
		Solid green	The port is connected.
		Blinking	The port is transmitting and receiving data.

Specifications

Model	QSW-M7600-24SFP/12GT4XS-EB
CPU	Quad-core CPU, each core with the clock speed of 1.0G
BOOTROM	8 MB
Flash Memory	512 MB
SDRAM	DDRIII 1 GB
Port Type	12 10/100/1000BASE-T RJ45 ports, 24 SFP ports and 4 SFP+ ports
Transmission	10/100/1000BASE-T Cat-5 UTP

Medium	<p>100BASE-FX(1310nm) Multi-mode or single-mode optical fiber, supported by SFP ports while not supported by SFP+ ports.</p> <p>100BASE-FX (1550nm) Single-mode optical fiber, supported by SFP ports while not supported by SFP+ ports.</p> <p>1000BASE-SX (850nm) Multi-mode optical fiber</p> <p>1000BASE-LX (1310nm) Single-mode optical fiber</p> <p>1000BASE-LH (1310nm) Single-mode optical fiber</p> <p>1000BASE-ZX (1550nm) Single-mode optical fiber</p> <p>10GBASE-SR (850nm) Multi-mode optical fiber</p> <p>10GBASE-LR (1310nm) Single-mode optical fiber</p> <p>10GBASE-ER (1550nm) Single-mode optical fiber</p> <p>10GBASE-ZR (1550nm) Single-mode optical fiber</p>
LED	Status, Link/ACT
Hot Swapping	Supported
Power Consumption	<85W
EMC Standards	GB9254-2008 CLASS A
Safety Standards	GB4943-2011
Operating Temperature	0°C to 50°C
Storage Temperature	-40°C to 70°C
Operating Humidity	10% to 90% RH (non-condensing)
MTBF	335,000 hours
Weight	Net weight: 2.90 kg
Dimensions (W x D x H)	438.5 mm x 309.0 mm x 40.1 mm

1.4.5 QSW-M7600-36GT12SFP4XS-EB

Module Appearance

Figure 1-27 Appearance of the QSW-M7600-36GT12SFP4XS-EB

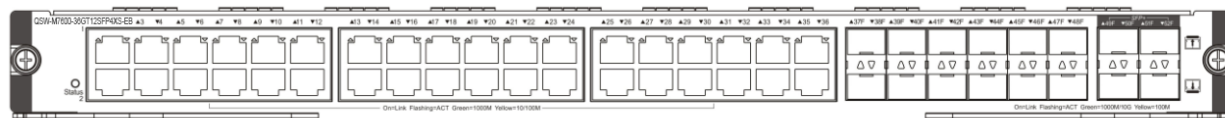

External Port

QSW-M7600-36GT12SFP4XS-EB provides 36 10/100/1000BASE-T RJ45 ports, 12 SFP ports and 4 SFP+ ports. The RJ45 ports support 10/100/1000Mbps auto-negotiation. The SFP ports support hot swapping and the rate of 100/1000Mbps. And the SFP+ ports support 10G SFP+ modules, Gigabit SFP modules and hot swapping. The copper ports at 10/100Mbps do not support half-duplex mode.

- i** The QSW-M7600-36GT12SFP4XS-EB supports 10G SFP+ and Gigabit SFP modules. 10G SFP+ modules cannot be used as Gigabit SFP modules.

LED

LED	Identification on the panel	Status	Meaning
System LED	Status	Off	The module is NOT receiving power.
		Solid red	The module is faulty.
		Blinking green	Initialization is in progress. Continuous blinking indicates errors.
		Solid green	The module is operational
GT port LED	Link/ACT	Off	The port link is NOT connected.
		Solid green	The port is connected at 1000Mbps.
		Solid yellow	The port is connected at 10Mbps or 100Mbps.
		Blinking	The port is transmitting and receiving data.
SFP port LED	Link/ACT	Off	The port link is NOT connected.
		Solid green	The port is connected at 1000Mbps.
		Solid yellow	The port is connected at 100Mbps.

		Blinking	The port is transmitting and receiving data.
SFP+ port LED	Link/ACT	Off	The port link is NOT connected.
		Solid green	The port is connected.
		Blinking	The port is transmitting and receiving data.

Specifications

Model	QSW-M7600-36GT12SFP4XS-EB		
CPU	Quad-core CPU, each core with the clock speed of 1.0G		
BOOTROM	8 MB		
Flash Memory	512 MB		
SDRAM	DDRIII 1 GB		
Port Type	36 10/100/1000BASE-T RJ45 ports, 12 SFP ports and 4 SFP+ ports		
Transmission Medium	10/100/1000BASE-T	Cat-5 UTP	
	100BASE-FX(1310nm)	Multi-mode or single-mode optical fiber, supported by SFP ports while not supported by SFP+ ports.	
	100BASE-FX (1550nm)	Single-mode optical fiber, supported by SFP ports while not supported by SFP+ ports.	
	1000BASE-SX (850nm)	Multi-mode optical fiber	
	1000BASE-LX (1310nm)	Single-mode optical fiber	
	1000BASE-LH (1310nm)	Single-mode optical fiber	
	1000BASE-ZX (1550nm)	Single-mode optical fiber	
	10GBASE-SR (850nm)	Multi-mode optical fiber	
	10GBASE-LR (1310nm)	Single-mode optical fiber	
	10GBASE-ER (1550nm)	Single-mode optical fiber	
	10GBASE-ZR (1550nm)	Single-mode optical fiber	
LED	Status, Link/ACT		
Hot Swapping	Supported		

Power Consumption	<80W
EMC Standards	GB9254-2008 CLASS A
Safety Standards	GB4943-2011
Operating Temperature	0°C to 50°C
Storage Temperature	-40°C to 70°C
Operating Humidity	10% to 90% RH (non-condensing)
MTBF	334,000 hours
Weight	Net weight: 2.90 kg
Dimensions (W x D x H)	438.5 mm x 309.0 mm x 40.1 mm

1.4.6 QSW-M7600-48GT4XS-EB

Module Appearance

Figure 1-28 Appearance of the QSW-M7600-48GT4XS-EB

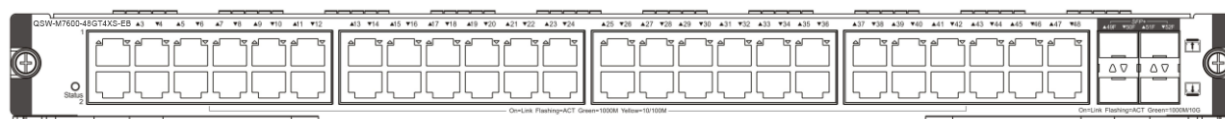

External Port

QSW-M7600-48GT4XS-EB provides 48 10/100/1000BASE-T RJ45 ports and 4 SFP+ ports. The RJ45 ports support 10/100/1000Mbps auto-negotiation. And the SFP+ ports support 10G SFP+ modules, Gigabit SFP modules and hot swapping. The copper ports at 10/100Mbps do not support half-duplex mode.

- i** The **QSW-M7600-48GT4XS-EB** supports 10G SFP+ and Gigabit SFP modules. 10G SFP+ modules cannot be used as Gigabit SFP modules.

LED

LED	Identification	Status	Meaning
-----	----------------	--------	---------

	on the panel		
System LED	Status	Off	The module is NOT receiving power.
		Solid red	The module is faulty.
		Blinking green	Initialization is in progress. Continuous blinking indicates errors.
		Solid green	The module is operational
GT port LED	Link/ACT	Off	The port link is NOT connected.
		Solid green	The port is connected at 1000Mbps.
		Solid yellow	The port is connected at 10Mbps or 100Mbps.
		Blinking	The port is transmitting and receiving data.
SFP+ port LED	Link/ACT	Off	The port link is NOT connected.
		Solid green	The port is connected.
		Blinking	The port is transmitting and receiving data.

Specifications

Model	QSW-M7600-48GT4XS-EB		
CPU	Quad-core CPU, each core with the clock speed of 1.0G		
BOOTROM	8 MB		
Flash Memory	512 MB		
SDRAM	DDRIII 1 GB		
Port Type	48 RJ45 ports and 4 SFP+ ports		
Transmission Medium	10/100/1000BASE-T	Cat-5 UTP	
	1000BASE-SX (850nm)		Multi-mode optical fiber
	1000BASE-LX (1310nm)		Single-mode optical fiber

	1000BASE-LH (1310nm) 1000BASE-ZX (1550nm) 10GBASE-SR (850nm) 10GBASE-LR (1310nm) 10GBASE-ER (1550nm) 10GBASE-ZR (1550nm)	Single-mode optical fiber Single-mode optical fiber Multi-mode optical fiber Single-mode optical fiber Single-mode optical fiber Single-mode optical fiber
LED	Status, Link/ACT	
Hot Swapping	Supported	
Power Consumption	<70W	
EMC Standards	GB9254-2008 CLASS A	
Safety Standards	GB4943-2011	
Operating Temperature	0°C to 50°C	
Storage Temperature	-40°C to 70°C	
Operating Humidity	10% to 90% RH (non-condensing)	
MTBF	329,000 hours	
Weight	Net weight: 2.80 kg	
Dimensions (W x D x H)	438.5 mm x 309.0 mm x 40.1 mm	

1.4.7 QSW-M7600-48SFP4XS-EB

Module Appearance

Figure 1-29 Appearance of the QSW-M7600-48SFP4XS-EB

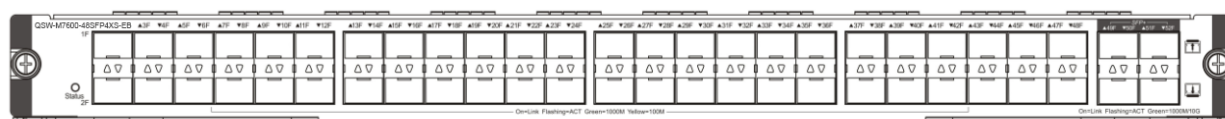

External Port

QSW-M7600-48SFP4XS-EB provides 48 SFP ports and 4 SFP+ ports. The SFP ports support 100/1000Mbps auto-negotiation and hot swapping. And the SFP+ ports support 10G SFP+ modules, Gigabit SFP modules and hot swapping. QSW-M7600-48SFP4XS-EB supports hot swapping.

 The **QSW-M7600-48SFP4XS-EB** supports 10G SFP+ and Gigabit SFP modules. 10G SFP+ modules cannot be used as Gigabit SFP modules.

LED

LED	Identification on the panel	Status	Meaning
System LED	Status	Off	The module is NOT receiving power.
		Solid red	The module is faulty.
		Blinking green	Initialization is in progress. Continuous blinking indicates errors.
		Solid green	The module is operational
SFP port LED	Link/ACT	Off	The port link is NOT connected.
		Solid green	The port is connected at 1000Mbps.
		Solid yellow	The port is connected at 10Mbps or 100Mbps.
		Blinking	The port is transmitting and receiving data.
SFP+ port LED	Link/ACT	Off	The port link is NOT connected.
		Solid green	The port is connected.
		Blinking	The port is transmitting and receiving data.

Specifications

Model	QSW-M7600-48SFP4XS-EB
CPU	Quad-core CPU, each core with the clock speed of 1.0G
BOOTROM	8 MB

Flash Memory	512 MB
SDRAM	DDRIII 1 GB
Port Type	48 10/100/1000BASE-T SFP ports and 4 SFP+ ports
Transmission Medium	<p>10/100/1000BASE-T Cat-5 UTP</p> <p>100BASE-FX(1310nm) Multi-mode or single-mode optical fiber, supported by SFP ports while not supported by SFP+ ports.</p> <p>100BASE-FX (1550nm) Single-mode optical fiber, supported by SFP ports while not supported by SFP+ ports.</p> <p>1000BASE-SX (850nm) Multi-mode optical fiber</p> <p>1000BASE-LX (1310nm) Single-mode optical fiber</p> <p>1000BASE-LH (1310nm) Single-mode optical fiber</p> <p>1000BASE-ZX (1550nm) Single-mode optical fiber</p> <p>10GBASE-SR (850nm) Multi-mode optical fiber</p> <p>10GBASE-LR (1310nm) Single-mode optical fiber</p> <p>10GBASE-ER (1550nm) Single-mode optical fiber</p> <p>10GBASE-ZR (1550nm) Single-mode optical fiber</p>
LED	Status, Link/ACT
Hot Swapping	Supported
Power Consumption	<101W
EMC Standards	GB9254-2008 CLASS A
Safety Standards	GB4943-2011
Operating Temperature	0°C to 50°C
Storage Temperature	-40°C to 70°C
Operating Humidity	10% to 90% RH (non-condensing)

MTBF	337,000 hours
Weight	Net weight: 2.80 kg
Dimensions (W x D x H)	438.5 mm x 309.0 mm x 40.1 mm

1.4.8 QSW-M7600-24GT24SFP4XS-EB

Module Appearance

Figure 1-30 Appearance of the QSW-M7600-24GT24SFP4XS-EB

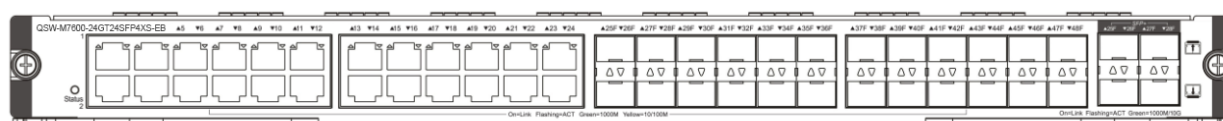

External Port

QSW-M7600-24GT24SFP4XS-EB provides 24 10/100/1000BASE-T RJ45 ports, 24 SFP ports and 4 SFP+ ports. The RJ45 ports support auto-negotiation at 10/100/1000 Mbps, The SFP ports support the rate of 100/1000M and hot swapping. The SFP+ ports support 10G SFP+ modules, Gigabit SFP modules and hot swapping. Copper ports do not support half-duplex at 10/100Mbps.

- i** The **QSW-M7600-24GT24SFP4XS-EB** supports 10G SFP+ and Gigabit SFP modules. 10G SFP+ modules cannot be used as Gigabit SFP modules.

LED

LED	Identification on the panel	Status	Meaning
System LED	Status	Off	The module is NOT receiving power.
		Solid red	The module is faulty.
		Blinking green	Initialization is in progress. Continuous blinking indicates errors.
		Solid green	The module is operational
GT port LED	Link/ACT	Off	The port link is NOT connected.
		Solid green	The port is connected at 1000Mbps.
		Solid yellow	The port is connected at 10/100Mbps.

		Blinking	The port is transmitting and receiving data.
SFP port LED	Link/ACT	Off	The port link is NOT connected.
		Solid green	The port is connected at 1000Mbps.
		Solid yellow	The port is connected at 10Mbps or 100Mbps.
		Blinking	The port is transmitting and receiving data.
SFP+ port LED	Link/ACT	Off	The port link is NOT connected.
		Solid green	The port is connected.
		Blinking	The port is transmitting and receiving data.

Specifications

Model	QSW-M7600-24GT24SFP4XS-EB		
CPU	Quad-core CPU, each core with the clock speed of 1.0G		
BOOTROM	8 MB		
Flash Memory	512 MB		
SDRAM	DDRIII 1 GB		
Port Type	24 10/100/1000BASE-T RJ45 ports, 24 SFP ports and 4 SFP+ ports		
Transmission Medium	10/100/1000BASE-T	Cat-5 UTP	
	100BASE-FX(1310nm)	Multi-mode or single-mode optical fiber, supported by SFP ports while not supported by SFP+ ports.	
	100BASE-FX (1550nm)	Single-mode optical fiber, supported by SFP ports while not supported by SFP+ ports.	
	1000BASE-SX (850nm)	Multi-mode optical fiber	
	1000BASE-LX (1310nm)	Single-mode optical fiber	
	1000BASE-LH (1310nm)	Single-mode optical fiber	
	1000BASE-ZX (1550nm)	Single-mode optical fiber	

	10GBASE-SR (850nm) 10GBASE-LR (1310nm) 10GBASE-ER (1550nm) 10GBASE-ZR (1550nm)	Multi-mode optical fiber Single-mode optical fiber Single-mode optical fiber Single-mode optical fiber
LED	Status, Link/ACT	
Hot Swapping	Supported	
Power Consumption	<88W	
EMC Standards	GB9254-2008 CLASS A	
Safety Standards	GB4943-2011	
Operating Temperature	0°C to 50°C	
Storage Temperature	-40°C to 70°C	
Operating Humidity	10% to 90% RH (non-condensing)	
MTBF	334,000 hours	
Weight	Net weight: 2.85 kg	
Dimensions (W x D x H)	438.5 mm x 309.0 mm x 40.1 mm	

1.4.9 QSW-M7600-32XS4QXS-DA

Module Appearance

Figure 1-31 Appearance of the QSW-M7600-32XS4QXS-DA

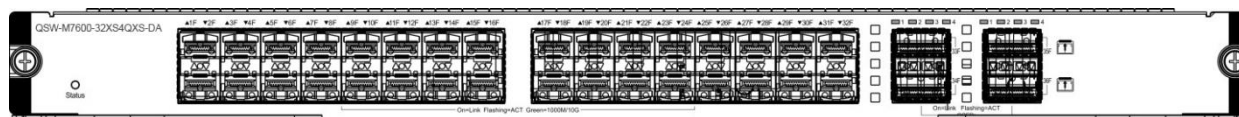

External Port

QSW-M7600-32XS4QXS-DA provides 32 SFP+ ports and 4 QSFP+ ports. The SFP+ ports support 10G SFP+ modules and Gigabit SFP modules. The QSFP+ ports support 40G QSFP+ modules. Hot swapping of QSW-M7600-32XS4QXS-DA, SFP, SFP+ and QSFP+ modules is supported.

i The **QSW-M7600-32XS4QXS-DA** supports 10G SFP+ and Gigabit SFP modules. 10G SFP+ modules cannot be used as Gigabit SFP modules.

LED

LED	Identification on the panel	Status	Meaning
System LED	Status	Off	The module is NOT receiving power.
		Solid red	The module is faulty.
		Blinking green	Initialization is in progress. Continuous blinking indicates errors.
		Solid green	The module is operational
SFP+ port LED	Link/ACT	Off	The port link is NOT connected.
		Solid green	The port is connected at 1000Mbps.
		Solid yellow	The port is connected at 10Mbps or 100Mbps.
		Blinking	The port is transmitting and receiving data.
QSFP+ port LED	Link/ACT	Off	The port link is NOT connected.
		Solid green	The port is connected.
		Blinking	The port is transmitting and receiving data.

Specifications

Model	QSW-M7600-32XS4QXS-DA
CPU	Quad-core CPU, each core with the clock speed of 1.5G
BOOTROM	16 MB

Flash Memory	8 MB	
SDRAM	DDR4 1 GB	
Port Type	32 10/100/1000BASE-T SFP+ ports, supporting 10G SFP+ modules and Gigabit SFP modules. 4 QSFP+ ports	
Transmission Medium	1000BASE-SX (850nm)	Multi-mode optical fiber
	1000BASE-LX (1310nm)	Single-mode optical fiber
	1000BASE-LH (1310nm)	Single-mode optical fiber
	1000BASE-ZX (1550nm)	Single-mode optical fiber
	10GBASE-SR (850nm)	Multi-mode optical fiber
	10GBASE-LR (1310nm)	Single-mode optical fiber
	10GBASE-ER (1550nm)	Single-mode optical fiber
	10GBASE-ZR (1550nm)	Single-mode optical fiber
	40GBASE-SR4	Multi-mode optical fiber
	40GBASE-LR4	Single-mode optical fiber
LED	Status, Link/ACT	
Hot Swapping	Supported	
Power Consumption	<210W	
EMC Standards	GB9254-2008 CLASS A	
Safety Standards	GB4943-2011	
Operating Temperature	0°C to 50°C	
Storage Temperature	-40°C to 70°C	
Operating Humidity	10% to 90% RH (non-condensing)	
MTBF	398,000 hours	

Weight	Net weight: 3.4 kg
Dimensions (W x D x H)	438.5 mm x 309.0 mm x 40.1 mm

1.4.10 QSW-M7600-24XT4QXS-DA

Module Appearance

Figure 1-32 Appearance of the QSW-M7600-24XT4QXS-DA

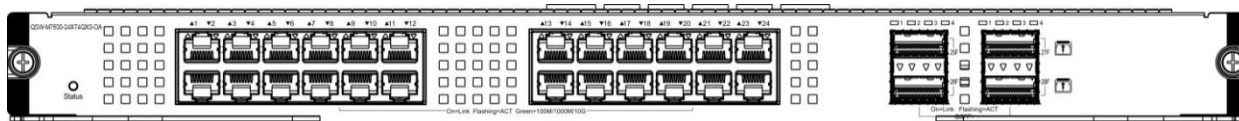

External Port

QSW-M7600-24XT4QXS -DA provides 24 10G RJ45 ports and 4 QSFP+ ports. The RJ45 ports support 100M/1G/10G auto-negotiation and full-duplex. The QSFP+ ports support 40G QSFP+ modules.

LED

LED	Identification on the panel	Status	Meaning
System LED	Status	Off	The module is NOT receiving power.
		Solid red	The module is faulty.
		Blinking green	Initialization is in progress. Continuous blinking indicates errors.
		Solid green	The module is operational
RJ45 port LED	Link/ACT	Off	The port is NOT connected.
		Solid green	The port is connected.
		Blinking	The port is transmitting and receiving data.
QSFP+ port LED	Link/ACT	Off	The port is NOT connected.
		Solid green	The port is connected.
		Blinking	The port is transmitting and receiving data.

Specifications

Model	QSW-M7600-24XT4QXS-DA
CPU	Quad-core CPU, each core with the clock speed of 1.5G
BOOTROM	16 MB
Flash Memory	8 MB
SDRAM	DDR4 1 GB
Port Type	32 10/100/1000BASE-T SFP+ ports, supporting 10G SFP+ modules and Gigabit SFP modules. 4 QSFP+ ports
Transmission Medium	100/1000BASE-T CAT-5 UTP Cable 10G BAST-T CAT-6
LED	Status, Link/ACT
Hot Swapping	Supported
Power Consumption	<245W
EMC Standards	GB9254-2008 CLASS A
Safety Standards	GB4943-2011
Operating Temperature	0°C to 50°C
Storage Temperature	-40°C to 70°C
Operating Humidity	10% to 90% RH (non-condensing)
MTBF	346,000 hours
Weight	Net weight: 3.7 kg

Dimensions (W x D x H)	438.5 mm x 309.0 mm x 40.1 mm
---------------------------	-------------------------------

1.4.11 QSW-M7610-FE-D I

Module Appearance

Figure 1-33 Appearance of the QSW-M7610-FE-D I

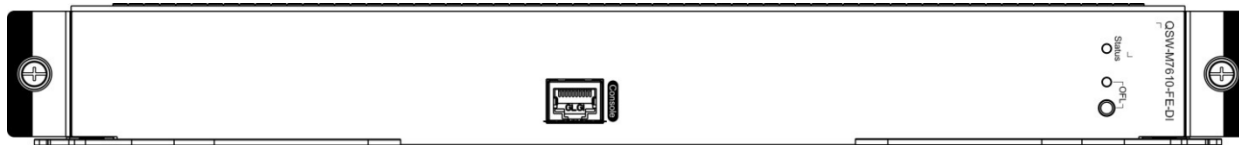

External Port

QSW-M7610-FE-D I provides one port.

- ❖ Console port: As a serial communications port, it uses the RS-232 interface level and standard RJ-45 connector.

Button

- ❖ Press the button for about five seconds and release the button. When the LED turns green, you can remove the FE card. Otherwise, packet loss may occur.

LED

LED	Identification on the panel	Status	Meaning
System LED	Status	Off	The module is NOT receiving power.
		Solid red	The module is faulty.
		Blinking green	Initialization is in progress. Continuous blinking indicates errors.
		Solid green	The module is operational
Offline LED	OFL	Off	Switching service is in progress. The module cannot be removed.
		Solid green	Release the Offline button and wait for 2s before removing the module.

Specifications

Model	QSW-M7610-FE-D I
-------	------------------

CPU	Quad-core CPU, each core with the clock speed of 1.5G
BOOTROM	16 MB
Flash Memory	8 MB
SDRAM	DDR4 1 GB
Port Type	1 console port
LED	Status
Hot Swapping	Supported
Power Consumption	<50W
EMC Standards	GB9254-2008 CLASS A
Safety Standards	GB4943-2011
Operating Temperature	0°C to 50°C
Storage Temperature	-40°C to 70°C
Operating Humidity	10% to 90% RH (non-condensing)
MTBF	460,000 hours
Weight	Net weight: 1.9 kg
Dimensions (W x D x H)	371.0 mm x 248.0 mm x 43.0 mm

1.4.12 QSW-PA1600I-F

Module Appearance

Figure 1-34 Appearance of the QSW-PA1600I-F Module

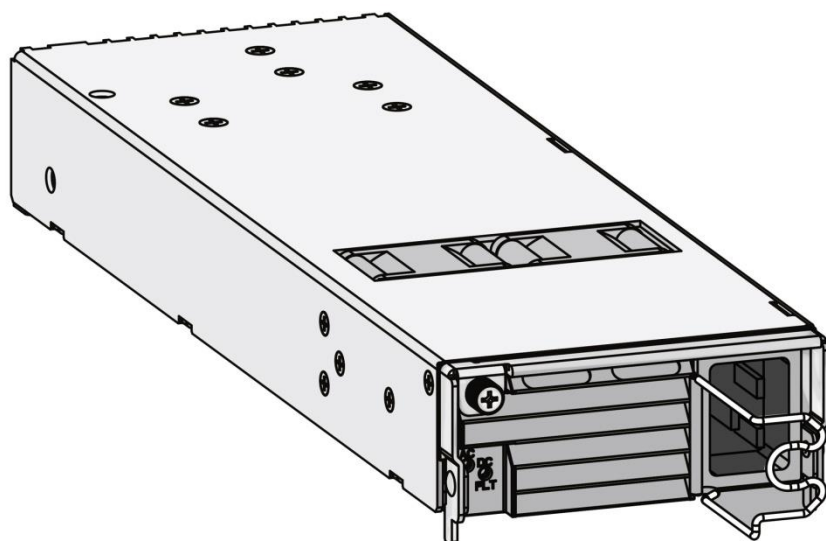

External port

The QSW-PA1600I-F module provides 12 VAC input to the overall system of the QSW-7608 switch. The front panel of the power supply module provides a 3-pin power port, which can be connected to standard 16A power cord.

LED

LED		Meaning
AC	DC/FLT	
Solid green	Solid green	The module is operational
Off	Solid red	There is no power input or input undervoltage.
Solid green	Solid red	Overvoltage.
Solid green	Solid red	Overcurrent.
Solid green	Solid orange	Temperature alarm
Solid green	Solid red	Over-temperature fault
Solid green	Solid red	PSR on/off

Specifications

Module Model	QSW-PA1600I-F
Rated Voltage Range	100 to 120 VAC, 200 to 240 VAC; 50/60 Hz
Max Voltage Range	90 to 264 VAC; 47 to 63 Hz
Max Power Output	90 to 180 VAC Power: 1200 W 180 to 264 VAC Power: 1600 W
High Current DC Parameter	192 to 290VDC Power: 1600W
Weight	Net weight: 2.04 kg
Power Cord Requirement	16A power cord

i When you plug the power cable into the power supply, pull down the retention clip over the plug on the power cable.

Operation Altitude: 5000m max. Storage Altitude: 5000 max.

1.4.13 QSW-PA600I-F

Module Appearance

Figure 1-35 Appearance of the QSW-PA600I-F Module

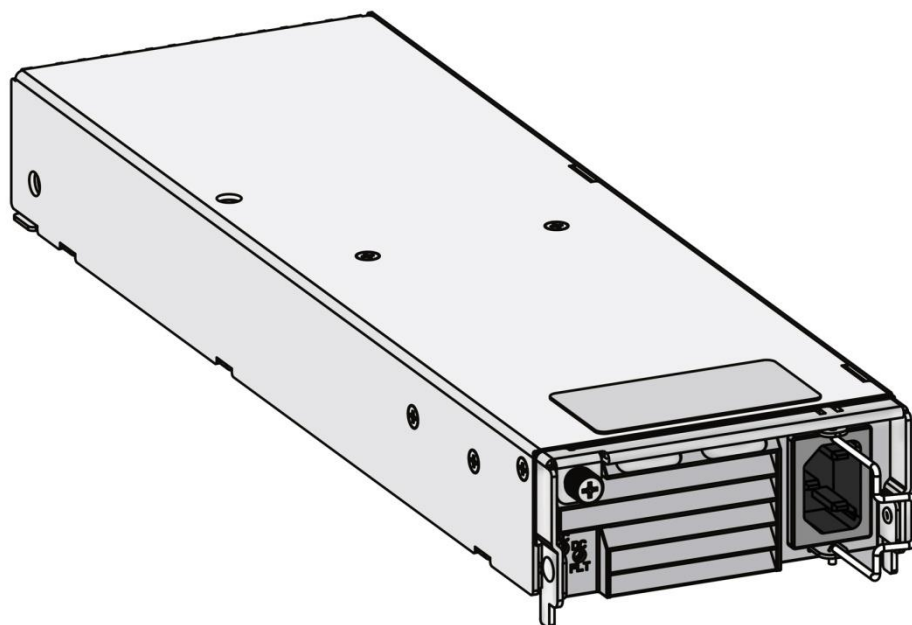

External Port

The QSW-PA600I-F module provides 12 VAC input to the overall system of the QSW-7608 switch. The front panel of the power supply module provides a 3-pin power port, which can be connected to standard 10A power cord.

LED

LED		Meaning
AC	DC/FLT	
Solid green	Solid green	The module is operational
Off	Solid red	There is no power input or input undervoltage.
Solid green	Solid red	Overvoltage
Solid green	Solid red	Overcurrent
Solid green	Solid orange	Temperature alarm
Solid green	Solid red	Over-temperature fault
Solid green	Solid red	PSR on/off

Specifications

Module	QSW-PA600I-F
--------	--------------

Model	
Rated Voltage Range	100 to 120 VAC, 200 to 240 VAC; 50/60 Hz
Max Voltage Range	90 to 264 VAC; 47 to 63 Hz
Max Power Output	90 to 180 VAC Power: 600 W 180 to 264 VAC Power: 600 W
High Current DC Parameter	192 to 290VDC Power: 600 W
Weight	Net weight: 1.64 kg
Power Cord Requirement	10A power cord

i When you plug the power cable into the power supply, pull down the retention clip over the plug on the power cable. Operation Altitude: 5000m max. Storage Altitude: 5000 max.

1.4.14 QSW-PD600I-F

Module Appearance

Figure 1-36 Appearance of the QSW-PD600I-F Module

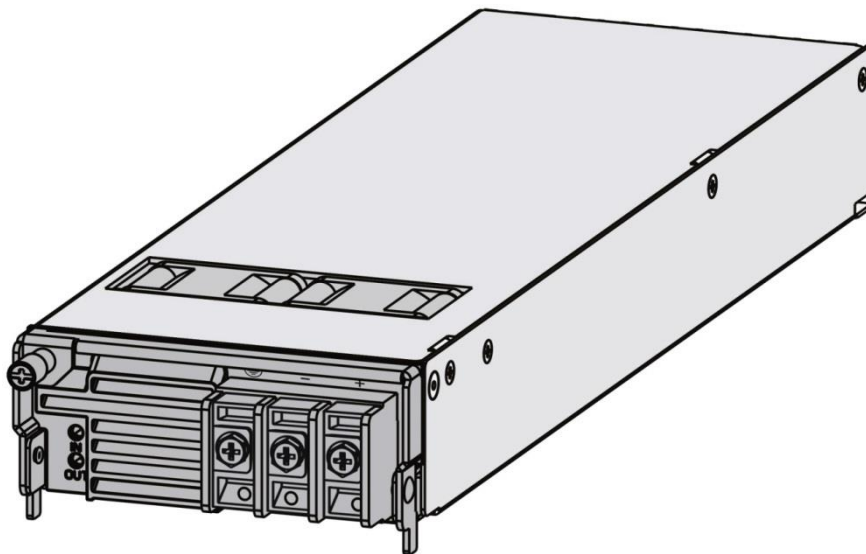

External Port

The QSW-PD600I module provides one DC (-48V) power port.

LED

LED		Meaning
AC	DC/FLT	
Solid green	Solid green	The module is operational
Solid green	Solid red	There is external power supply. The power module is not in use.
Off	Solid red	There is no external power supply. The power module is in use.
Off	Solid red	Overcurrent
Solid green	Solid red	Output overcurrent protection
Solid green	Solid orange	Temperature alarm
Solid green	Solid red	Over-temperature protection
Solid green	Solid red	PSR on/off
Solid green	Solid red	Phase loss protection
Solid green	Solid red	Fan failure

Specifications

Module Model	QSW-PD600I-F
Rated Voltage Range	-48VDC
Max Voltage Range	-40VDC to -75VDC
Max Power Output	600W
Weight	Net weight: 1.30 kg
Power Cord Requirement	20A power cord

i When you plug the power cable into the power supply, pull down the retention clip over the plug on the power cable. Operation Altitude: 2000m max. Storage Altitude: 2000 max.

1.4.15 QSW-PA300I-F

Module Appearance

Figure 1-37 Appearance of the QSW-PA300I-F Module

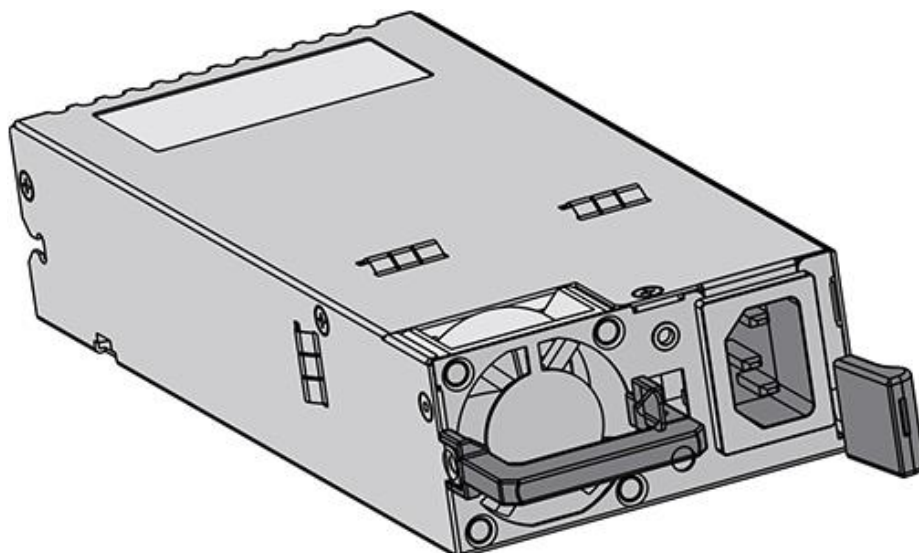

External Port

The QSW-PA300I-F module provides 12 VAC input to the overall system of the QSW-7605 switch. The front panel of the power supply module provides a 3-pin power port, which can be connected to standard 10A power cord.

LED

LED	Indicator	Status	Meaning
Status LED	N/A	Off	A power fault occurs or there is no power input
		Solid green	The module is operational

Specifications

Module Model	QSW-PA300I-F
Rated Voltage Range	100 to 120 VAC, 200 to 240 VAC; 50/60 Hz

Max Voltage Range	90 to 264 VAC; 47 to 63 Hz
Max Power Output	90 to 180 VAC Power: 300 W 180 to 264 VAC Power: 300 W
Weight	Net weight: 0.85 kg
Power Cord Requirement	10A power cord

! When you plug the power cable into the power supply, pull down the retention clip over the plug on the power cable.

i Operation Altitude: 5000m max. Storage Altitude: 5000 max.

1.4.16 QSW-PA1600I

Module Appearance

Figure 1-38 Appearance of the QSW-PA1600I Module

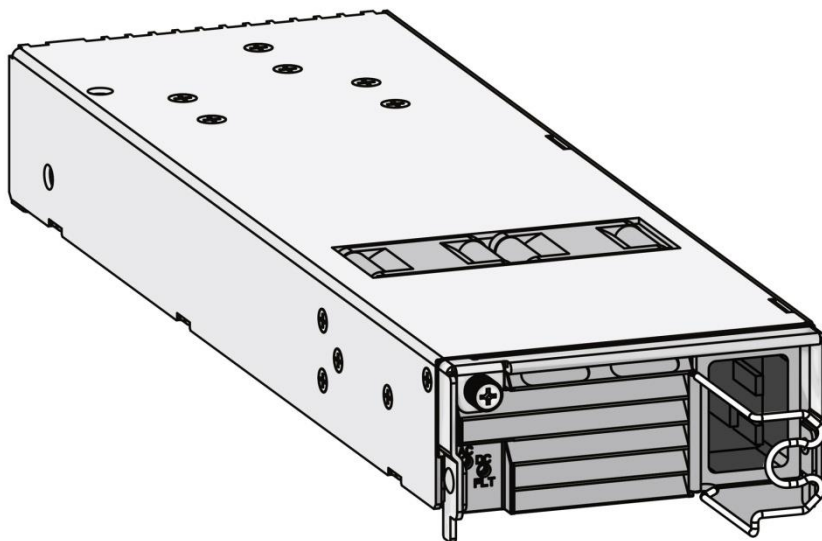

External Port

The QSW-PA1600I module provides 12 VAC input to the overall system of the QSW-7610 switch. The front panel of the power supply module provides a 3-pin power port, which can be connected to standard 16A power cord.



LED

LED		Meaning
AC	DC/FLT	

Solid green	Solid green	The module is operational
Off	Solid red	There is no power input or input undervoltage.
Solid green	Solid red	Overvoltage.
Solid green	Solid red	Overcurrent.
Solid green	Solid orange	Temperature alarm
Solid green	Solid red	Over-temperature fault
Solid green	Solid red	PSR on/off

Specifications

Module Model	QSW-PA1600I
Rated Voltage Range	100 to 120 VAC, 200 to 240 VAC; 50/60 Hz
Max Voltage Range	90 to 264 VAC; 47 to 63 Hz
Max Power Output	90 to 180 VAC Power: 1200 W 180 to 264 VAC Power: 1600 W
HVDC	192 to 216 VDC Power: 1200W 216 to 290 VDC Power: 1600W
Weight	Net weight: 2.04 kg
Power Cord Requirement	16A power cord

-  When you plug the power cable into the power supply, pull down the retention clip over the plug on the power cable.
-  Operation Altitude: 4000m max. Storage Altitude: 4000 max.

1.4.17 QSW-PA600I

Module Appearance

Figure 1-39 Appearance of the QSW-PA600I Module

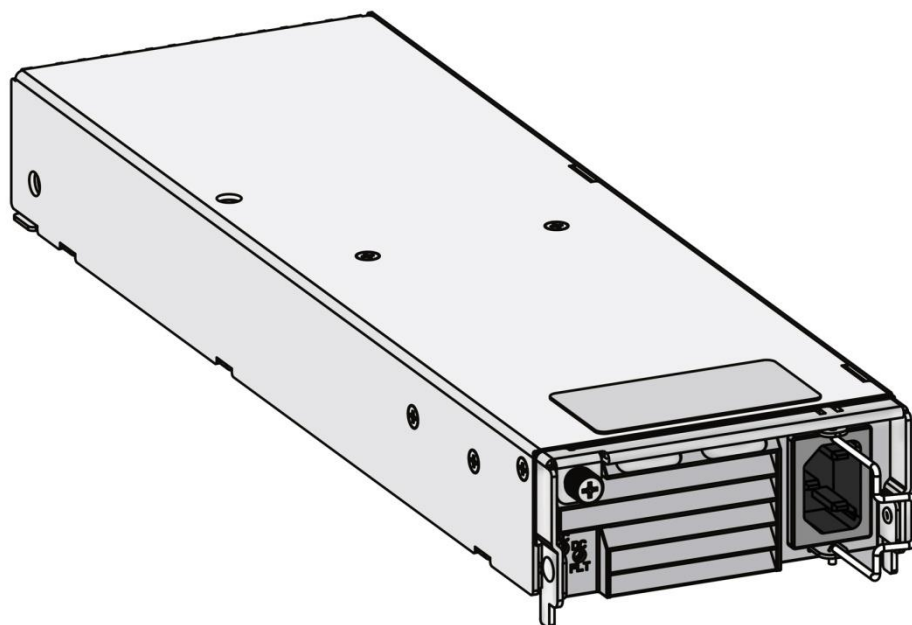

External Port

The QSW-PA600I module provides 12 VAC input to the overall system of the QSW-7610 switch. The front panel of the power supply module provides a 3-pin power port, which can be connected to standard 10A power cord.

LED

LED		Meaning
AC	DC/FLT	
Solid green	Solid green	The module is operational
Off	Solid red	There is no power input or input undervoltage.
Solid green	Solid red	Overvoltage.
Solid green	Solid red	Overcurrent.
Solid green	Solid orange	Temperature alarm
Solid green	Solid red	Over-temperature fault
Solid green	Solid red	PSR on/off

Specifications

Module Model	QSW-PA1600I
--------------	-------------

Rated Voltage Range	100 to 120 VAC, 200 to 240 VAC; 50/60 Hz
Max Voltage Range	90 to 264 VAC; 47 to 63 Hz
Max Power Output	90 to 180 VAC Power: 600 W 180 to 264 VAC Power: 600 W
HVDC	192 to 290 VDC Power: 600W
Weight	Net weight: 1.64 kg
Power Cord Requirement	10A power cord

- i When you plug the power cable into the power supply, pull down the retention clip over the plug on the power cable.
- i Operation Altitude: 4000m max. Storage Altitude: 4000 max.

1.4.18 QSW-PD1600I

Module Appearance

Figure 1-40 Appearance of the QSW-PD1600I Module

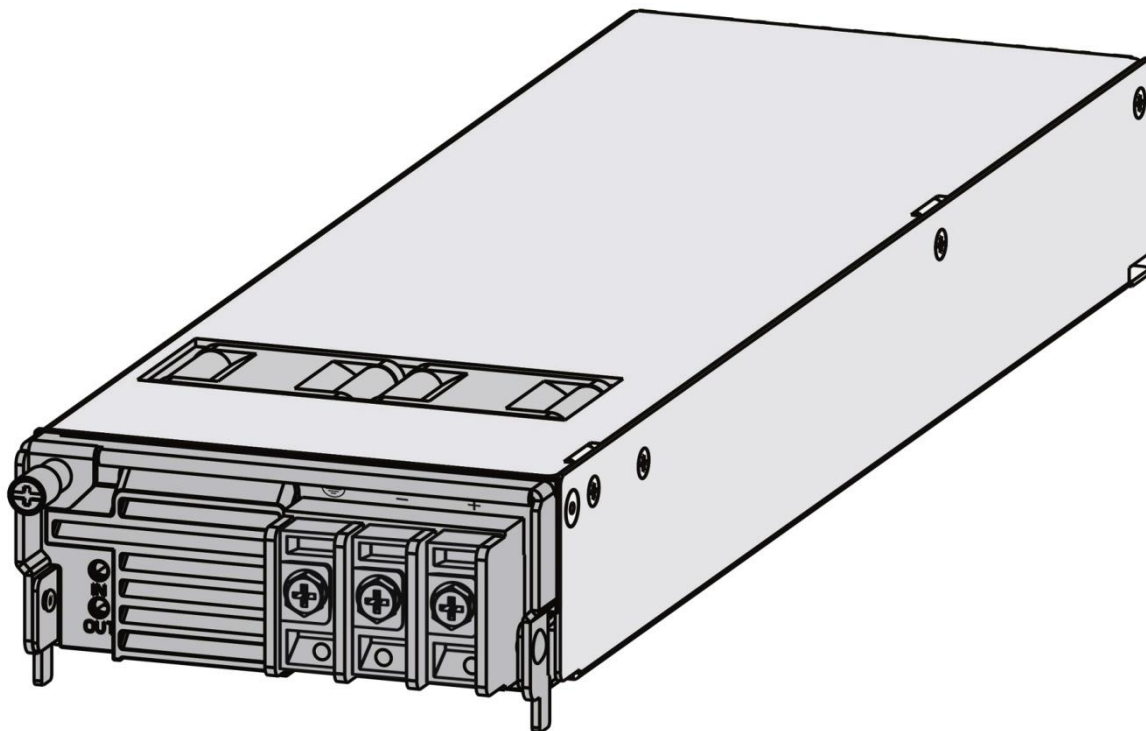

External Port

The QSW-PD1600I module provides one DC (-48V) power port.

LED

LED		Meaning
AC	DC/FLT	
Solid green	Solid green	The module is operational
Solid green	Solid red	There is external power supply. The power module is not in use.
Off	Solid red	There is no external power supply. The power module is in use.
Off	Solid red	Overcurrent
Solid green	Solid red	Output overcurrent protection
Solid green	Solid orange	Temperature alarm
Solid green	Solid red	Over-temperature protection
Solid green	Solid red	PSR on/off
Solid green	Solid red	Phase loss protection
Solid green	Solid red	Fan failure

Specifications

Module Model	QSW-PD600I
Rated Voltage Range	-48VDC
Max Voltage Range	-40VDC to -75VDC
Max Power Output	1400W
Weight	Net weight: 1.60 kg

Power Cord Requirement	50A power cord
------------------------	----------------

i When you plug the power cable into the power supply, pull down the retention clip over the plug on the power cable.

i Operation Altitude: 2000m max. Storage Altitude: 2000 max.

1.4.19 QSW-PD600I

Module Appearance

Figure 1-41 Appearance of the QSW-PD600I Module

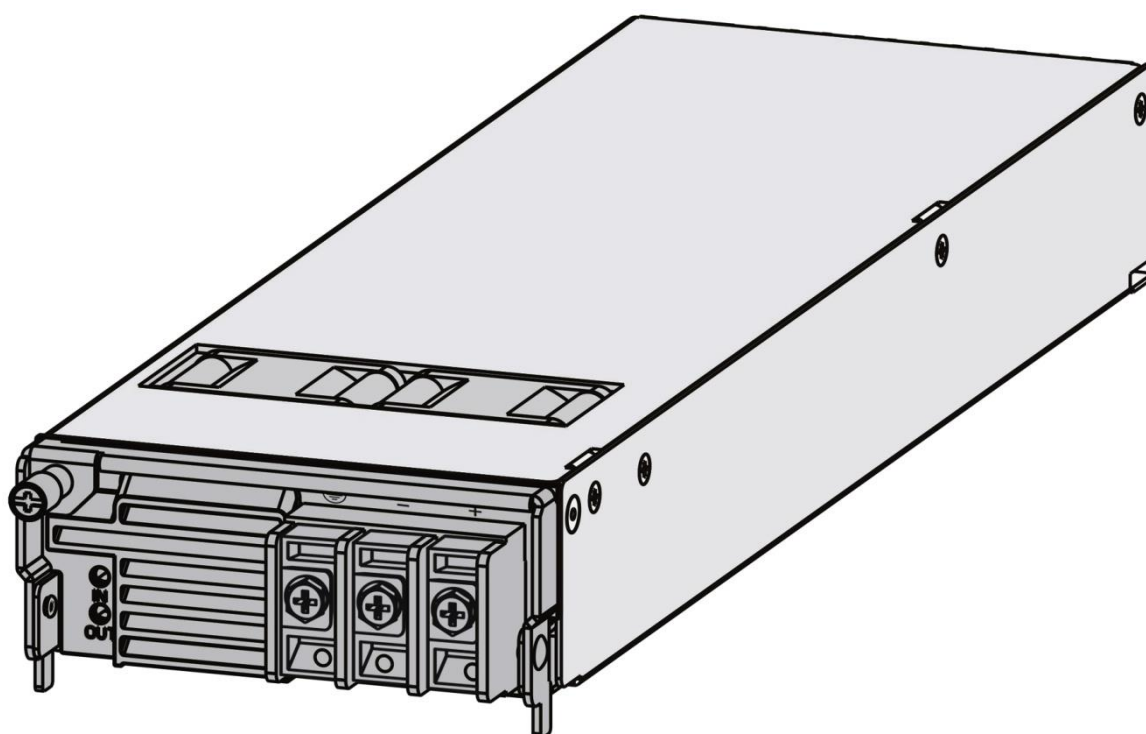

External Port

The QSW-PD600I module provides one DC (-48V) power port.

LED

LED		Meaning
AC	DC/FLT	
Solid green	Solid green	The module is operational
Solid green	Solid red	There is external power supply. The power module is not in use.

Off	Solid red	There is no external power supply. The power module is in use.
Off	Solid red	Overcurrent
Solid green	Solid red	Output overcurrent protection
Solid green	Solid orange	Temperature alarm
Solid green	Solid red	Over-temperature protection
Solid green	Solid red	PSR on/off
Solid green	Solid red	Phase loss protection
Solid green	Solid red	Fan failure

Specifications

Module Model	QSW-PD600I
Rated Voltage Range	-48VDC
Max Voltage Range	-40VDC to -75VDC
Max Power Output	600W
Weight	Net weight: 1.30 kg
Power Cord Requirement	20A power cord

i When you plug the power cable into the power supply, pull down the retention clip over the plug on the power cable.

i Operation Altitude: 2000m max. Storage Altitude: 2000 max.

1.4.20 QSW-M76-PSE

Figure 1-42 Appearance of the QSW-M76-PSE Module

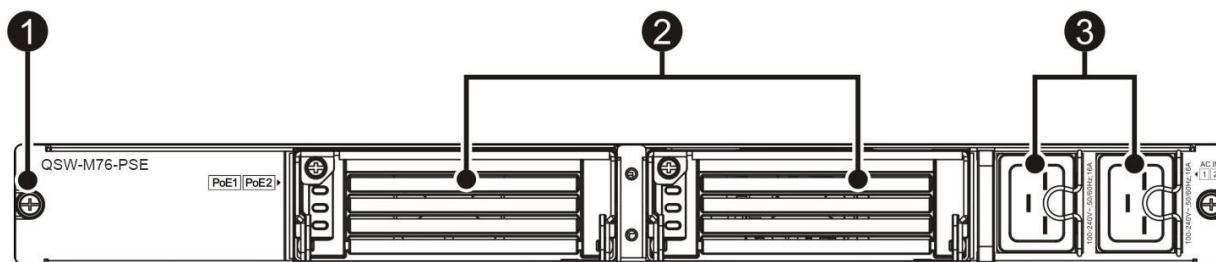

Note:	1. Captive screw of the PSE module 2. PoE power slots	3. Jacks for PoE cables
-------	--	-------------------------

Composition

The QSW-M76-PSE module provides PoE power input to QSW-7608. The front panel of the power supply module provides two PoE power supply slots and two 3-pin power port, which can be connected to standard 16A power cord. The QSW-M76-PSE module supports QSW-PA3000I-PL and QSW-PA1600I-PL power supply module.

- ⚠ Do not insert the PoE power supply into the system power module slot.
- ⚠ Do not connect the PoE power cord to the system power supply. The 3-pin power port for the PoE module is on the QSW-M76-PSE module.
- ⚠ The QSW-M76-PSE module provides two PoE power module slots (PoE1 and PoE2) and two 3-pin power ports (port for PoE1 is the left one of ③ marked on Figure 1-15; port for PoE2 is the right one of ③ marked on Figure 1-15).

Specifications

Dimensions (W x D x H)	400mm x 439mm x 43mm
Weight	Net weight: 3.50 kg

1.4.21 QSW-PA3000I-PL

Module Appearance

Figure 1-44 Appearance of the QSW-PA3000I-PL Module

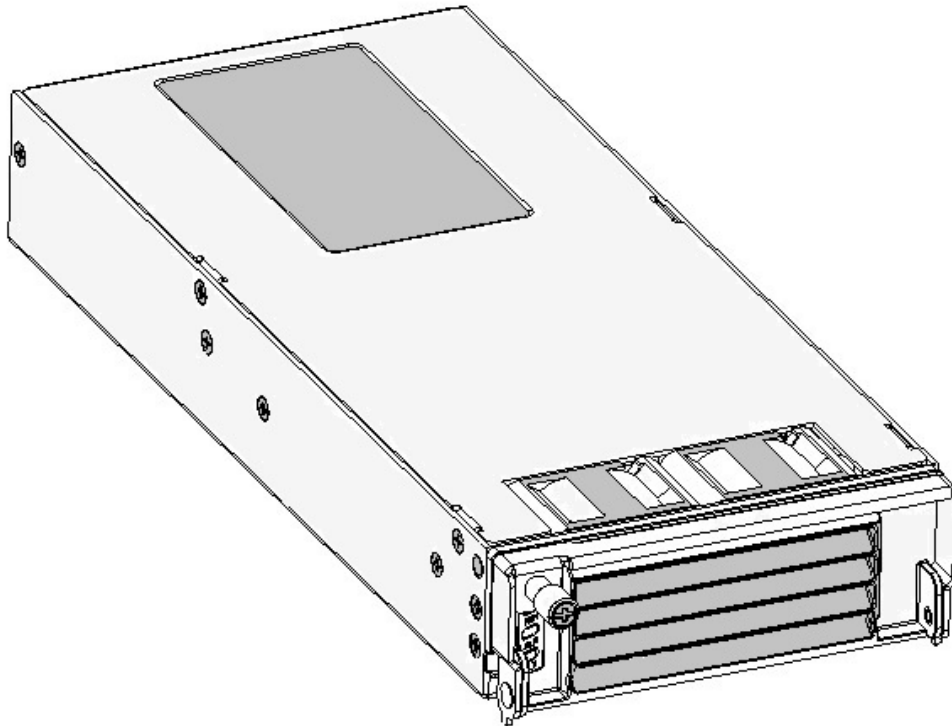

As an AC power module, the QSW-PA3000I-PL module provides PoE power input to the QSW-M76-PSE module.

External Port

The 3-pin power port for the PoE module is on the QSW-M76-PSE module. This port can be connected to standard 16 A power cord.

LED

LED			Meaning
Run	Alarm	Fault	
Solid green	Off	Off	The module is operational
Off	Off	Off	There is no power input
Blinking green	Off	Off	The module is in standby mode
Solid green	Solid yellow	Off	Persistent overcurrent.
Solid green	Solid yellow	Off	Temperature alarm
Off	Off	Solid red	Over-temperature causes power-off

Off	Off	Solid red	AC is powered off.
Off	Off	Solid red	Short circuit.
Off	Off	Solid red	Output undervoltage
Off	Off	Solid red	Output overvoltage
Solid green	Off	Blinking red	Communication fails

Specifications

Module Model	QSW-PA3000I-PL
Rated Voltage Range	100 to 120 VAC, 210 to 240 VAC; 50/60 Hz
Max Voltage Range	90 to 264 VAC; 47 to 63 Hz
Max Power Output	90 to 176 VAC Power: 1200 W 176 to 210 VAC Power: 2500 W 210 to 264 VAC Power: 3000W
Weight	Net weight: 2.10 kg
Power Cord Requirement	16A power cord

 Operation Altitude: 5000m max. Storage Altitude: 5000 max.

1.4.22 QSW-PA1600I-PL

Module Appearance

Figure 1-45 Appearance of the QSW-PA1600I-PL Module

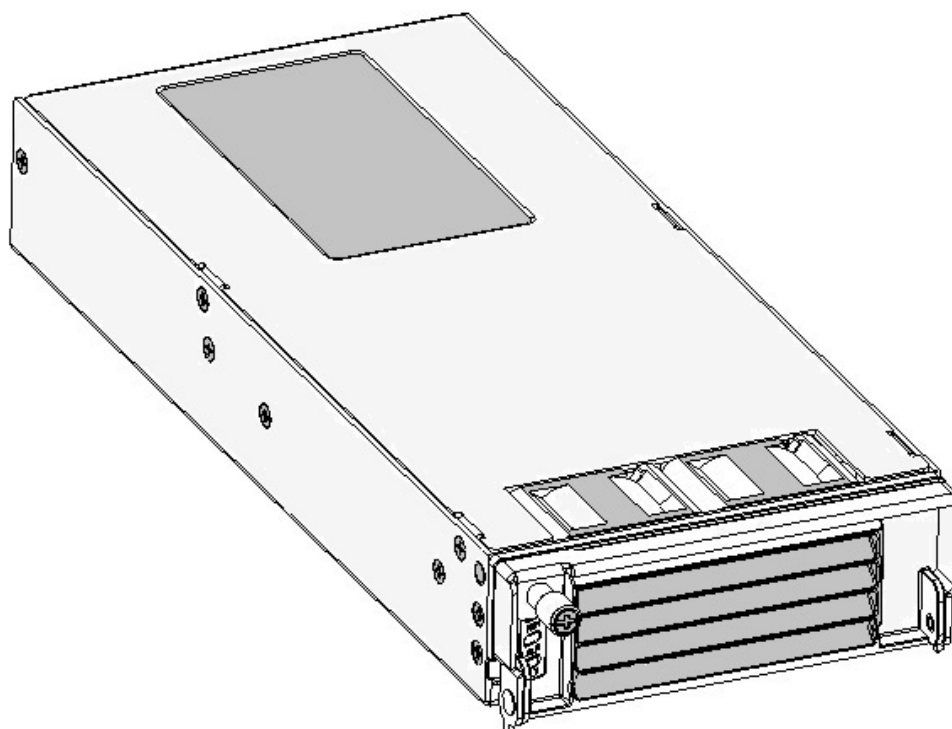

As an AC power module, the QSW-PA1600I-PL module provides PoE power input to the QSW-M76-PSE module.

External Port

The 3-pin power port for the PoE module is on the QSW-M76-PSE module. This port can be connected to standard 16 A power cord. For more information about QSW-M76-PSE, please refer to *QSW-M76-PSE*.

LED

LED			Meaning
Run	Alarm	Fault	
Solid green	Off	Off	The module is operational
Off	Off	Off	There is no power input
Blinking green	Off	Off	The module is in standby mode
Solid green	Solid yellow	Off	Persistent overcurrent.
Solid green	Solid yellow	Off	Temperature alarm
Off	Off	Solid red	Over-temperature causes

			power-off
Off	Off	Solid red	AC is powered off.
Off	Off	Solid red	Short circuit.
Off	Off	Solid red	Output undervoltage
Off	Off	Solid red	Output overvoltage
Solid green	Off	Blinking red	Communication fails

Specifications

Module Model	QSW-PA1600I-PL
Rated Voltage Range	100 to 120 VAC, 210 to 240 VAC; 50/60 Hz
Max Voltage Range	90 to 264 VAC; 47 to 63 Hz
Max Power Output	90 to 176 VAC Power: 1000 W 176 to 264 VAC Power: 1600 W
Weight	Net weight: 1.70 kg
Power Cord Requirement	16A power cord

 Operation Altitude: 5000m max. Storage Altitude: 5000 max.

1.4.23 QSW-M08-FAN

Module Appearance

Figure 1-47 Appearance of the QSW-M08-FAN Module

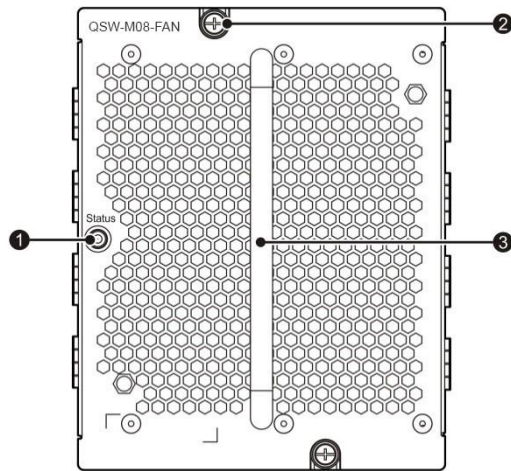

Note:	1. Fan status LED 2. Captive screws of fan tray	3. Fan handle
-------	--	---------------

Composition

The QSW-M08-FAN is the fan for service modules and supervisor modules on the QSW-7608. There is one QSW-M08-FAN tray with two fans and one fan control board. The QSW-M08-FAN draws air out to form convection for heat dissipation.

Specifications

Fan Model	QSW-M08-FAN
Dimension (W x D x H)	167.5 mm x 132 mm x 133 mm

LED

LED	Status	Meaning
Status	Off	The fan is NOT receiving power or fails.
	Solid green	The fan is operational.

Features

Function	Meaning
Status Monitoring	Rotational speed monitoring, failure alarm
Automatic	Speed-adjustment controlled by temperature

Speed-adjustment	
Hot Swapping	Hot swapping is supported by the fan tray.

1.4.24 QSW-M05-FAN

Module Appearance

Figure 1-48 Appearance of the QSW-M05-FAN Module

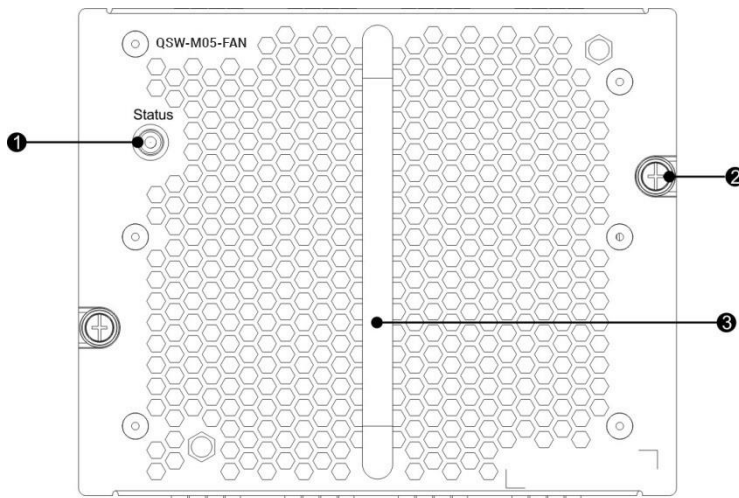

Note:	1. Fan status LED 2. Captive screws of fan tray	3. Fan handle
-------	--	---------------

Composition

The QSW-M05-FAN is the fan for service modules and supervisor modules on the QSW-7605. There is one QSW-M08-FAN tray with two fans and one fan control board. The QSW-M05-FAN draws air out to form convection for heat dissipation.

Specifications

Fan Model	QSW-M08-FAN
Dimension (W x D x H)	167.5 mm x 132 mm x 133 mm

LED

LED	Status	Meaning
Status	Off	The fan is NOT receiving power or fails.

	Solid green	The fan is operational.
--	-------------	-------------------------

Features

Function	Meaning
Status Monitoring	Rotational speed monitoring, failure alarm
Automatic Speed-adjustment	Speed-adjustment controlled by temperature
Hot Swapping	Hot swapping is supported by the fan tray.

1.4.25 QSW-M10-FAN

Module Appearance

Figure 1-49 Appearance of the QSW-M10-FAN Module

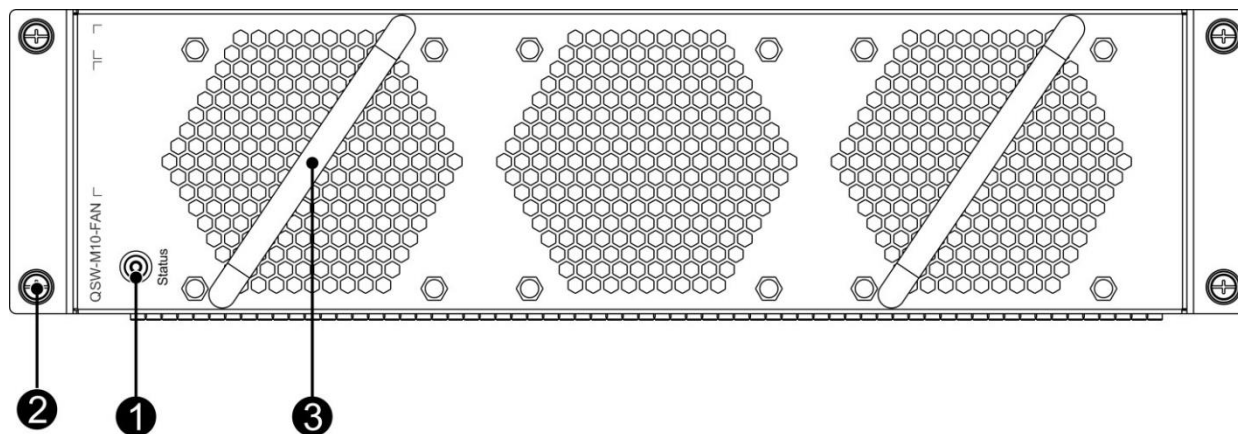

Note:	1. Fan status LED 2. Captive screws of fan tray	3. Fan handle
-------	--	---------------

Composition

The QSW-M10-FAN is the fan for service modules and supervisor modules on the QSW-7610. There is one QSW-M10-FAN tray with six fans and one fan control board. The QSW-M10-FAN draws air out to form convection for heat dissipation.

Specifications

Fan Model	QSW-M10-FAN
-----------	-------------

Dimension (W x D x H)	91 mm x 94 mm x 370 mm
--------------------------	------------------------

LED



LED	Status	Meaning
Status	Off	The fan is NOT receiving power or fails.
	Solid green	The fan is operational.
	Red	A fan fails.

Features

Function	Meaning
Status Monitoring	Rotational speed monitoring, failure alarm
Automatic Speed-adjustment	Speed-adjustment controlled by temperature
Hot Swapping	Hot swapping is supported by the fan tray.

2 PREPARATION BEFORE INSTALLATION

2.1 Safety Suggestions

-
-  To avoid body injury and equipment damage, please carefully read the safety suggestions before you install QSW-7600.
 -  The following safety suggestions do not cover all possible dangers.
-

2.1.1 General Suggestions

- ❖ Take security measures (such as wearing an anti-static wrist strap) to ensure safety.
- ❖ Keep the chassis clean, free from any dust. Please do not place the switch at a damp place to prevent the moisture from entering the switch.
- ❖ Make sure the installation site is dry and flat. Take skid-proof measures.
- ❖ Do not place the equipment in a walking area.
- ❖ Do not wear loose clothes or any other things that may be caught by the chassis during installation and maintenance.
- ❖ Moving or lifting the switch and its components requires team work. Be careful not to get hurt.

2.1.2 Safety Precautions for Removal

QSW-7600 is large and heavy. When you handle them, please pay attention to the following requirements:

- ❖ Avoid moving the equipment frequently.
- ❖ Turn off all power supplies and unplug all power cables before you remove the equipment.
- ❖ At least four people are needed to move the equipment. Do not attempt to move the equipment by one person only.
- ❖ Keep balance when moving the equipment, and avoid injuring your leg and feet or spraining your waist.

 Do not move the equipment by grasping the panel, power supply handle, ventilation holes of the chassis, as they are not designed to bear the weight of the entire equipment. This may cause damage or even injure you.

 Remove all supervisor modules, service modules and power modules before you move the device, to reduce the chassis weight.

 The device must be installed and used in the restricted access location.

2.1.3 Electrical Safety

- ❖ Please observe local regulations and specifications when performing electrical operations. Relevant operators must be qualified.
- ❖ Please carefully check for any potential danger in the working area, for example, ungrounded power supply, unreliable grounding of the power supply and damp/wet ground or floor.

- ❖ Find out the location of the emergency power supply switch in the room before installation. First cut off the power supply in case of an accident.
 - ❖ Be sure to make a careful check before you shut down the power supply.
 - ❖ Do not place the equipment in a damp/wet location. Do not let any liquid enter the chassis
-
- ⚠ Any nonstandard and inaccurate electrical operation can cause an accident such as fire or electrical attack, thus causing severe even fatal damages to human bodies and equipment.
 - ⚠ Direct or indirect touch through a wet object on high-voltage and mains supply can bring a fatal danger.
-

2.1.4 Static Discharge Damage Prevention

Although much has been done in QSW-7600 to prevent static electricity, great damage may be caused to the circuitry and equipment when the static electricity exceeds a certain limit. In the communication network of the QSW-7600, electrostatic induction may come from the following sources: External electric field produced by the high-voltage supply cable, lightning, etc; internal systems such as the indoor floor and the entire structure.

To prevent damage from static electricity, you must pay attention to the following:

- ❖ Properly ground the equipment.
- ❖ Take dust prevention measures in the room.
- ❖ Maintain an appropriate humidity.
- ❖ Always wear an anti-static wrist strap when you touch any circuit board.
- ❖ Try to hold a circuit board by its edges. Do not touch any components or the PCB.
- ❖ Use an anti-static shielding bag to properly store the board.
- ❖ Do not let any clothes touch a circuit board. An antistatic wrist strap can only prevent human static electricity from damaging the circuit board, but cannot prevent any static electricity on clothes.

-
- ⚠ The QSW-7600 series switches are equipped with an anti-static wrist strap. Please refer to Figure 2-1 for the position of the jack for the wrist strap.
-

The S7800C series switches are equipped with an anti-static wrist strap. To protect electronic components against static electricity, wear an anti-static wrist strap close to your skin and keep it properly grounded while installing swappable modules.

Use an anti-static wrist strap as follows:

1. Ensure that the switch is properly grounded.
2. Put your hand in the anti-static wrist strap.
3. Tighten the buckle till the trap is closely attached to your skin.

-
- ⚠ For safety, use a multimeter to measure the resistance between yourself and the ground, which should be within the range from 1 to 10 Ω .
 - ⚠ Make sure that the switch is properly grounded when the anti-static wrist strap is connected to the ground through the chassis jack.
-

Figure 2-1 Preventing EMI on QSW-7608

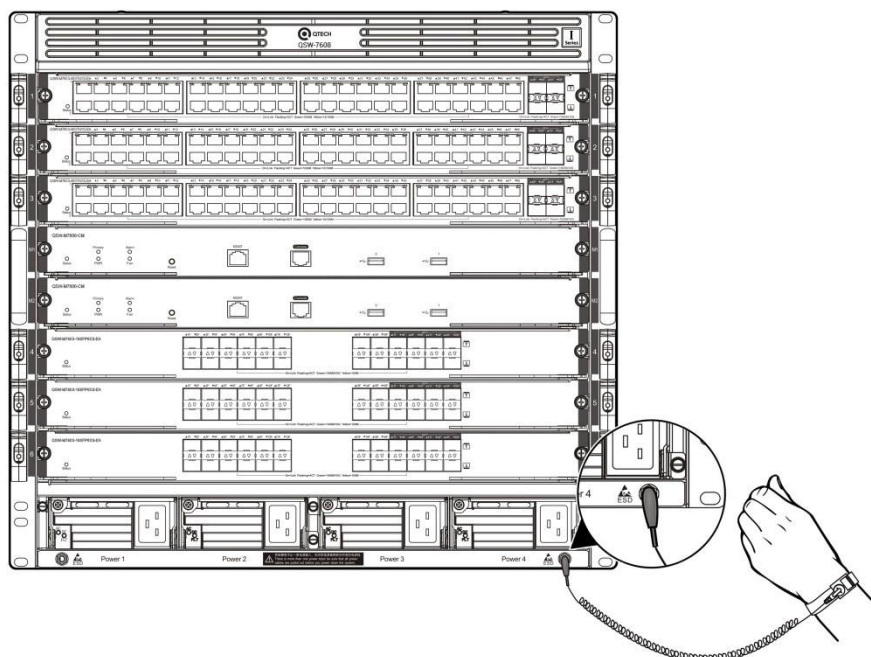
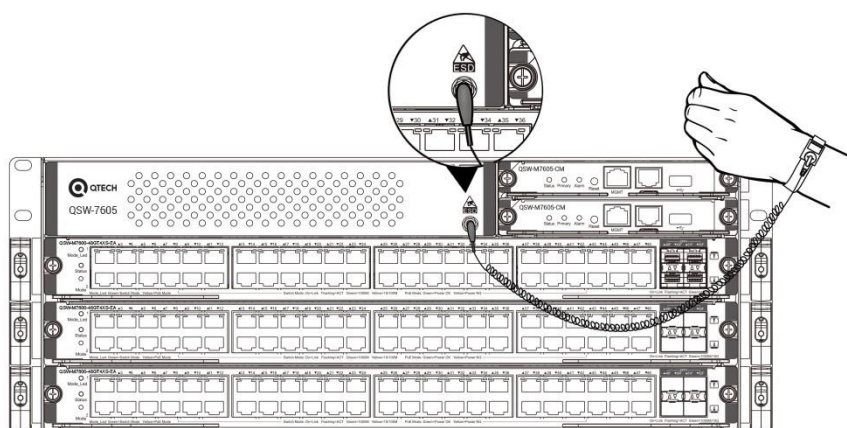

Figure 2-2 Preventing EMI on QSW-7605



2.1.5 Laser Safety

Among the modules supported by QSW-7600, there are a great number of optical modules that are Class I laser products.

Precautions:

- ❖ When a fiber transceiver works, ensure that the port has been connected with a fiber or is covered with a dust cap so as to keep out dust and avoid burning your eyes.
 - ❖ Do not stare into any fiber port.
-
- ⚠ Do not stare into any fiber port under any circumstances, as this may cause permanent damage to your eyes.
-

2.2 Installation Site Requirements

QSW-7600 must be used in the room. To ensure normal operation and a prolonged useful life of the equipment, the installation site must meet the following requirements.

2.2.1 Load Bearing Requirements

Evaluate the load bearing requirements for the ground according to the weight of the switch and its components (such as the cabinet, chassis, single board and power supply). Make sure the installation site meet the requirements.

2.2.2 Space Requirements

- ❖ It is recommended that the width of the machine room corridor be greater than 0.8m to ensure enough space for moving of chassis and plugging and removing of modules.
- ❖ Please do not install the switch against the wall. Instead, please leave some space around the switch for heat dissipation and switch maintenance.

2.2.3 Ventilation Requirements

See *QSW-7608* and *QSW-7605* in *Product Overview* for their heat dissipation and ventilation respectively. Sufficient space (10 cm at least) must be reserved at the air intakes and exhaust vents for ventilation. After connecting various cables, you should bundle the cables or place them in the cable management bracket to avoid blocking air intakes.

 Remove all foam packaging materials and protective plastics before you power on QSW-7608/QSW-7605.

2.2.4 Temperature Requirements

To ensure the normal operation and a prolonged useful life of the QSW-7600, you must maintain an appropriate temperature in the equipment room. Too high or low temperature for a long period of time may damage the equipment.

- ❖ In an environment with high temperature, the equipment is subjected to even greater harm, as its performance may degrade significantly and its useful life may be shortened in the case of long-term exposure that expedites the aging process.

Temperature Requirements of the QSW-7600

Operating Temperature	Storage Temperature
0°C to 50°C	-40°C to 70°C

-  The ambient temperature is measured at the point that is 1.5m above the floor and 0.4m before the equipment when there is no protective plate in front or back of the equipment rack.

2.2.5 Humidity Requirements

To ensure the normal operation and a prolonged use life of the QSW-7600, you must maintain an appropriate humidity in the equipment room. Too high or low humidity for a long period of time may damage the equipment.

- ❖ In an environment with high relative humidity, the insulating material may have bad insulation or even leak electricity, and sometimes the materials may suffer from mechanical performance change and metallic parts may get rusted.
- ❖ On the other hand, in an environment with low relative humidity, the insulating strip may dry and shrink, and static electricity may occur easily and endanger the circuit on the equipment.

Humidity Requirements of the QSW-7600

Operating Humidity	Storage Humidity
10% to 90% (non-condensing)	5% to 95% (non-condensing)

- i** The ambient humidity is measured at the point that is 1.5m above the floor and 0.4m before the equipment when there is no protective plate in front or back of the equipment rack.

2.2.6 Cleanness Requirements

Dust poses the top threat to the running of the equipment. The indoor dust falling on the equipment may be adhered by the static electricity, causing bad contact of the metallic joint. Such electrostatic adherence may occur more easily when the relative humidity is low, not only affecting the use life of the equipment, but also causing communication faults. The following table shows the requirements for the dust content and granularity in the equipment room.

Substance	Concentration Limit (particles/m ³)
Dust particles (diameter $\geq 0.5\mu\text{m}$)	$\leq 3.5 \times 10^6$
Dust particles (diameter $\geq 5\mu\text{m}$)	$\leq 3 \times 10^4$

- i** The air filter of the QSW-7600 must be cleaned at interval to ensure good ventilation and dust prevention.

Apart from dust, the salt, acid and sulfide in the air in the equipment room must also meet strict requirements; as such poisonous substances may accelerate the corrosion of the metal and the aging of some parts. The equipment room should be protected from the intrusion of harmful gases (for example, SO₂, H₂S, NO₂ and Cl₂), whose requirements are listed in the following table.

Gas	Average (mg/m ³)	Maximum (mg/m ³)
SO ₂	0.3	1.0
H ₂ S	0.1	0.5
NO ₂	0.5	1.0
Cl ₂	0.1	0.3

i The **Average** refers to the average limit of harmful gas in one week. The **Maximum** value is the upper limit of the harmful gas measured in one week for up to 30 minutes every day.

Dusting Cycle Suggestions:

i It is suggested to purchase an air filter and install it on the switch.

Clean the air filters every three months.

Dust the air intakes and exhaust vents of all modules every three months.

Dust the modules every one or two years.

Dust the fan shelves yearly.

Dust the chassis, including the backboard, every one or two years.

i If the device is in a poor dust prevention environment, please increase the dusting times.

2.2.7 Power Requirements

When the QSW-7608 can use the following power supplies:

❖ QSW-PA1600I-F, QSW-PA600I-F, QSW-PA300I-F power modules adopt 90 to 264 VAC/ 47 to 63 Hz input.

i Input power shall be larger than the actual power consumption of entire system. For example, the QSW-7608 chassis is installed with two QSW-M7608-CM, two QSW-M7600-48SFP4XS-EA and two QSW-M7600-36GT12SFP4XS-EA modules. The total power consumption of the device would be: 2 x 65W (QSW-M7600-CM) + 2 x 101W (QSW-M7600-48SFP4XS-EA) + 2 x 80W (QSW-M7600-36GT12SFP4XS-EA) + 176W (reserved power consumption for the whole switch) = 668W. It is recommended that you adopt one QSW-PA1600I-F or two QSW-PA600I-F modules.

The following table lists the power consumption of each module:

QSW-7608 Series Modules	Maximum Power Consumption (W)
-------------------------	-------------------------------

QSW-M7608-CM	65
QSW-M7605-CM	33
QSW-M7600-16SFP8XS-EA	95
QSW-M7600-24SFP/12GT4XS-EA	85
QSW-M7600-36GT12SFP4XS-EA	80
QSW-M7600-48GT4XS-EA	70
QSW-M7600-48GT4XS-P-EA	No PoE or PoE+ supply: <70W; PoE supply: <70W+15.4W x N (N stands for the number of PoE ports in use, no greater than 48); PoE+ supply: <70W+30W x N (N stands for the number of PoE+ ports in use, no greater than 48)
QSW-M7600-48SFP4XS-EA	101
QSW-M7600-24GT24SFP4XS-EA	88
QSW-M08-FAN	88

- ⚠ The QSW-7600 provides N+N redundancy of power supply. You are recommended to use multiple power supplies for the equipment to ensure its continuous and stable operation by avoiding the impact of unexpected power failures on the equipment.
- ⚠ When the dual power supply is applied, the type of the power supply should be identical.
- ⚠ If a power supply system is equipped with a leakage protector (also referred to as "leakage current switch" or "leakage current breaker"), the rated leakage action current of each leakage protector is greater than twice of the theoretical maximum leakage current of all the power supplies in the system. For example, if a system is equipped with eight identical power supplies, the leakage current of each power supply is equal to or less than 3 mA, and the leakage current of the system totals 24 mA. A leakage protector with 30 mA rated action current supports less than five power supplies (that is, Action current of the leakage protector/2/Maximum leakage current of each power supply = $30/2/3 = 5$). In other words, the leakage protector with 30 mA rated action current supports no more than four power supplies. In this case, the eight power supplies in the system require at least two leakage protectors with 30 mA rated action current and each leakage protector supports four power supplies. If power supplies in a system differ in models, the rated leakage action current of each leakage protector divided by two is greater than the sum of maximum leakage currents of all the power supplies. The rated leakage non-action current of a leakage protector shall be 50% of the leakage action current. Take a leakage protector

with 30 mA rated leakage action current as an example. The rated leakage non-action current shall be 15 mA. When the leakage current is below 15 mA, the protector shall not act. Otherwise, misoperation may easily occur due to high sensitivity and thus the leakage protector trips, devices are powered off, and services are interrupted.

⚠ To guarantee personal safety, the rated leakage action current of each leakage protector in the system must be equal to or less than 30 mA (human body safety current is 30 mA). When twice of the total leakage current of the system is greater than 30 mA, the system must be equipped with two or more leakage protectors.

⚠ For the leakage current value of each power supply model, see the power supply model parameter table in Chapter 1.

2.2.8 System Grounding Requirements

A good grounding system is the basis for the stable and reliable operation of the QSW-7600. It is the key to prevent lightning stroke and resist interference. Please carefully check the grounding conditions on the installation site according to the grounding requirements, and perform grounding properly as needed.

Safety Grounding

The equipment using AC power supply must be grounded by using the yellow/green safety grounding cable. Otherwise, when the insulating resistance decreases the power supply and the enclosure in the equipment, electric shock may occur.

⚠ The building installation shall provide a means for connection to protective earth, and the equipment is to be connected to that means.

Lightning Grounding

The lightning protection system of the facility is a separate system that consists of the lightning rod, down lead conductor and the connector to the grounding system, which usually shares the power reference ground and yellow/green safety cable ground. The lightning discharge ground is for the facility only, irrelevant to the equipment.

ℹ For lightning protection, see Appendix B.

EMC Grounding

The ground required for EMC design includes shielding ground, filter ground, noise and interference suppression, and level reference. All the above constitute the comprehensive grounding requirements. The grounding resistance should be less than 1Ω. One grounding point is reserved at the left back of the chassis. The grounding point is pasted with a conspicuous warning label.

2.2.9 EMI Consideration

Various interference sources, from either outside or inside the equipment or application system, affect the system in the conductive ways such as capacitive coupling, inductive coupling, and electromagnetic radiation. There are two types of electromagnetic interferences:

radiated interference and conducted interference, depending on the type of the propagation path. When the energy, often RF energy, from a component arrives at a sensitive component via the space, the energy is known as radiated interference. The interference source can be both a part of the interfered system and a completely electrically isolated unit. Conducted interference results from the electromagnetic wire or signal cable connection between the source and the sensitive component, along the cable the interference conducts from one unit to another. Conducted interference often affects the power supply of the equipment, but can be controlled by a filter. Radiated interference may affect any signal path in the equipment, and is difficult to shield.

- ❖ Effective measures should be taken for the power system to prevent the interference from the electric grid.
- ❖ The working ground of the routers should be properly separated and kept as far as possible from the grounding device of the power equipment or the anti-lightning grounding device.
- ❖ Keep the equipment away from high-power radio transmitter, radar transmitting station, and high-frequency large-current device.
- ❖ Measures must be taken to isolate static electricity.

2.3 Cabinet Mounting

Make sure the cabinet complies with the following conditions:

- ❖ Install the switch in a 19-inch cabinet in 4-port form hold.
- ❖ Be sure the distance between two square hole strips, one on each side, is 465 mm.
- ❖ Figure 2-2 19-inch Cabinet

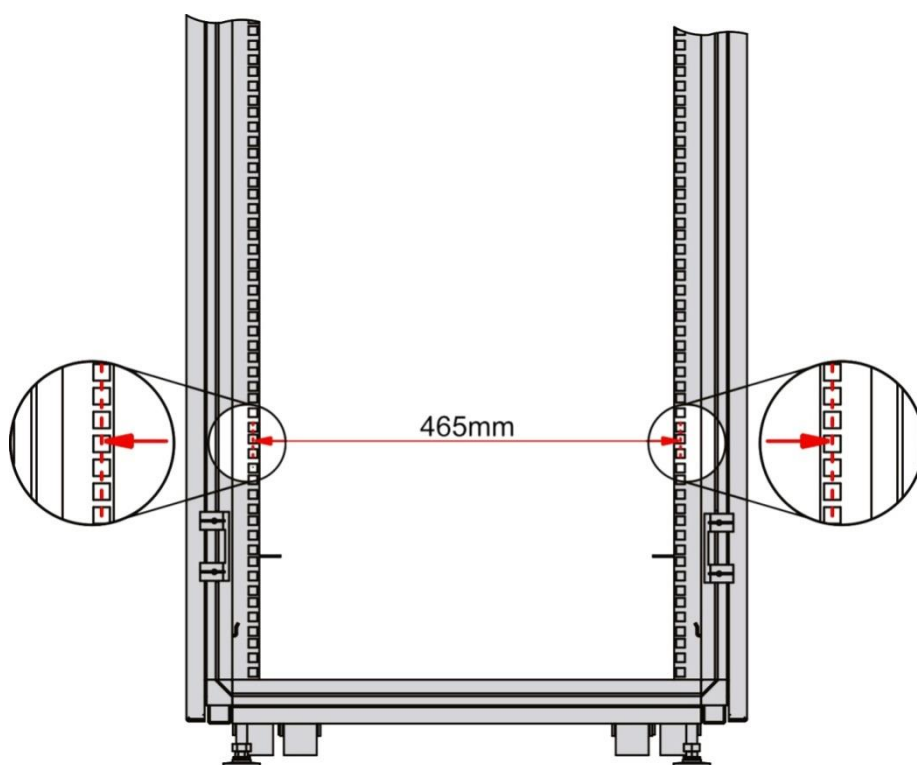

- ❖ Be sure that the square hold strip is at least 125 mm far from the outboard front door and the door is at most 25 mm thick to ensure a minimum available distance of 100 mm. The front door is at least 500 mm far from the back door,
- ❖ Figure 2-3 Cabinet Dimensions

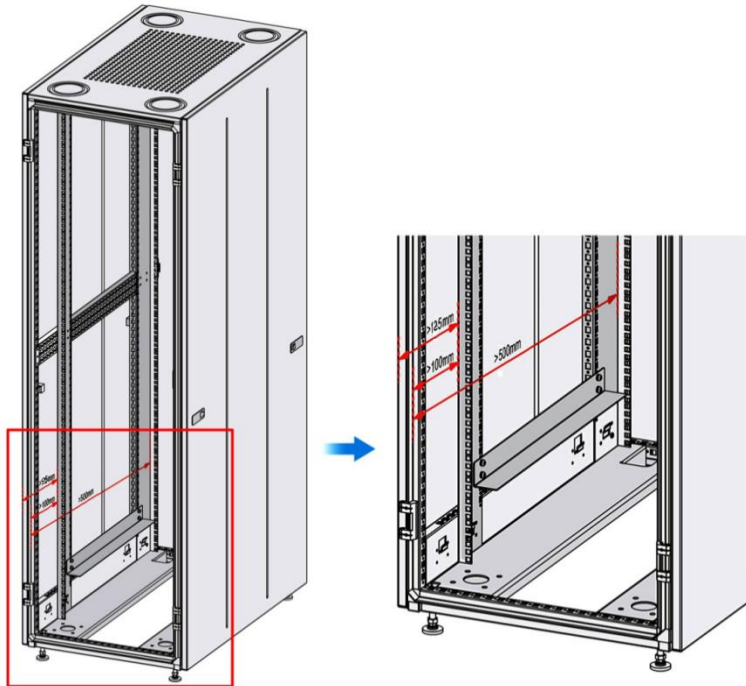

- ❖ Be sure that the slide rail in the cabinet is enough to bear the weight of a QSW-7608 and its installation accessories.
- ❖ Be sure that the cabinet provides an earthing terminal for the switch to be grounded.
- ❖ Be sure that the front and back doors of the cabinet have porosities greater than 50% for good ventilation and heat dissipation.

2.4 Installation Tools

Common Tools	Cross screwdriver, straight screwdriver, related electric and optical cables Bolts, diagonal pliers, straps
Special Tools	Anti-static glove, stripping pliers, crimping pliers, crimping pliers for the crystal head, wire cutter
Fiber Optic Cleaning Tools	Air-laid paper, optical fiber microscope
Meter	Multimeter, bit error rate tester (BERT), optical power meter

 The tool kit is customer supplied.

2.5 Precaution for Fiber Connection

Before connecting fiber cables, make sure the model of the optical transceiver and fiber type match the optical port. The transmit port on the local device should be connected to the receive port on the peer device and vice versa.

2.6 Unpacking Requirements

Goods Checklist

Chassis Carton	Device panels are installed and operational. Fans, screwdriver, anti-static wrist strap, yellow/green grounding wires, quick installation guide, packing list
Module Carton	Modules, packing list, documentation

 A normal delivery should contain the above mentioned items, which may differ from the actual delivery, depending on purchase contracts. Please check your goods carefully against the packing list or purchase contract. If you have any questions or there are any errors, please contact your distributor.

3 PRODUCT INSTALLATION

QSW-7608 series Ethernet switch must be used and fixed in the room.

- ❗ Make sure you have carefully read part 2 and this part, and be sure that the requirements set forth in part 2 have been met.

3.1 Installation Procedure

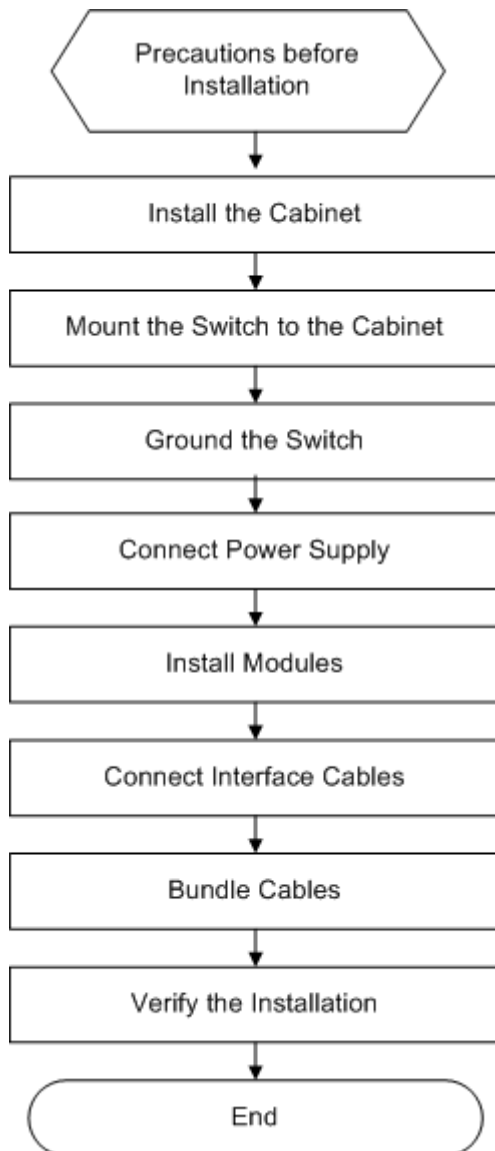

3.2 Installation Verification

The QSW-7600 is complicated equipment, so you must carefully plan and arrange the installation location, networking mode, power supply, and wiring before installation. Verify the following before installation:

- ❖ The installation location is of a good air flow.

- ❖ The installation location meets the temperature and humidity requirements of the equipment.
- ❖ The qualified power supply is available at the installation location.
- ❖ The related network cables have already been deployed at the installation location.
- ❖ The selected power supply meets the system power.

3.3 Installing the Air Filter (Optional)

Install air filters of the supervisor module and service module on the QSW-7608. The air filter is not supported on QSW-7605.

⚠ If an air filter is used for a long time, dust may block its air vent, weakening system ventilation. It is recommended you wash the air filter every three months.

Installing the Air Filters of the Supervisor Module and Service Module

QSW-7608

Figure 3-1 Air Filter Location of the Supervisor Module and Service Module on QSW-7608 Switch

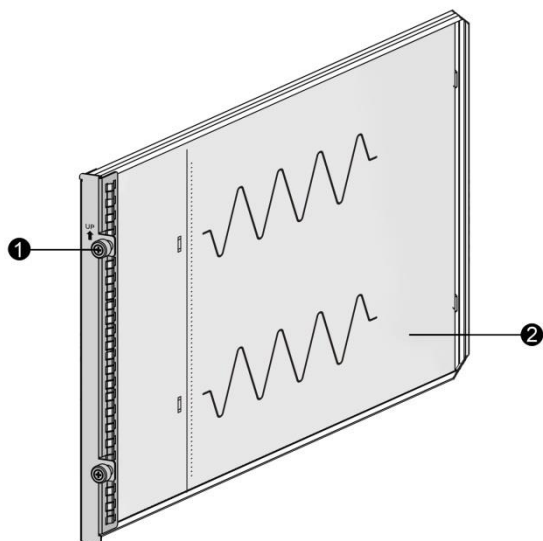

Note:

① Captive screw

② Air filter

- ❖ To install the air filter , follow these steps:
 1. Insert the air filter along the slide rail. Note the instruction on the air filter to ensure that the air filter is installed properly.
 2. Tighten the captive screws on the air filter with a screwdriver.

Figure 3-2 Installing the Air Filter of the Supervisor Module and Service Module on QSW-7608 Switch

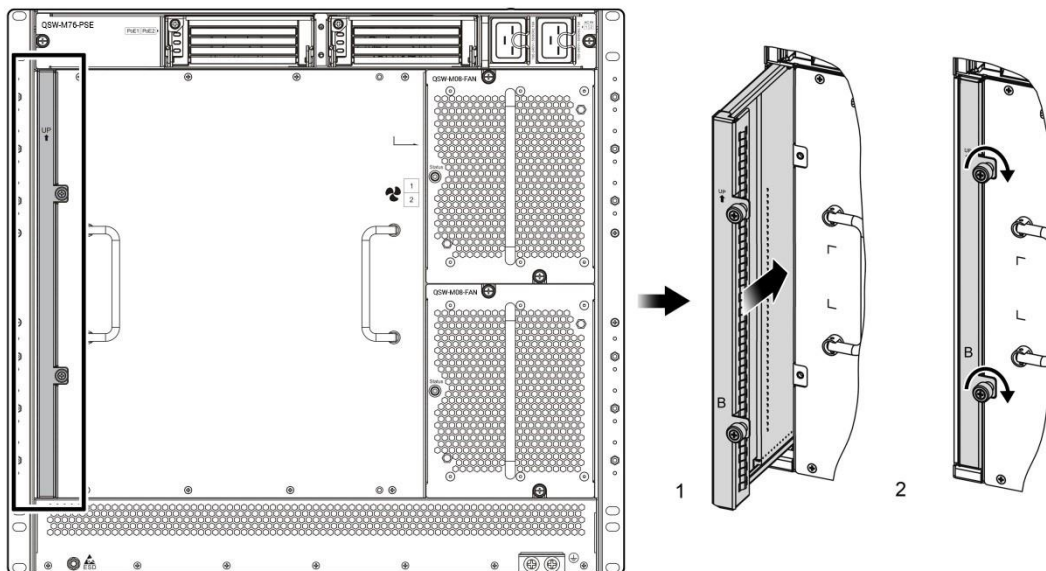

3.4 Installing the PoE Frame (Optional)

Please refer to *QSW-M76-PSE* for installing QSW-M76-PSE on the QSW-7608. The PoE frame is not supported on the QSW-7605.

⚠ If installed modules requiring PoE power supply, such as QSW-M7600-48GT4XS-P-EA, then both PoE frame and PoE power supply are needed.



❖ Install the PoE frame on the QSW-7608

1. Insert the frame into the slot along the rail. Note the direction identifier of the frame to ensure the correct direction.
2. Tighten the captive screws on the power module to fix it.

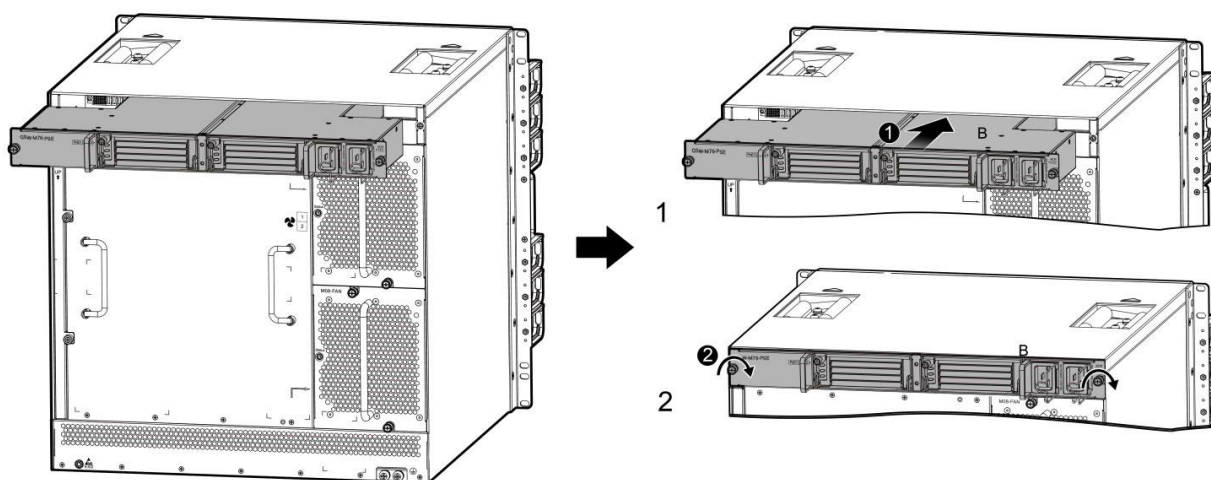
Figure 3-3 Installing the PoE frame on the QSW-7608



3.5 Mounting Cable Management Brackets

-  Make sure the antistatic wrist strap is grounded well and wear the antistatic wrist strap.
-  The QSW-7600 cable management bracket is not mounted before delivery. See the following steps and figures for installation.

❖ Mount the cable management bracket for QSW-7608

1. Take out cable management brackets.
2. There three cable management brackets on each side respectively. Pay attention to the direction to mount cable management brackets, as shown in figure 3-4.
3. Align the screw holes on the cable management bracket with those on the chassis and tighten the screws, as shown in figure 3-4.

Figure 3-4 Mounting the Cable Management Bracket for QSW-7608

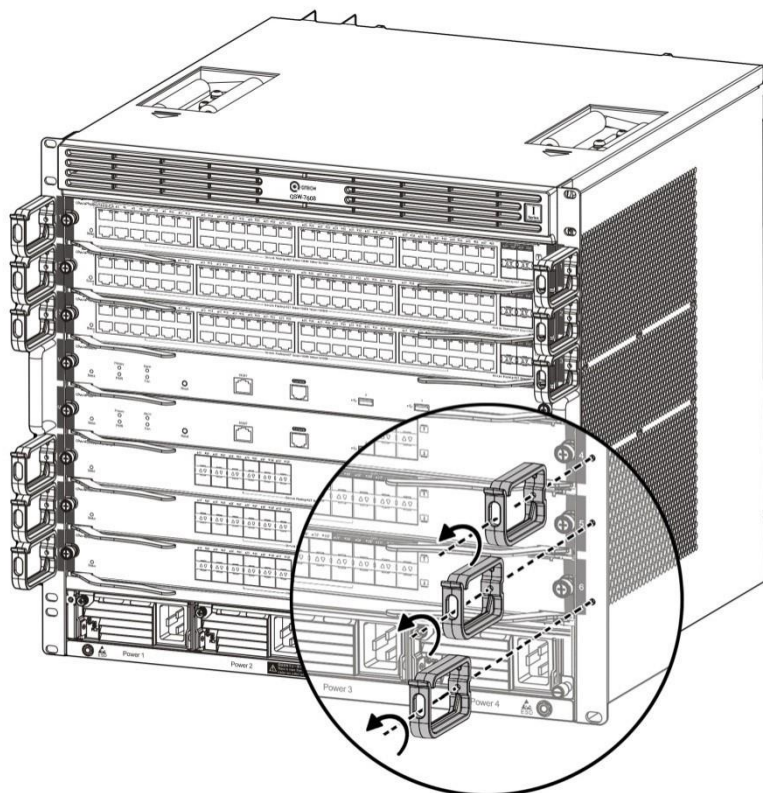

❖ Mount the cable management bracket for QSW-7605

1. Take out cable management brackets.
2. There three cable management brackets on each side respectively. Pay attention to the direction to mount cable management brackets, as shown in figure 3-5.
3. Align the screw holes on the cable management bracket with those on the chassis and tighten the screws, as shown in figure 3-5.

Figure 3-5 Mounting the Cable Management Bracket for QSW-7605

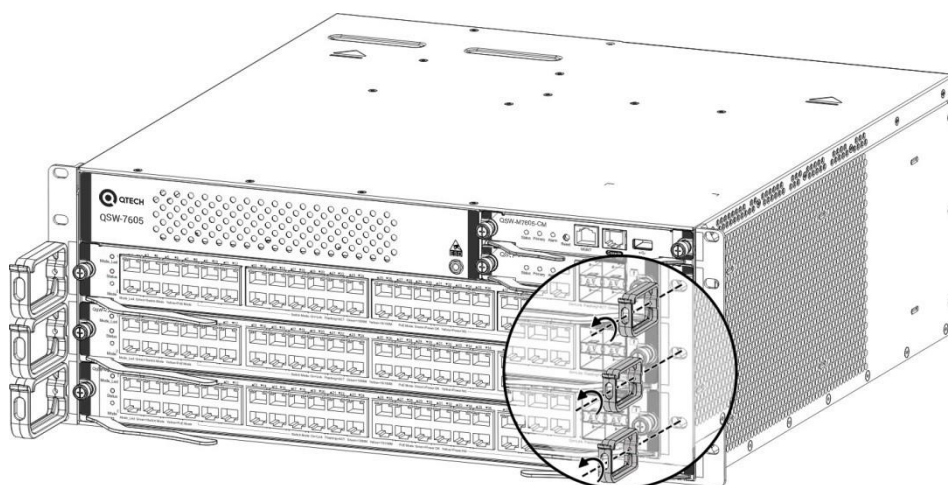

3.6 Mounting the Cabinet

Precautions

When you install the cabinet, pay attention to the following:

- ❖ All expansion bolts for fastening the cabinet base to the ground should be installed and tightened in sequence from bottom up (large plain washer, spring washer, and nut), and the installation holes on the base and the expansion bolts should be well aligned.
- ❖ After the cabinet is installed, it should be stable and still.
- ❖ After the cabinet is installed, it should be vertical to the ground.
- ❖ When multiple cabinets are put side by side in the room, they should be aligned in a straight line, with an error less than 5 mm.
- ❖ The front/back doors of the cabinet should be properly installed. You can open and close them smoothly. The locks should work normally, and all keys should be complete.
- ❖ There should be no unnecessary formal labels inside the cabinet and on various boards.
- ❖ Blank panels should be installed completely.
- ❖ Fastening screws of various devices in the cabinet of the same model should be ready and tightened.
- ❖ Various boards of the equipment should be installed securely, and the fastening screws on the panel should be tightened.
- ❖ All wiring inlets at the top and bottom of the cabinet should be installed with rodent-resistant nets where the seams should be no more than 1.5 cm in diameter, to prevent rodents and other small animals from entering the cabinet.
- ❖ Antistatic wrist straps should be provided in the cabinet.

Installation Steps

1. Reserve sufficient space for front and back doors of the cabinet for maintenance.
2. Mount the cabinet at the designed location as planned.
3. Install the appropriate cable management bracket and cables.
4. Install the tray and wiring layer on the rack according to the configuration of one rack with one cabinet installed or one rack with multiple cabinets installed.

Installing Slide Rails

Before installing a slide rail, you need to have some knowledge of standard 19-inch cabinets of IEC60297. The height of standard cabinets is measured in Rack Unit (RU, 1 RU = 44.45 mm (1.75 inch)). 1 RU is equal to the height of three holes (see Figure 3-5). The hole in the middle is an auxiliary installation hole, and the other holes are standard installation holes. Note that the space between neighboring standard installation holes is a little smaller than that between an auxiliary installation hole and its neighboring standard installation hole. When installing a slide rail for the QSW-7608 series, ensure that the plane to carry the chassis should be installed on the plane of delimiters (entire-U delimiter) of the two neighboring RUs as shown in Figure 3-6.

Figure 3-6 Slide Rail

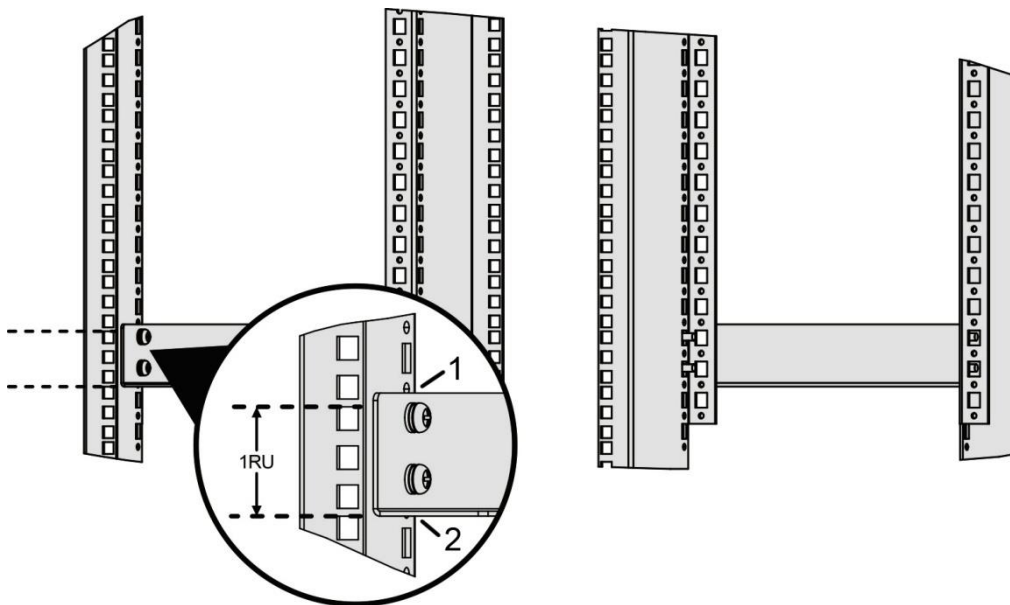

Note: ① and ② representing entire-U delimiters

- ⚠ Before installing a slide rail, make sure that the weight capacity of the slide rail meets requirements.
- ⚠ There are variable kinds of slide rails. The rail appearance and installation is subject to actual conditions.
- ⚠ In order to keep the cabinet balanced, please install the slide rail to as low a position as possible in the cabinet if only one QSW-7600 switch is installed. If you are mounting multiple devices to the cabinet, mount the heaviest device in the lowest position of the cabinet first and proceed to mount the rest of the devices from bottom to top.
- ⚠ It is recommended to install the power socket after planning on available space properly. Otherwise, there may be problems for operation.

3.7 Mounting the Switch to a Cabinet

Precautions

Before mounting QSW-7600 into the cabinet, first verify that the front and back brackets of the cabinet are at the right locations. If the bracket is too far forward, the front panel of the equipment may be too close to the front door, so that the front door cannot be closed when network cables and pigtail fibers are connected. Usually, you should reserve at least 10mm between the front panel of the equipment and that of the cabinet after installation. Before mounting into a cabinet, you need to address the following conditions:

- ❖ Fasten the cabinet.
- ❖ Insert various modules in the frame properly.
- ❖ Remove any obstacle in the frame and the surrounding environment.
- ❖ Prepare the equipment and move it to the place near the cabinet where you can handle it easily.

i Three people are recommended to carry or lift the switch. One is responsible for directing and the other two carrying or lifting the switch.

Installation Steps

Measure the cabinet height and locate the position on the bracket for installing the slide rail. Then locate the position on the other bracket through the carrying plane and mark the locations. Install seven cage nuts on the marked square holes on each bracket as shown in figure 3-7.

Figure 3-7 Slide Rail Installation Positions

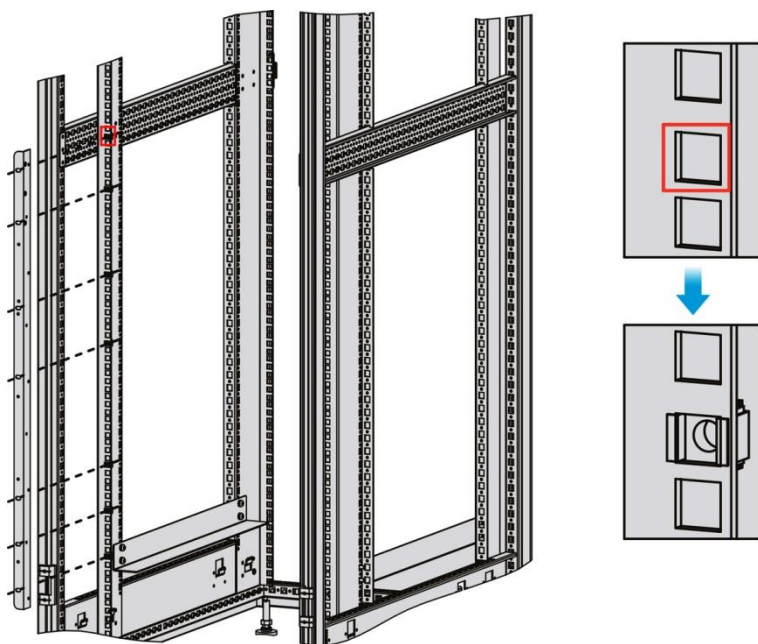

Place the switch on the slide rail, and drive it smoothly into the cabinet until the front bracket reaches the square hole strip.

Align the installation holes on the bracket with the cage nuts on the square hole strip, and mount them with screws.

Figure 3-8 Mounting the Switch into the Cabinet

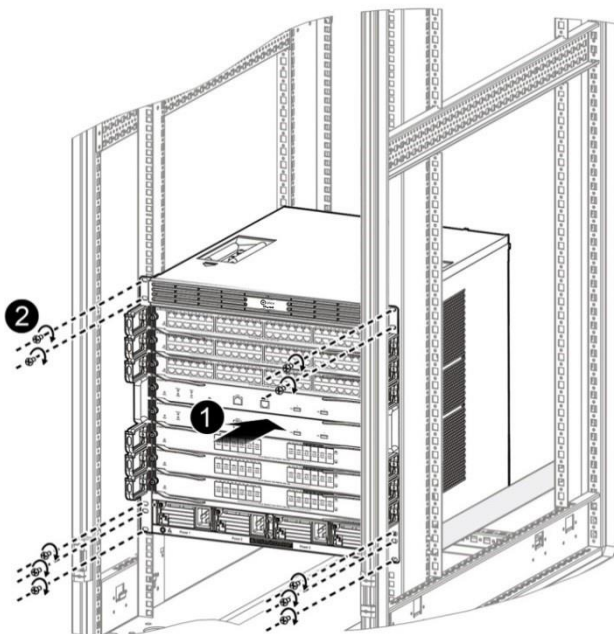

3.8 Connecting the System Ground

i A good grounding system protects your switch against lightning strikes and interferences and ensures its normal operation and reliability.

Precaution

- ❖ The sectional area of the grounding wire should be determined according to the possible maximum current. Cables of good conductor should be used.
- ❖ Do not use bare wire.
- ❖ The grounding resistance for combined grounding should be less than 1Ω .

Connecting the System Ground

To connect the system ground, follow these steps:

1. Remove the two screws on the rear of the switch.
2. Attach the one end of the grounding wire to the switch with the two screws. Connect the other end of the grounding wire to the grounding wire of the cabinet.

Figure 3-9 Grounding Point on the Rear of the QSW-7608 Switch

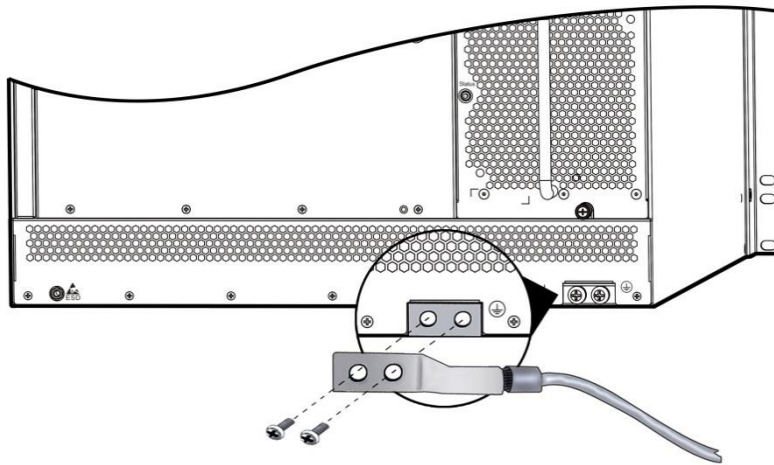
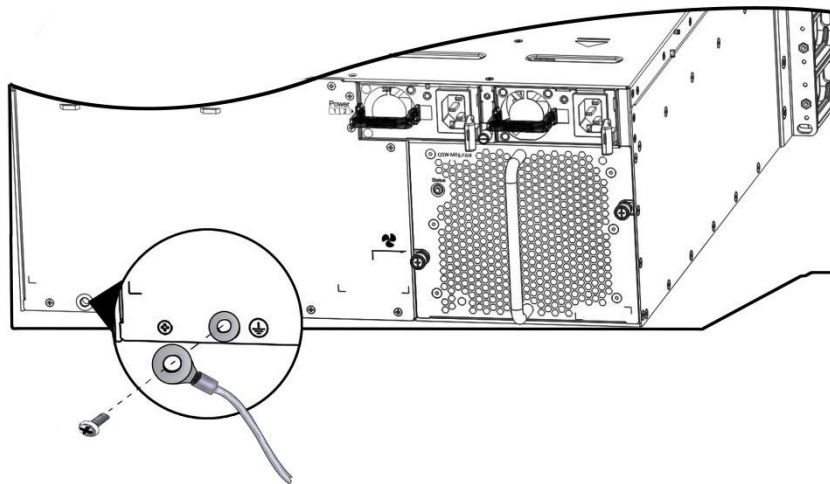

Figure 3-10 Grounding Point on the Rear of the QSW-7608 Switch



- ⚠ To guarantee the security of the person and the device, the QSW-7600 must be well-grounded. The grounding resistance shall be less than 1Ω .
- ⚠ A service person shall check whether or not the socket-outlet from which the equipment is to be powered provides a connection the building protective earth. If not, the service person shall arrange for the installation of a protective earthing conductor from the separate protective earthing terminal to the protective earth wire in the building.
- ⚠ The socket-outlet shall be installed near the equipment and shall be easily.
- ⚠ When installing the unit, always make the ground connection first and disconnect it last.
- ⚠ The cross-sectional area of protective earthing conductor shall be at least 2.5 mm^2 (12AWG).

3.9 Installing Power Supplies

The QSW-7608 series switches provide two system power supplies: QSW-PA1600I-F and QSW-PA600I-F AC power supplies, and two PoE power supplies: QSW-PA3000I-PL and QSW-PA1600I-PL. The QSW-7605 series switches provide two system power supplies: QSW-PA300I-F and

QSW-PA460I-F. Before performing the following procedures, wear an anti-static wrist strap close to your kin and keep it grounded well.

- ❗ The QSW-7608 power system provides four power supply slots, which support 1+1 redundancy. The power system also provides two PoE ports.
- ❗ The QSW-7605 power system provides two power supply slots, which support 1+1 redundancy.
- ❗ When QSW-7608/QSW-7605 is powered up by more than one source, the power must be in the same model.
- ❗ If you want to carry or lift the power module, please hold the bottom of the module with your hand instead of carrying the module by the handle. Otherwise, the module may be damaged.
- ❗ Before inserting or removing the power module, please verify whether the switch is well mounted. The switch is high, avoid switch tumble when you are inserting or removing the power module.
- ❗ If you want to hot swap a power supply, please make sure that the interval between two operation is greater than 30 seconds.
- ❗ Please do not touch the connecting finger part of the power supply which is removed after power off in case that capacitor discharge is not full.

❖ Install the AC power module on QSW-7608

1. Loosen the captive screws on the filler panel covering the power slot at the rear of the chassis.
2. Insert the power module into the slot along the rail until the rear connector of the power module stays in good contact with the rear panel.
3. Tighten the captive screws on the power module to fix it.

Figure 3-11 Installing Power Supplies

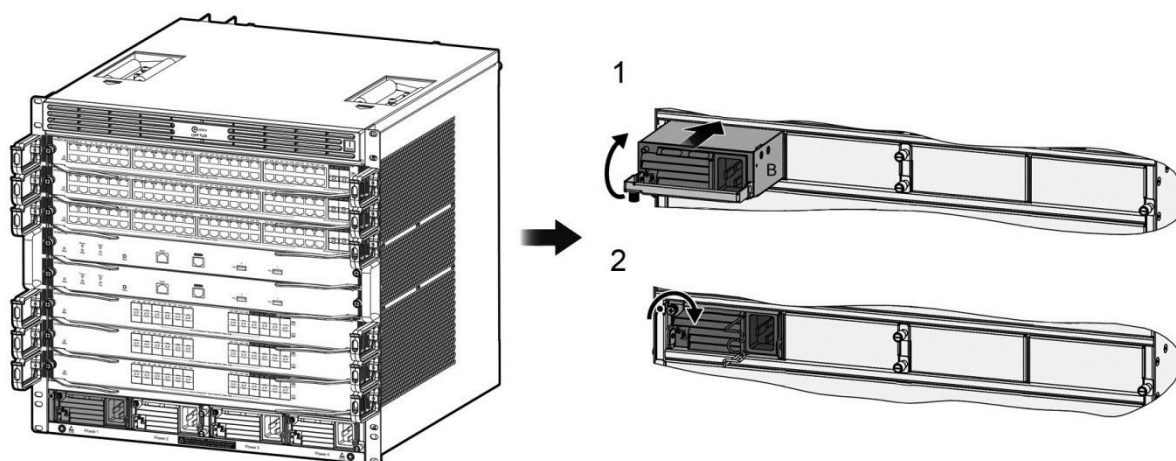

❖ Install the PoE power system

Take the same installation steps as the AC power installation.

❖ Install the AC power system on QSW-7605

1. Loosen the captive screws on the blank panel covering the power slot at the rear of the chassis.
2. Insert the power module into the slot along the rail until the power module clicks into place.

Figure 3-12 Installing AC Power Supplies on QSW-7605

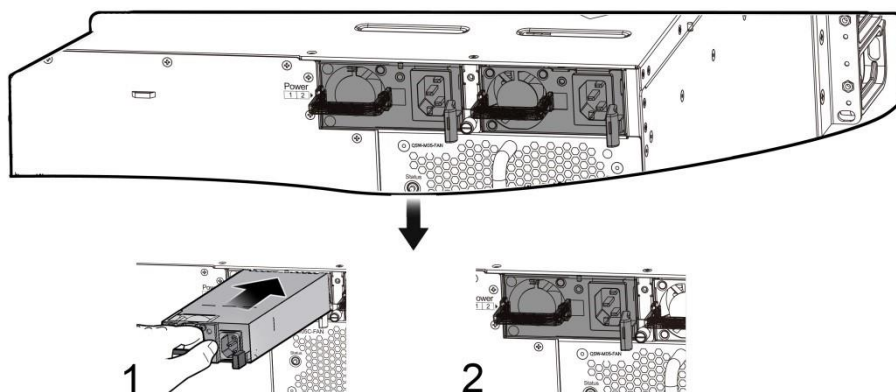

-
- !** The total power of power supplies of the QSW-7600 must be greater than the working power of the host. Otherwise, some modules may fail to start.
- i** The host power is the summation of the power of all working modules, including the supervisor module, service module and fan. For the power consumption of each module, see the module specifications.
-

3.10 Installing Fans

QSW-7608 and QSW-7605 adopt QSW-M08-FAN and QSW-M05-FAN module for heat dissipation respectively. Before the following procedures, wear an anti-static wrist strap close to your skin and have it properly grounded.

❖ Steps for installing the QSW-M08-FAN fan tray:

1. Install the fan tray into the fan slot in the rear panel of QSW-7608. Note the direction identifier of the fan tray's name to ensure the correct direction.
2. Tighten the captive screws on the fan tray with a screwdriver.
3. Figure 3-13 Installing QSW-M08-FAN Fan Tray

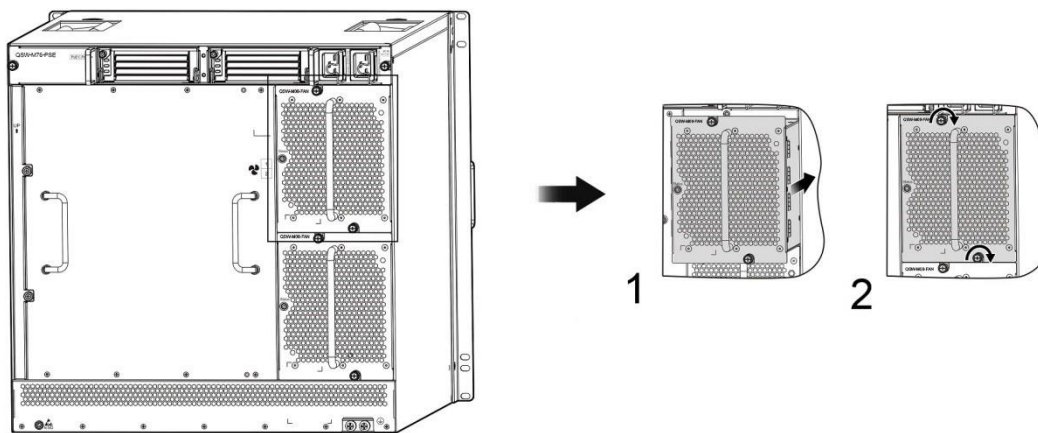

❖ Steps for installing the QSW-M05-FAN fan tray:

1. Install the fan tray into the fan slot in the rear panel of QSW-7605. Note the direction identifier of the fan tray's name to ensure the correct direction.
2. Tighten the captive screws on the fan tray with a screwdriver.
3. Figure 3-14 Installing QSW-M05-FAN Fan Tray

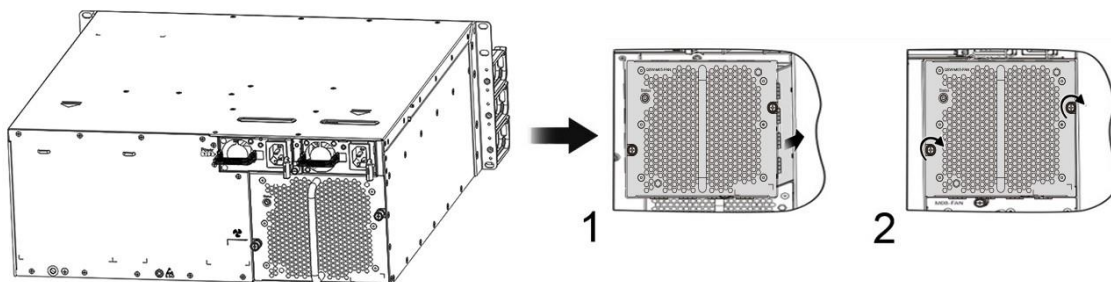

! Do not remove the fan tray forcibly. You can use the fan handle. Otherwise, component damage may occur, which causes deformation of the fan tray, and the fan tray cannot be removed.

3.11 Installing Modules

Always wear an anti-static wrist strap when installing the module and the metallic part of the anti-static wrist strap should be fully touched with the skin. Besides, for the sake of security, please not touch any component of the module.

- ⚠ Do not hold the edge of the PCB or collide the components on the PCB.
- ⚠ Do not plug/unplug a supervisor module, service module or switch fabric module forcedly, use the ejector.

❖ Select Slots

- i For the slot location of the supervisor module and service module, please see figure 3-15 and 3-16.

Figure 3-15 QSW-7608 Chassis

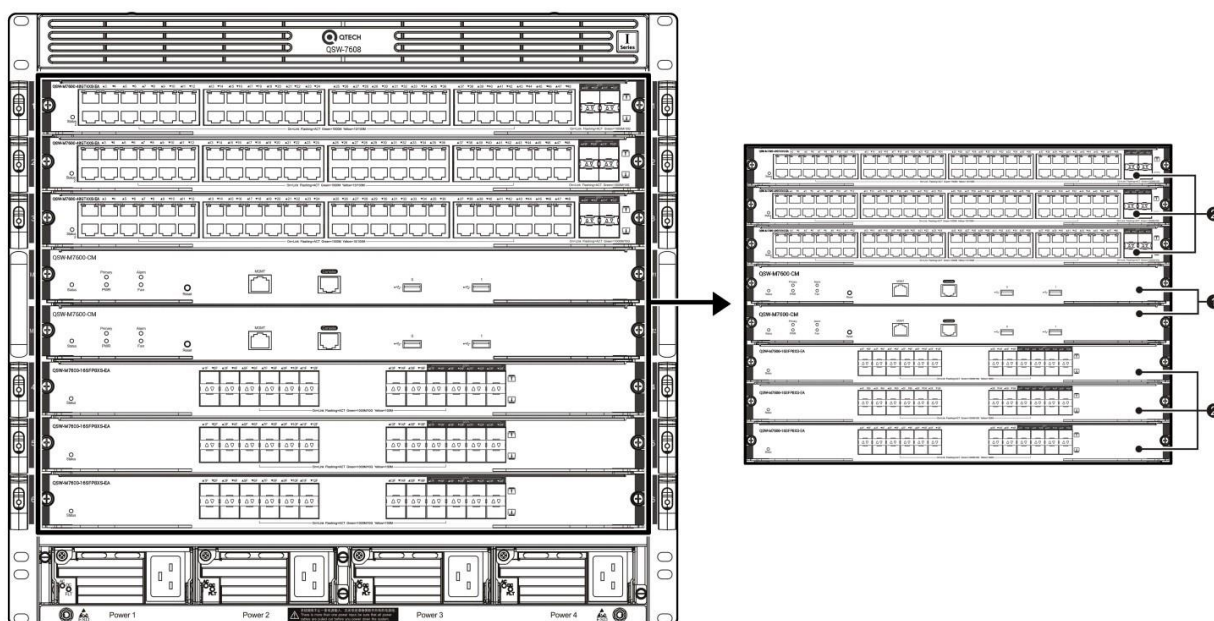

Note: ① Supervisor module slot ② Service module slot

Figure 3-16 QSW-7605 Chassis

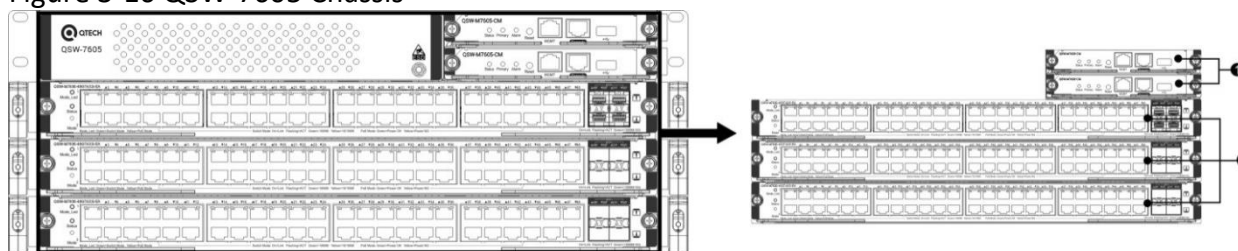

Note: ① Supervisor module slot ② Service module slot

❖ Install modules

- i See the following figure for installing the supervisor module and the service module.
- Steps for installing the QSW-7608 module:

1. Pull out both levers (① in figure 3-17).
2. Insert the module into the slot along the slide rail and drive it ahead smoothly (② in figure 3-17).
3. Push both levers toward the slot (③ in figure 3-17).
4. Tighten the captive screws on the fan tray with a screwdriver (④ in figure 3-17).

Figure 3-17 Installing the QSW-7608 module

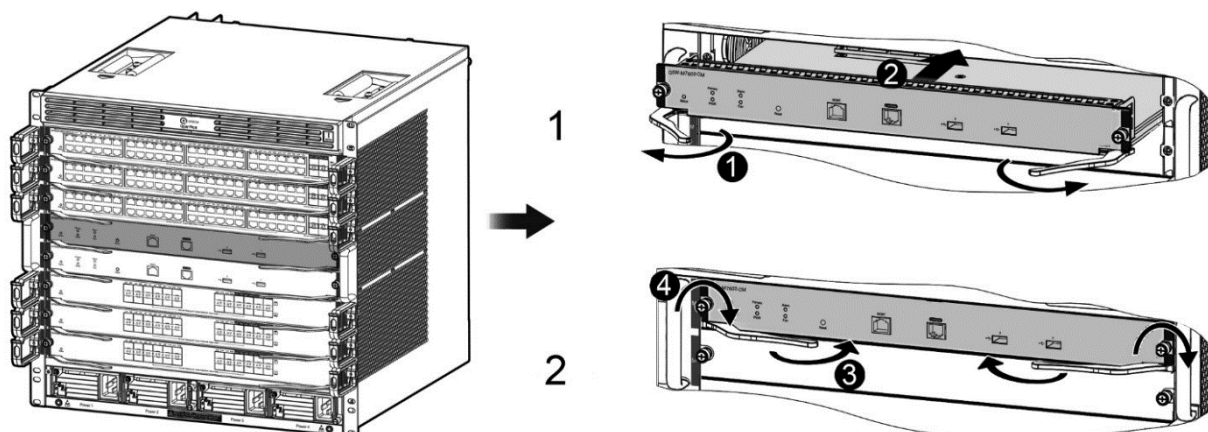

❖ Steps for installing the QSW-7605 module:

1. Pull out both levers (① in figure 3-18).
2. Insert the module into the slot along the rail and drive it ahead smoothly (② in figure 3-18).
3. Push both levers toward the slot (③ in figure 3-18).
4. Tighten captive screws on both sides of the panel (④ in figure 3-18).

Figure 3-18 Installing the QSW-7605 module

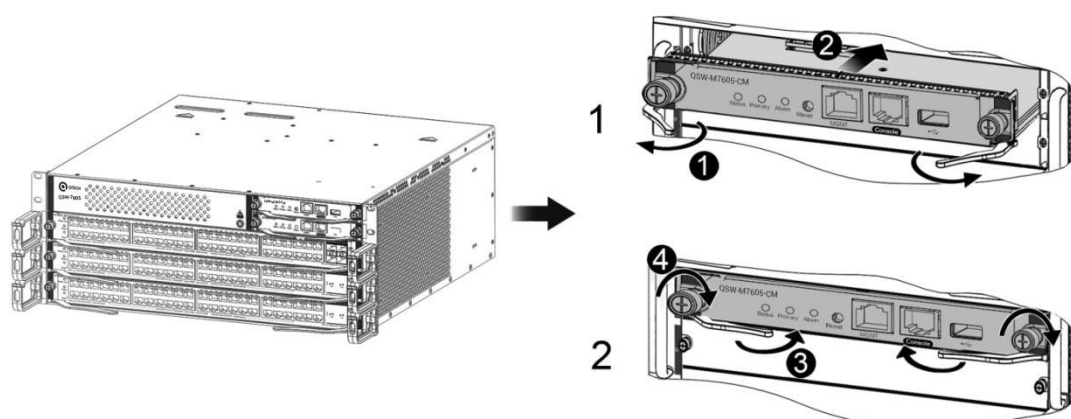

3.12 Installing Swappable Interface Modules (Optional)

! Make sure the optical modules connected to both ends of a fiber are the same type while replacing swappable optical modules.

Preparation

1. Wear an anti-static wrist strap to your wrist and tighten the lock. Make sure it is properly grounded.
2. Take out the SFP+/SFP/QSFP+ module you want to install from packing bag. Do not touch the connecting finger on the module.

Figure 3-19 Wearing an Anti-Static Wrist Strap

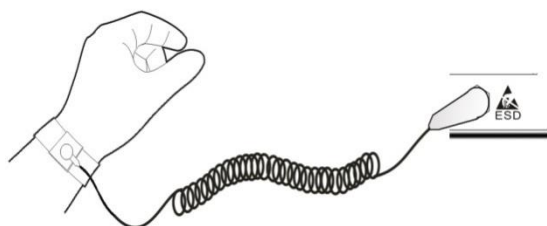

3.12.1 Installing SFP+/SFP Modules

! To avoid damaging components due to operation errors, read this section carefully before installing SFP+/SFP modules.

To install the SFP/SFP+ module, do as follows:

1. Turn up the handle of the module into the top bail-clasp latch. Hold both sides of the module and push the module into place (You can feel that the module is placed in position with a click sound).

Figure 3-20 Installing the SFP/SFP+ Module

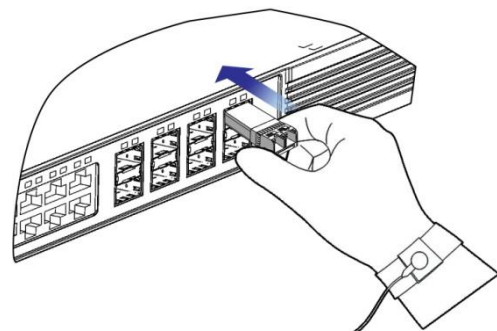

2. Use the fiber optical patch cord to connect the SFP/SFP+ module to the fiber optical network. Select the patch cord with the connector corresponding to the port.
3. After the patch cord is connected, the Link/ACT Status LED is on. Otherwise, please check connection of the patch cord.

Precaution

- ❖ If the SFP/SFP+ module cannot be inserted to the end, do not push it forcefully. Please try the other end of the module.
- ❖ Do not touch the connecting finger on the module.
- ❖ Do not squeeze, bend or fold the optical fiber, which may cause system performance degradation or data loss.
- ❖ Do not remove the protective rubber plug from SFP+/SFP module before connecting fibers.
- ❖ Do not insert the SFP+/SFP module with a fiber into a slot. Unplug the fiber before installing the module.

3.12.2 Installing SFP+ Cables

 To avoid damaging components due to operation errors, read this section carefully before installing SFP+ cables.

1. To install the SFP+ copper module, do as follows: You can install the SFP+ copper module with power on. Hold the connector of a copper cable module with one hand and carry the cable to the front panel of the switch with the other. Push the module gently into the SFP+ module slot until you hear a click, indicating the module is correctly installed.
2. Figure 3-21 Installing SFP+ Copper Module

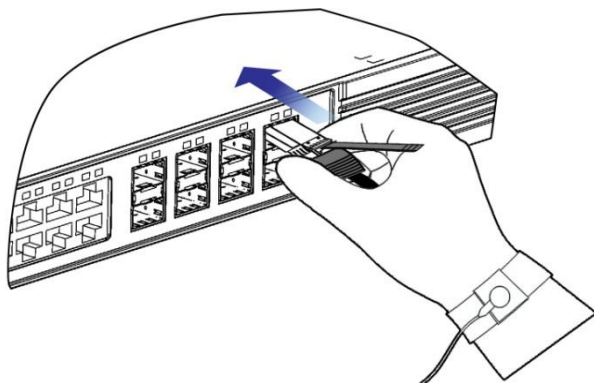

3. After you connect the copper module to the Ethernet network through the connector, the Link/ACT status is on. Otherwise, please check the connector.

Precaution

- ❖ If the SFP+ copper module cannot be inserted to the end, do not push it forcefully. Please try the other end of the module.
- ❖ Do not touch the connecting finger on the module.
- ❖ Do not squeeze, bend or fold the copper cable, which may cause system performance degradation or data loss.

 After the cable is plugged, make sure that the bending radius is greater than 5 times of the cable diameter. Too small bending radius may cause damage to the copper cable. For example, if the cable diameter is 4.9mm, the bending radius should be 24.5mm at least, as shown in figure 3-35:

Figure 3-22 Bending Radius and Cable Diameter



Use an SFP+ cable to connect two SFP+ ports close to each other. Take the following steps to install the SFP+ module:

1. Wear an anti-static wrist strap close to your skin and have it properly grounded.
2. Take out the SFP+ module you want to install from the packing bag.
3. Plug the SFP+ cable to the SFP+ port through the connector. Pay attention to the proper end for connection.

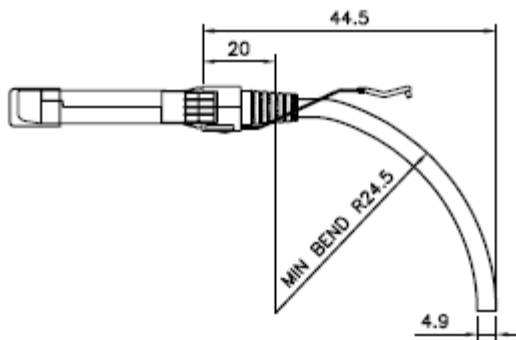
! During the operation, make sure that the cable's bending radius is no less than eight times as much as its diameter.

3.13 Connecting the Power Cord

Connect the power cord to the location as required according to the identification on the AC power module panel, including QSW-PA1600I-F, QSW-PA600I-F, QSW-PA300I-F, QSW-PA460I-F, QSW-PA3000I-PL and QSW-PA1600I-PL.

i Make sure the socket is powered off before the power cord is connected.

❖ Connect the AC power cord

1. Insert the AC power plug into the power module socket.
2. Take out the retention clip.
3. Install the retention clip on the front panel of the power module
4. Pull down the retention clip over the plug on the power cable..
5. Connect the other end of the power cord to an external power socket.

Figure 3-23 Connecting the Power Cord on QSW-7608

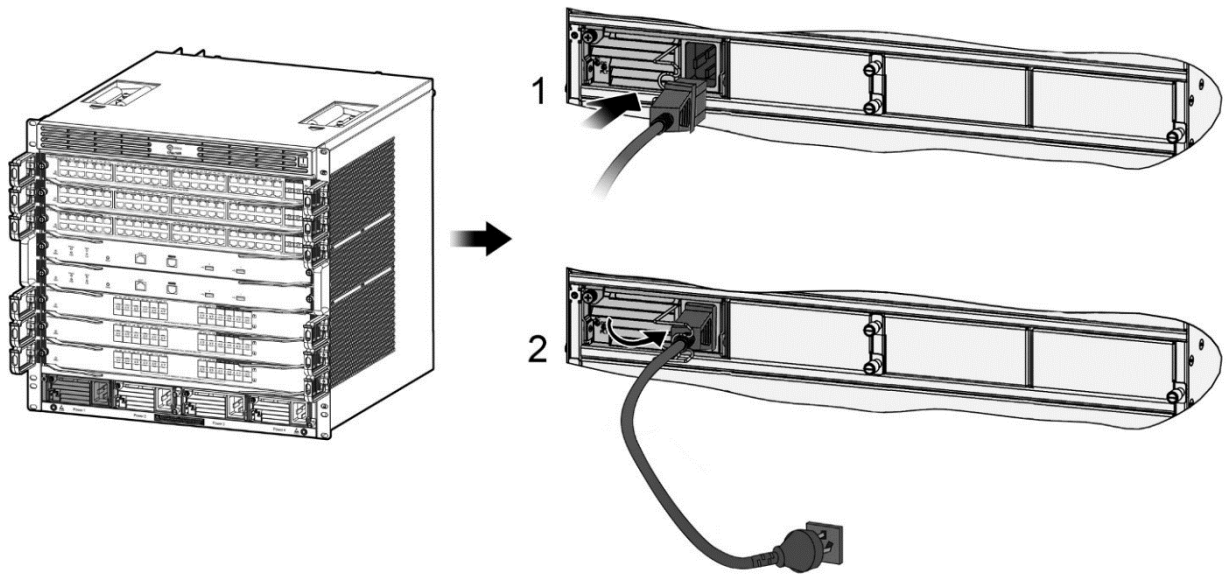
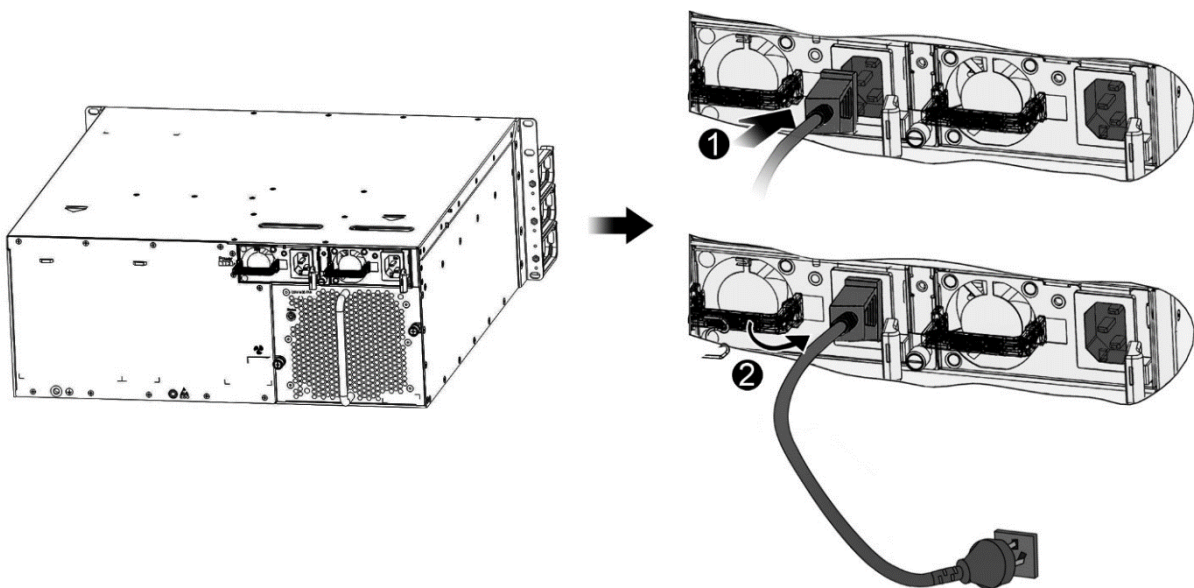

Figure 3-24 Connecting the Power Cord on QSW-7605



- ⚠ Please use the 3-pin power cord. The cross-sectional area of each pin is 1.5 mm² or 14 AWG minimum.
- ⚠ 16A and 10A power cords are available for the QSW-7608 AC power supply. Only 10A power cord is available for the QSW-7605 AC power supply. Adopt the proper socket and verify the AC power supply capacity in the machine room.

3.14 Installation Verification

- ❖ Verify if the external power supply matches the distribution panel of the cabinet.
- ❖ After installing the equipment, verify if the front/back cabinet doors can be closed.
- ❖ Verify that the cabinet has been fastened completely, and does not move or tilt.

- ❖ Verify that the equipment has been installed in the cabinet, and all the cables have been fastened to the cabinet.
- ❖ Verify that the fan meets the requirement.
- ❖ Verify that the power supply is properly selected.
- ❖ Verify that the power module is inserted properly and the screws are fastened tightly.
- ❖ Please do not power up the switch by yourself and do not perform live-line maintenance.
- ❖ Verify that there is no potential danger in the working area, for example, the power supply is not grounded well, or the ground is wet.
- ❖ Please do not place the switch at a damp place to prevent the moisture from entering the switch.
- ❖ Be sure of the location of the emergency power switch. If an emergency occurs, cut off the power first.
- ❖ Verify that all power supplies are turned off if you want to turn off the power.
- ❖ Verify that the power cord is connected properly.
- ❖ Verify that the power cord is long enough to avoid being stretched.
- ❖ Verify that the rated current of the external power socket is greater 16A and that the socket is grounded well.
- ❖ Verify that each power module is connected to a power socket.
- ❖ Verify that the vacant slot is covered with a filler panel for ventilation and heat dissipation.

4 SYSTEM DEBUGGING

4.1 Establishing the Configuration Environment

Establishing the Configuration Environment

i If you log in to the switch for the first time, please use the Console port.

Connecting the Console Cable

1. Connect one end of the DB-9 jack of the console cable to the serial port of the PC.
2. Connect one end of the console cable RJ45 to the Console port of the switch.

Figure 4-1 Connecting Switch and PC through Console Port

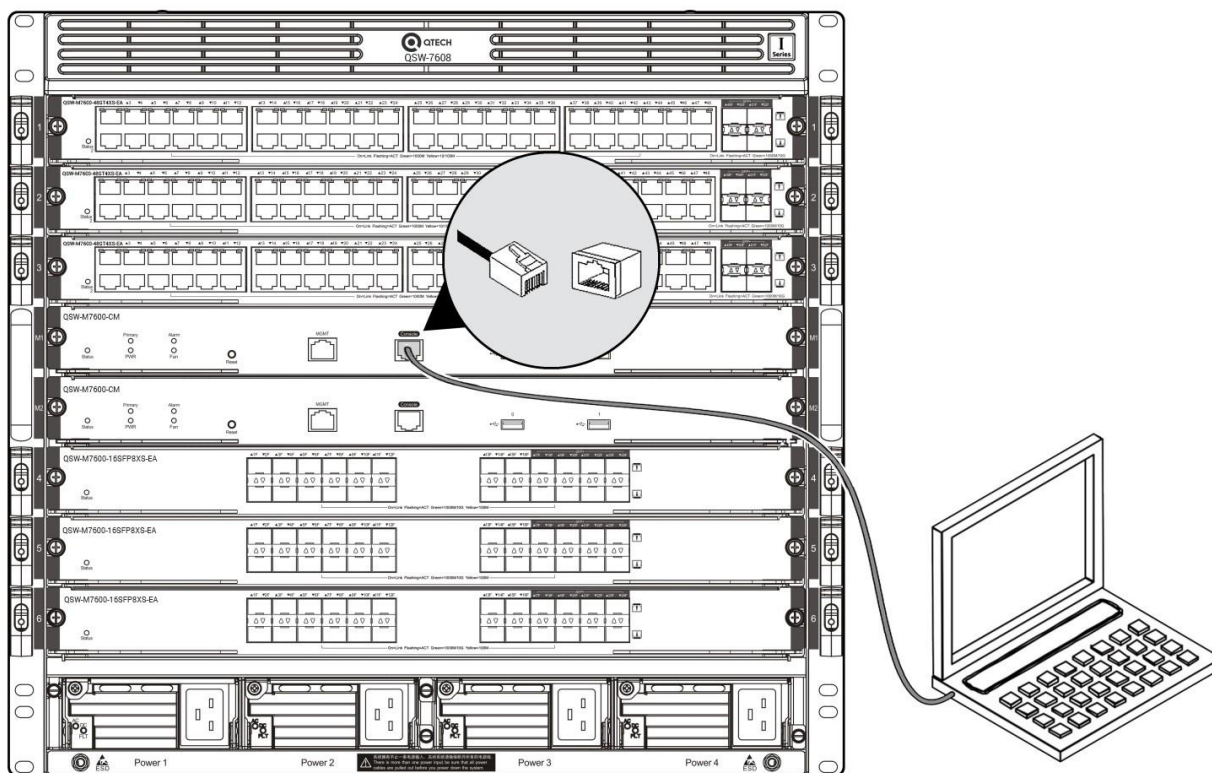

Setting Terminal Parameters

- ❖ Start the PC and run the terminal simulation program on the PC, such as Terminal on Windows 3.1 or HyperTerminal on Windows 95/98/NT/2000/XP.
- ❖ Set terminal parameters. The parameters are as follows: baud rate 9600, data bit 8, parity check none, stop bit 1, and flow control as none. Details are as follows:
 1. Choose Start > Programs > Accessories > Communications > Hyperterminal. The hyperterminal window appears.

2. Click Cancel. A window appears as shown in Figure 4-2.

Figure 4-2

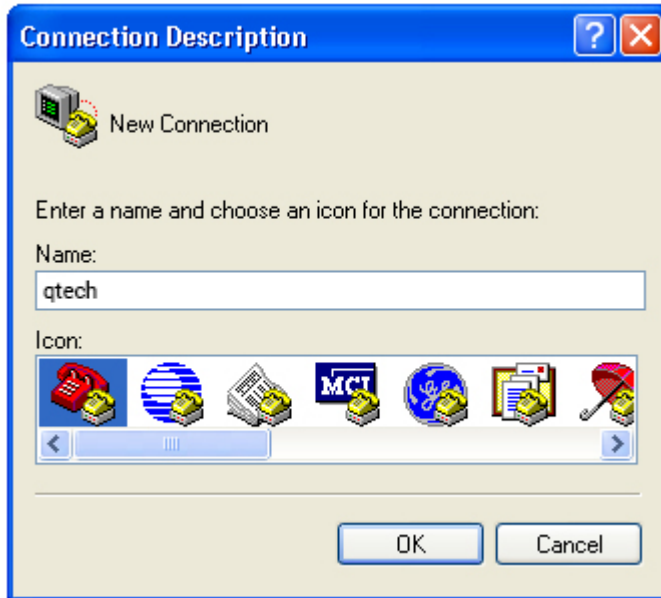

3. In the Connectivity Note window, type the name of the new connection and click OK. A window appears as shown in Figure 4-3. In the Connect Using field, select the serial port you want to use.

Figure 4-3



4. After selecting the serial port, click OK. The Serial Port Parameter Setting window is displayed, as shown in Figure 4-4. Set the baud rate to 9600, data bit to 8, parity check to none, stop bit to 1, and flow control to none.

Figure 4-4

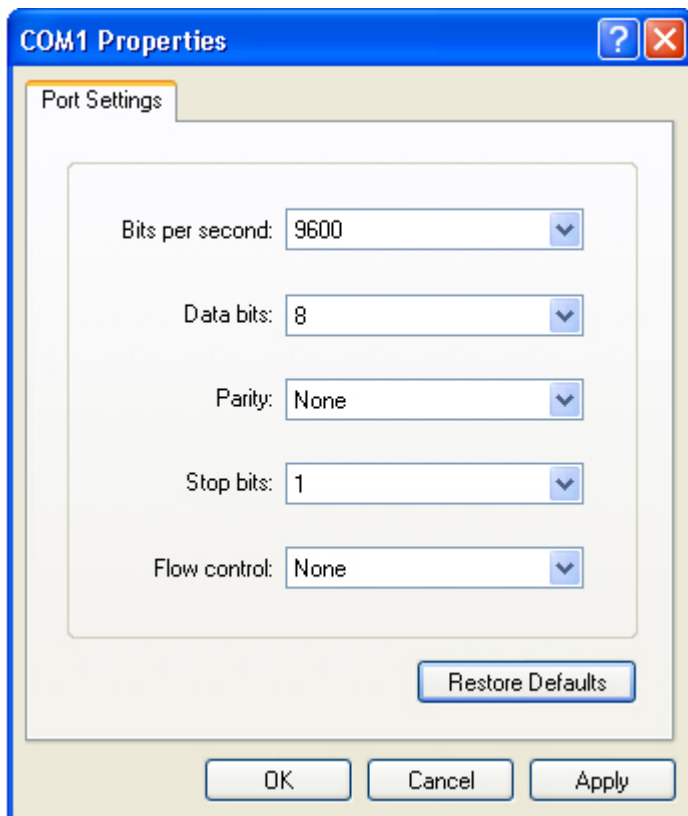

5. After setting the serial port parameters, click OK. The Hyperterminal window appears.

4.2 Power-on Startup

Checking Before Power-on

- ❖ The switch is fully grounded.
- ❖ The power cable is correctly connected.
- ❖ The power supply voltage complies with the requirement of the switch.
- ❖ The console cable is correctly connected; the terminal (can be a PC) used for configuration is already started; the parameters are already configured.

Checking After Power-on (Recommended)

After power-on, you are recommended to perform the following checks to ensure the normal operation of follow-up configurations.

- ❖ Check that information appears on the terminal interface.
- ❖ Check that the device indicator is normal.

5 MONITORING AND MAINTENANCE

5.1 QSW-7600 Monitoring

Indicators

When the QSW-7600 is running, you can monitor the status of each module by inspecting the status LED of the appropriate module.

- ❖ When the Alarm LED of the master supervisor module is red, it means the system has a fault, in which case you can log in to the management software to perform troubleshooting.
- ❖ When the Alarm LED of the master supervisor module is yellow, it means the system temperature exceeds the alarm temperature, affecting the system operation performance. However, the system can continue running. In this case, you can log in to the management software to perform troubleshooting.
- ❖ When the Status LED of the fan tray is red, it means that the fan tray is not power-on or the fan tray is faulty, you can log in to the management software to perform troubleshooting.
- ❖ When the Status LED of a module is OFF, RED, or blinking, it means that the module is faulty, in which case you need to find out the cause, and turn off the power when necessary.

CLI Commands

The QSW-7600 allows you to monitor various system statuses by executing the appropriate CLI commands, including:

- ❖ Module in-position status
- ❖ Port configuration information and status
- ❖ Fan and power supply working status
- ❖ Temperature status

-
- i For the monitoring commands, see QSW-7600 series Software Configuration Guide.
 - i QSW-7600 supports remote maintenance. If QSW-7608 and the Internet are connected, the user can log in to the QSW-7600 via Telnet and maintain QSW-7600 remotely through various monitoring commands.
-

5.2 Hardware Maintenance

Module Maintenance

To replace a module, do replacement according to the instructions provided in Sections of Installing Modules and Removing Modules.

Cooling System Maintenance

- ❖ The fan in the equipment is provided with the fault monitoring signals. When the fan fails, an appropriate alarm will occur.
- ❖ To replace the fan, first loosen the captive screw on the fan tray.
- ❖ Replace the failed fan with a good one.

❖ Tighten the captive screws of the fan tray.

⚠ Complete fan replacement within 30 seconds when the device is electrified.

⚠ The air filter for the QSW-7608 shall be cleaned periodically (generally once every three months) by dry cleaning or washing. Do not rub during the cleaning or washing and flat dry after the cleaning or washing.

Power Supply Maintenance

When the power supply fails, you only need to disconnect the power cable, loosen the two panel screws on the power module, unplug the power module, replace it with a good one, and tighten the panel screws, and then connect the power cables.

Replacing Fuses

To replace the old fuse wire with the correspondent new one, please contact the technical support representatives of QTECH. The following table lists the specifications for the module fuses.

Module	Fuse Slot Number	Fuse Specification
QSW-M7608-CM	F1	F 15A/65V
QSW-M7605-CM	F1	F 10A/125V
QSW-M7600-16SFP8XS-EA	F1	F 20A/125V
QSW-M7600-24SFP/12GT4XS-EA	F1	F 20A/125V
QSW-M7600-36GT12SFP4XS-EA	F1	F 20A/125V
QSW-M7600-48GT4XS-EA	F1	F 20A/125V
QSW-M7600-48GT4XS-P-EA	F1	F 20A/125V
QSW-M7600-48SFP4XS-EA	F1	F 20A/125V
QSW-M7600-24GT24SFP4XS-EA	F1	F 20A/125V
QSW-M08-FAN	F1	F 15A/65V

6 TROUBLESHOOTING

6.1 General Installation Troubleshooting Flow

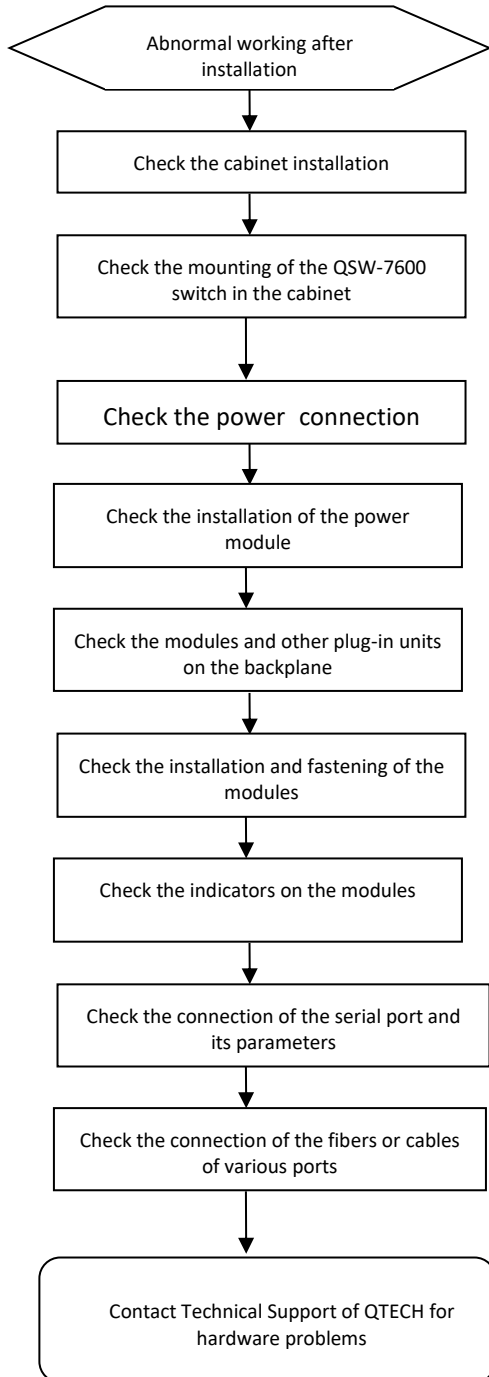

6.2 Common Troubleshooting Procedures

Fault 1: The AC power module does not work.

Fault Description:

The Status LED of each service module is OFF, the Power LED of the fan tray is OFF, and the fan does not work.

The LED on the panel of the power module is OFF. The fan does not work.

Troubleshooting:

First place the switches of all the power modules to OFF. Check if the cables of the cabinet have been correctly connected. Check whether the power cables are tightly connected to the cabinet power sockets and power modules. Check whether the power modules are installed correctly. If necessary, pull out the power modules and check whether the connectors on the backboard of the power system are tightened.

Fault 2: An exception occurs to the LEDs when service modules are powered on.

Fault Description:

The Status LED of the service module is OFF, blinking, or RED. The Link/ACT LED of the service module is solid ON when no network cable or fiber is plugged.

Troubleshooting:

Check if the service module is firmly inserted. If so, install the service module again and ensure that it is inserted into place before you tighten the fastening screws. If the service module still does not work, check if the connector of the slot on the backplane is loose. If yes, insert the service module to another slot for a try. If the slot and connection are not the cause, return the service module for repair.

Fault 3: The LED is abnormal after a service module works for some time.

Fault Description:

The Status LED of the service module is OFF or RED. The Link/ACT LED of the service module is solid ON when no network cable or fiber is plugged. The fault remains after restart.

Troubleshooting:

Check if the service module gets loose. If so, install the service module again and ensure that it is inserted into place before you tighten the fastening screws. If the module still does not work, check if the connector of the slot on the backplane is loose and check if the slide rail of the slot is deformed. If so, insert the service module to another slot for a try. If the slot and connection are not the cause, return the service module for repair.

Fault 4: The LED of the supervisor module is abnormal.

Fault Description:

The LED of the supervisor module becomes abnormal after the supervisor module is powered on or works for some time. For example, the Status LED is blinking or OFF, and the Alarm LED is red.

Troubleshooting:

Check if the supervisor module gets loose. If so, install the supervisor module again and ensure that it is inserted into place, before you tighten the fastening screws. If the supervisor module still does not work, check if the connector of the slot on the backplane is loose and check if the slide rail of the slot is deformed. If yes, insert the module to another slot for a try. If the slot and connection are not the cause, return the supervisor module for repair.

When the Alarm LED is red, the cause may be the fault of another module in the system, in which case you can check other modules (for example, service module, fan, power, and overheating) for any alarm. If yes, you should first handle the faults of other modules. You can also identify the faults by logging in to the management software.

Fault 5: The fan tray does not work or the LED is abnormal.**Fault Description:**

After the system starts, the fans in the fan tray do not work or the status LED is OFF.

Troubleshooting:

Check if the connection between the fan tray and the backplane is secure and if the connector gets loose. If the connection is secure, you need to replace the fan tray.

Fault 6: The serial port console has no output.**Fault Description:**

After the system is started, the serial port console does not display any information.

Troubleshooting:

Check whether serial port cables are connected correctly and whether the connected serial port is identical with that configured on the super terminal. Check whether the configuration of the serial port on the super terminal is the same as that described in *QSW-7600 Software Configuration Guide*. If not, modify the serial port configuration parameters. If there is still no serial port printed information, please contact QTECH Customer Service Department for technical support.

Fault 7: The serial port console outputs illegible characters.**Fault Description:**

The serial port console outputs illegible characters.

Troubleshooting:

Such problem is related to the settings of the serial port. Check if the settings of such parameters as the baud rate match those in *QSW-7608 series Software Configuration Guide*.

Fault 8: The newly-inserted service module fails to be powered on.**Fault Description:**

The system is running, yet all LEDs on the panel of the newly-inserted service modules are OFF, and the port is faulty.

Troubleshooting:

Check whether the service module is connected correctly and whether the summary power of the newly-inserted service module and other modules in the system exceeds the maximum power. If so, please add more power modules to provide the enough power for the power supply. If all checkings are OK, but the newly-inserted service module still cannot be powered on, please contact QTECH Customer Service Department for technical support.

Fault 9: The link cannot be set up between fiber interfaces

Fault Description:

The system runs normally. After the fiber interface is inserted into the optical module and the optical fiber is properly connected, the link cannot be set up.

Troubleshooting:

First confirm whether the interface is a copper/fiber combo interface. If yes, it should be configured in fiber mode. Then, do as follows:

1. Check whether the receiving and sending ends are wrongly connected. The sending end of the fiber interface needs to be connected to the receiving end of the other fiber interface. You can check by changing the sequence in which the two optical fibers are connected on the optical module.
2. Check whether the optical module wavelength of the two sides are consistent. For example, an optical module of 1310nm wavelength cannot be connected to an optical module of 1550nm wavelength.
3. Check whether the distance between the two sides exceeds the length indicated on the optical module.
4. Check whether the rates of the two sides match and whether the optical fiber type meets requirements. In addition, for ports supporting different rates, check whether rate modes are configured correctly.

 If above mentioned methods do not take effect, please contact QTECH for technology assistance.

7 REPLACING MODULES

7.1 Removing, Cleaning and Installing Air Filter

⚠ After the air filter is used for a long time, the dust may block the holes on the air filter, affecting heat dissipation and ventilation. It is recommended that the air filter be cleaned every three months.

7.1.1 Removing, Cleaning and Installing Air Filters for Supervisor and Service Modules

- ❖ Install the air filter of QSW-7608 supervisor and service modules:
 1. Insert the air filter along the slide rail. Pay attention to the direction instruction on the air filter.
 2. Tighten the screws on the air filter with a screwdriver.
- ❖ Remove the air filter of QSW-7608 supervisor and service modules:
 1. Loosen the captive screws on the air filter.
 2. Remove the air filter.
 - 3.
 4. Figure 7-1 Installing and Removing the Air Filter of QSW-7608 Supervisor and Service Modules

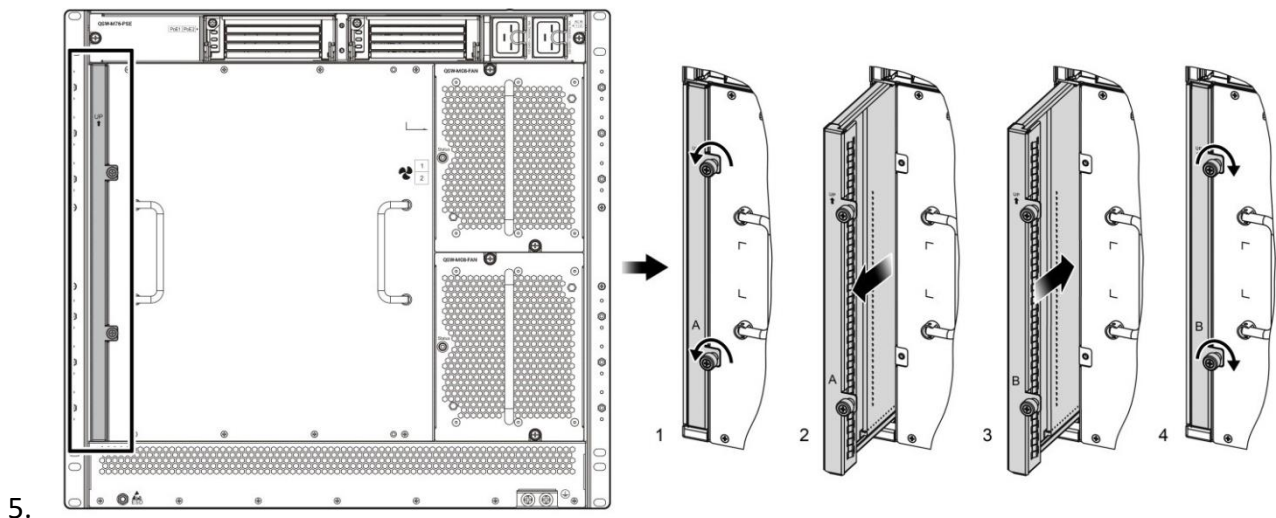

5.		
Note	A: Air filters to be removed	B: Air filters to be installed

7.2 Removing Swappable Interface Modules (Optional)

7.2.1 Removing SFP+/SFP Modules

Take the following steps to remove SFP/SFP+ modules:

1. Unplug the optical fiber.

2. Turn down the handle of the module until it is horizontal. Pull the tab to take out the SFP/SFP+ module, as shown in figure 7-2.
3. Figure 7-2 Removing the SFP/SFP+ Module

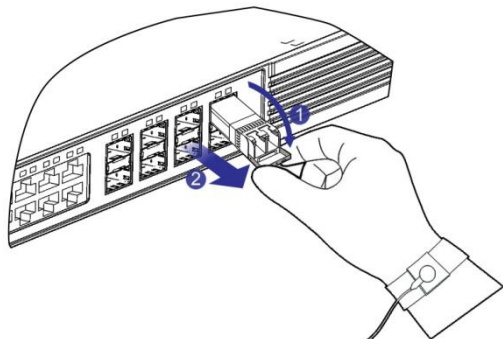

Precaution

- ❖ Unplug the optical fiber before removing the module.
- ❖ Do not pull out the module forcefully without turning down the handle of the module.
- ❖ Immediately install the dust plug to the module port and the switch fiber port.

7.2.2 Removing SFP+ Cables

Pull the tap out and unlock the module. Take out the SFP+ module gently, as shown in figure 7-3

Figure 7-3 Removing the SFP+ Cable

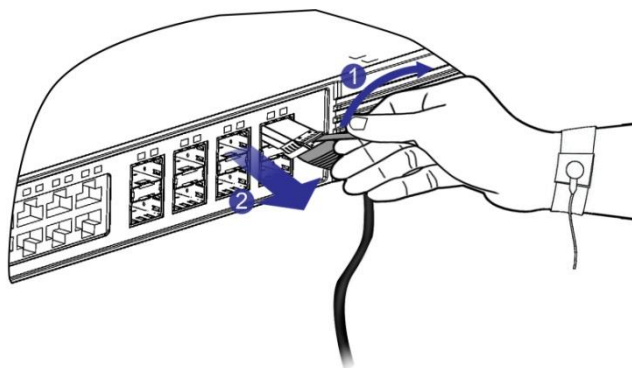

Precaution

- ❖ Pull the tab out before unplugging the cables. Otherwise, the module or the slot can be damaged.
- ❖ Immediately install the dust plug to the module port and the switch fiber port.

7.3 Replacing Modules

Preparation

1. Wear an anti-static wrist strap close to your skin and have it properly grounded.
2. Take out the module from the package.
3. Take the following steps to replace the module:

4. Unplug all cables/fibers such as fibers and RJ45 twisted pairs from the panel.
5. Hold down self-locking lever buttons on both sides of the panel and pull out the lever.
6. Drag the lever to pull the module out, Before the module is about to be removed from the chassis, support the bottom of the module with one hand and hold the module with the other hand, so as to prevent the module from falling.
7. Pull out the levers on both sides of the module. Support the bottom of the module with one hand and hold the module with the other hand to insert the module into the slot along the rail.
8. Drive the levers close to the module, and the module will hit the back panel. The module will be fastened after self-locking of levers.
9. Figure 7-4 Replacing the Module (for QSW-7608)

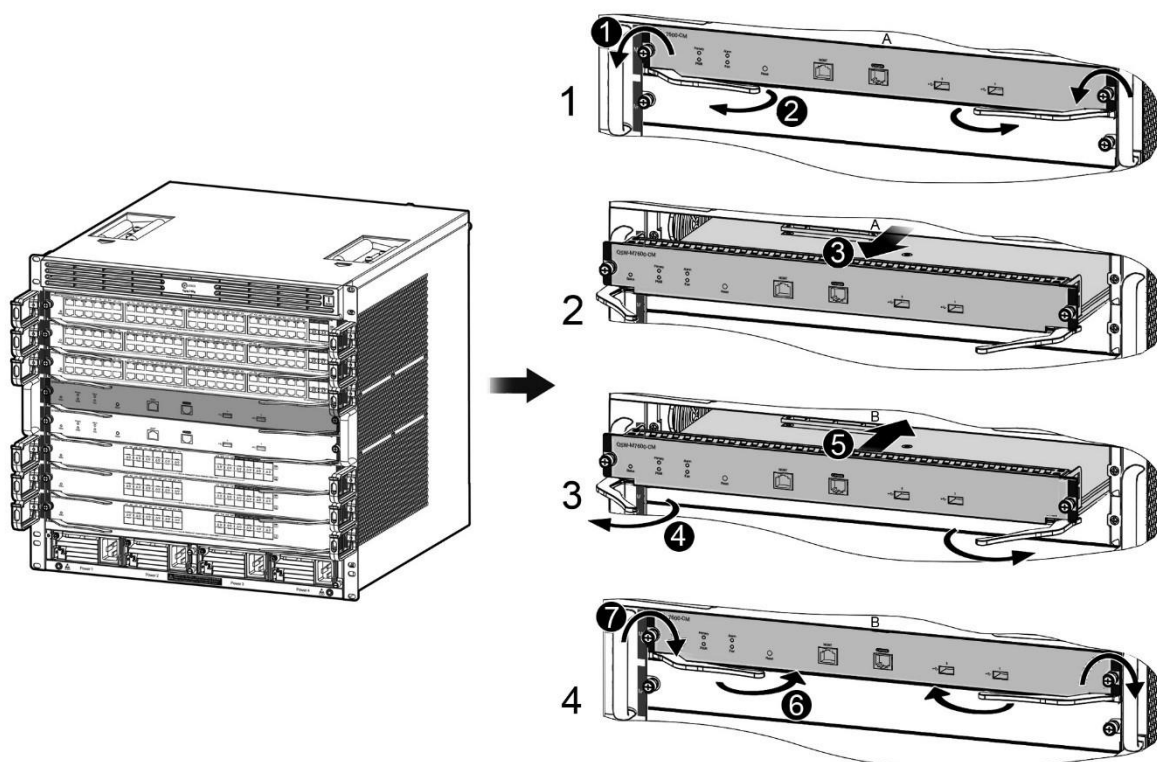
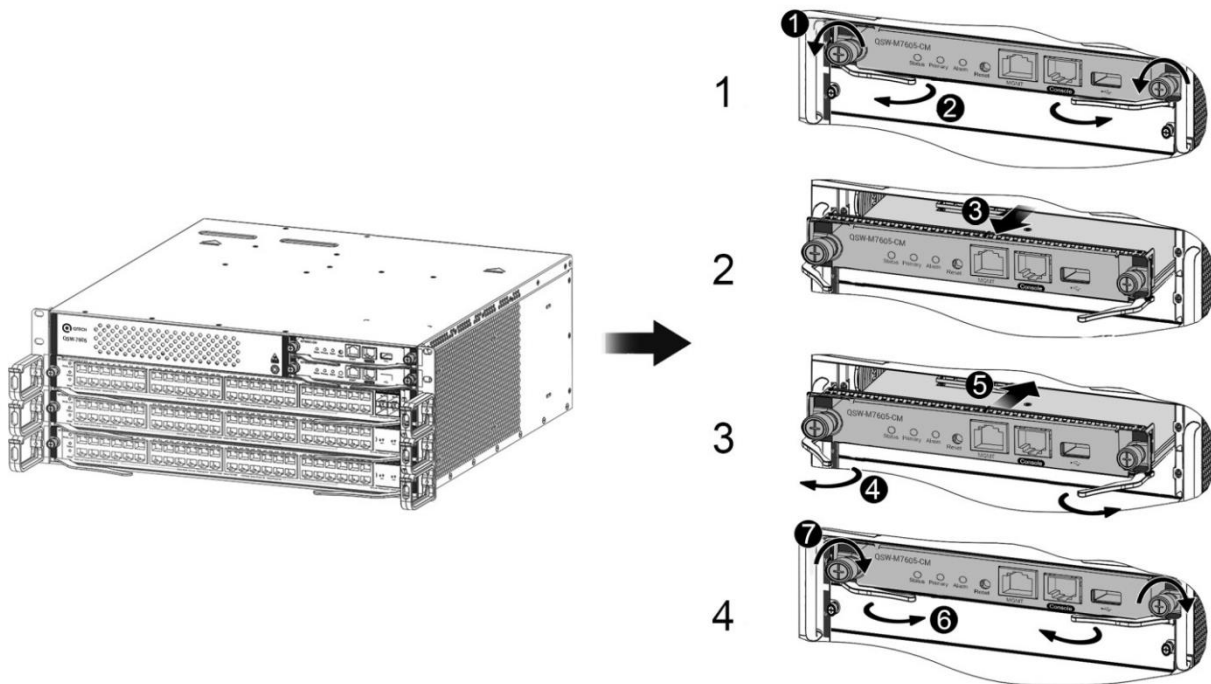

Figure 7-5 Replacing the Module (for QSW-7605)



- ⚠ In order to ensure the reliability of the system ventilation and heat dissipation performance and address the requirement of the dust-filter, filler panel needs to be installed in the slot where no supervisor module or service module has been installed.
- ⚠ If you want to remove the module when the device is electrified, you need to insert the new module or install the filler panel within 10 minutes.
- ⚠ Do not hold the edge of the PCB or collide the components on the PCB
- ⚠ Do not plug/unplug a supervisor module or service module forcedly, use the ejector.

7.4 Removing Power Modules

Preparation

1. Wear an anti-static wrist strap close to your skin and have it properly grounded.
2. Take out the power module from the package.
3. Please power off the module before removing it.

- ⚠ After hot swapping a module, please wait for at least 30 seconds for the next operation.
- ⚠ Before inserting or removing the power module, please verify whether the switch is well mounted. Prevent the switch from tumbling down when you are inserting or removing the power module.
- ⚠ Do not touch the connecting finger on the power module which has been removed to avoid being electrocuted in case of incomplete discharge.

Take the following steps to remove the power module on QSW-7608:

1. Unplug the cable. Separate the pigtail plug of the cable from the connector of the power module.

2. Unloosen the captive screws on the power module with the screwdriver.
3. Pull out the handle to make it vertical from the power panel.
4. Drag the power module panel with one hand and support the bottom of the power module with the other hand to pull out the power module.
5. Insert the power module into the slot until it hits the back panel.
6. Drive the handle close to the panel.
7. Tighten the captive screws on the panel with the screwdriver.

Figure 7-6 Removing the Power Module on QSW-7608

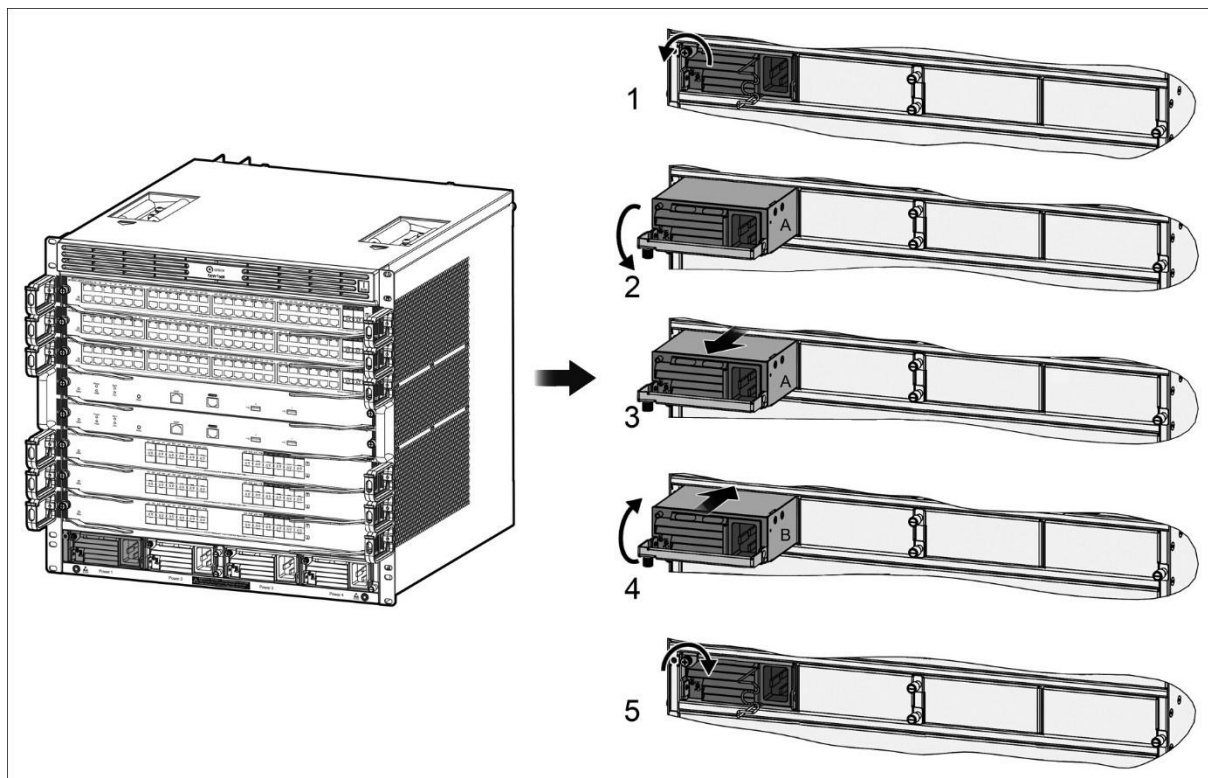

Note:	A: Power modules to be removed	B: Power module to be installed
-------	--------------------------------	---------------------------------

Take the following steps to remove the power module on QSW-7605:

1. Unplug the cable. Separate the pigtail plug of the cable from the connector of the power module.
2. Press the clip and pull out the power module.
3. Drag the power module panel with one hand and support the bottom of the power module with the other hand to pull out the power module.
4. Insert the power module into the slot until it clicks into place.

Figure 7-7 Removing the Power Module on QSW-7605

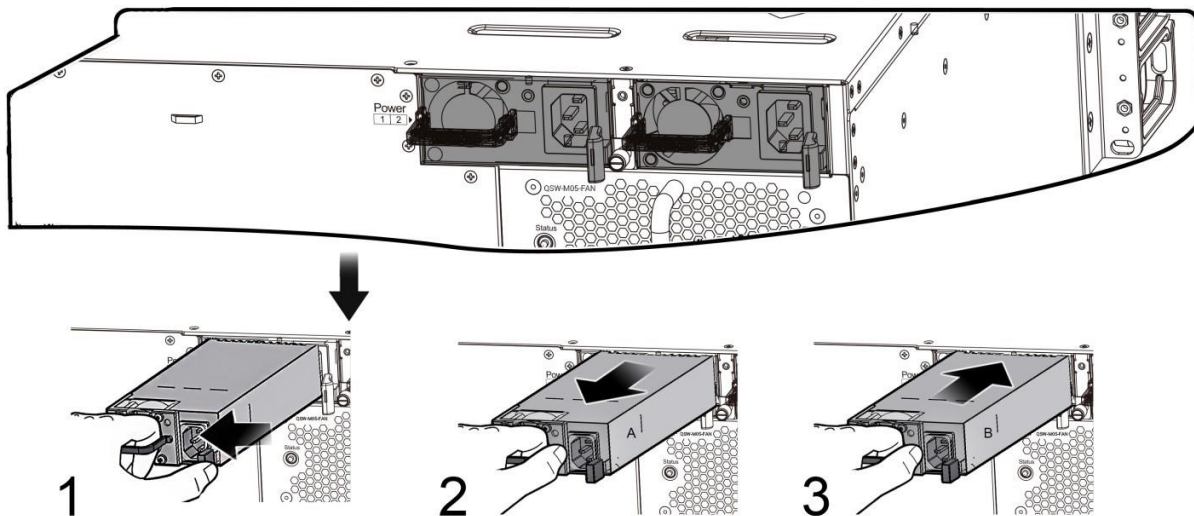

Note:	A: Power modules to be removed	B: Power module to be installed
-------	--------------------------------	---------------------------------

7.5 Removing Fans

- ⚠ Do not touch any bare wire, terminal or the power instruction on the switch.
- ⚠ The fan tray supports hot swapping, If you want to remove the fan tray when the switch is operational, do not remove the fan tray until the fan stops rotating, Besides, do not put your hands inside the fan tray.
- ⚠ If you remove the fan tray when the switch is operational, install another fan tray quickly to ensure normal operation of the switch and avoid damage to the switch.

Preparation

1. Wear an anti-static wrist strap close to your skin and have it properly grounded.
2. Take out the fan module from the package.

Take the following steps to remove the fan module:

1. Unloosen the captive screws on the fan tray with the Phillips screwdriver.
2. Pull out the fan tray and put it in the anti-static bag.
3. Insert the fan tray into the slot along the slide rail until the fan tray hits the back panel.
4. Tighten the captive screws on the fan tray with the Phillips screwdriver.

Figure 7-8 Removing the Fan for QSW-7608

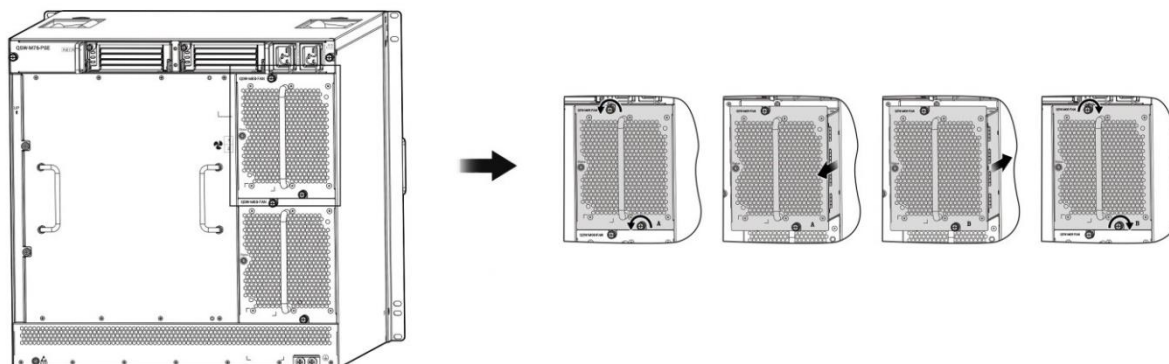
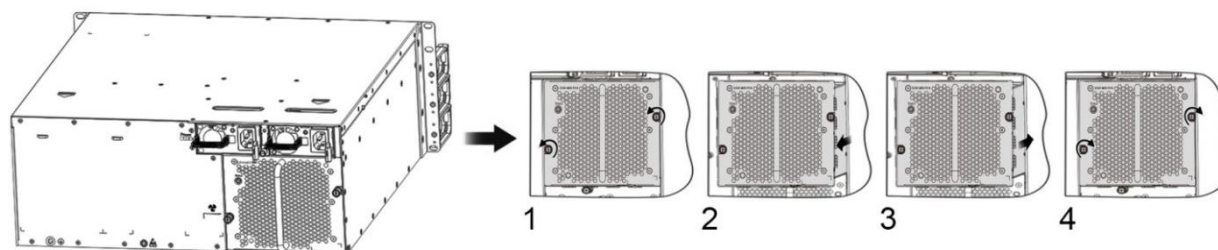

Figure 7-9 Removing the Fan for QSW-7605



7.6 Removing PoE Frame

- ⚠ Do not touch any bare wire, terminal or the power instruction on the switch.
- ⚠ The PoE frame does not support hot swapping. Do not remove the frame unless the switch is not electrified. Besides, do not put your hands inside the frame.

Preparation

1. Wear an anti-static wrist strap close to your skin and have it properly grounded.
2. Take out the PoE power frame from the package.

Take the following steps to remove the PoE frame:

1. Unloosen the captive screws on the frame with the Phillips screwdriver.
2. Pull out the frame and put it in the anti-static bag.
3. Insert the frame into the slot along the slide rail until it hits the back panel.
4. Tighten the captive screws on the frame with the Phillips screwdriver.

Figure 7-10 Removing the PoE power frame for QSW-7608

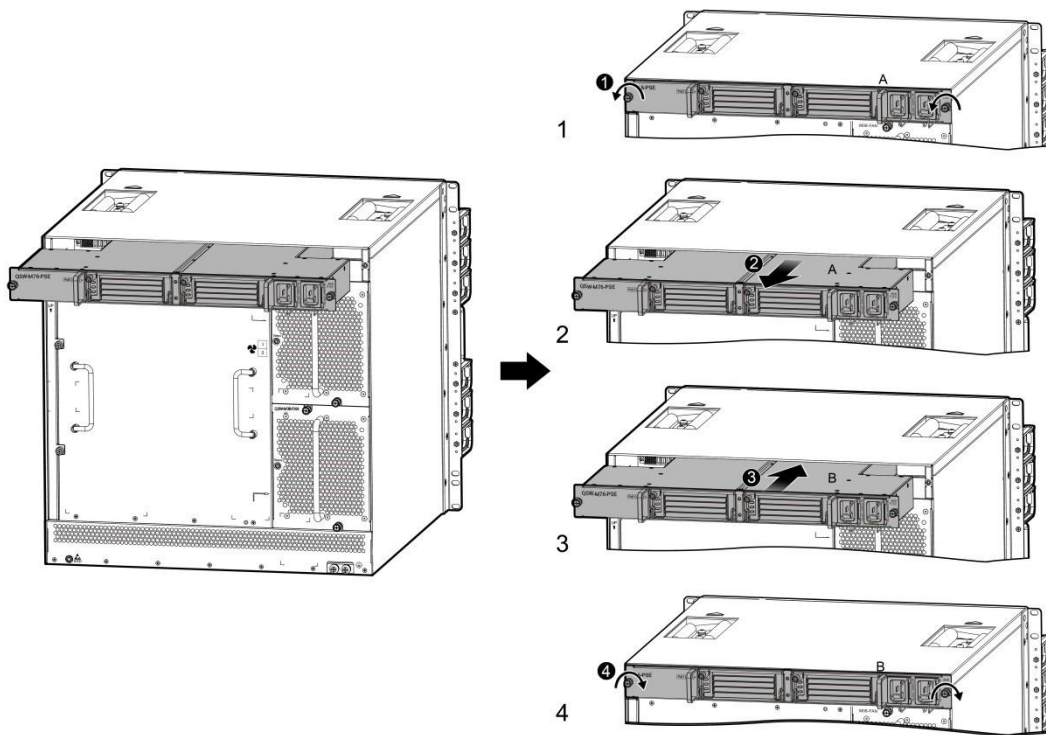

Note:

A: PoE power frame modules to be removed

B: PoE power frame modules to be installed

8 CABLES

i This chapter describes the precautions and simple steps for cable connection and bundling. See *Appendix C cabling Recommendations in Installation* for detailed cabling and bundling.

8.1 Connecting the External Port Cables

Precautions

- ❖ Correctly distinguish single-mode and multi-mode fibers and ports.
- ❖ Avoid bends of small radius at the connector.

Simple Connection Steps

1. Connect one end of the RJ45 connector for configuring Ethernet cables to the Ethernet interface of the device module and the other end to the NMS or a control terminal; or connect one end of the standard RJ45 serial port cable to the serial port of the device module and the other end to the NMS or a control terminal.
2. Insert the single-mode or multi-mode fiber into the appropriate interface according to the identification on the panel of the module. Distinguish the Rx/Tx end of the fiber.
3. Insert the twisted pair with the RJ45 port into the appropriate interface according to the identification on the panel of the module. Distinguish the crossover cable and straight-through cable.
4. Connect the cables and fibers of each module in sequence.

8.2 Bundling the Cables

Precautions

- ❖ The power cables and other cables should be bundled in a visually pleasing way.
- ❖ When you bundle fibers, make sure that the fibers at the connectors have natural bends or bends of large radius.
- ❖ Do not bundle fibers and twisted pairs too tightly, as this may press hard the fibers and affect their useful life and transmission performance.

Simple Bundling Steps

1. Bundle the drooping part of the fibers and twisted pairs of each module, and lead them to both sides of the chassis for convenience.
2. On the both sides of the chassis, fasten the fibers and twisted pairs to the cabinet cable management ring or bracket.
3. For the power cables, you should bundle them closely along the bottom of the chassis, in a straight line wherever possible.

9 APPENDIX A CONNECTORS AND MEDIA

1000BASE-T/100BASE-TX/10BASE-T

The 1000BASE-T/100BASE-TX/10BASE-T is a 10/100/1000 Mbps auto-negotiation port that supports auto MDI/MDIX.

Compliant with IEEE 802.3ab, 1000BASE-T requires Category 5e 100-ohm UTP or STP (STP is recommended) with a maximum distance of 100 meters (328 feet).

1000BASE-T requires all four pairs of wires be connected for data transmission, as shown in Figure A-1

Figure A-1 1000BASE-T Connection

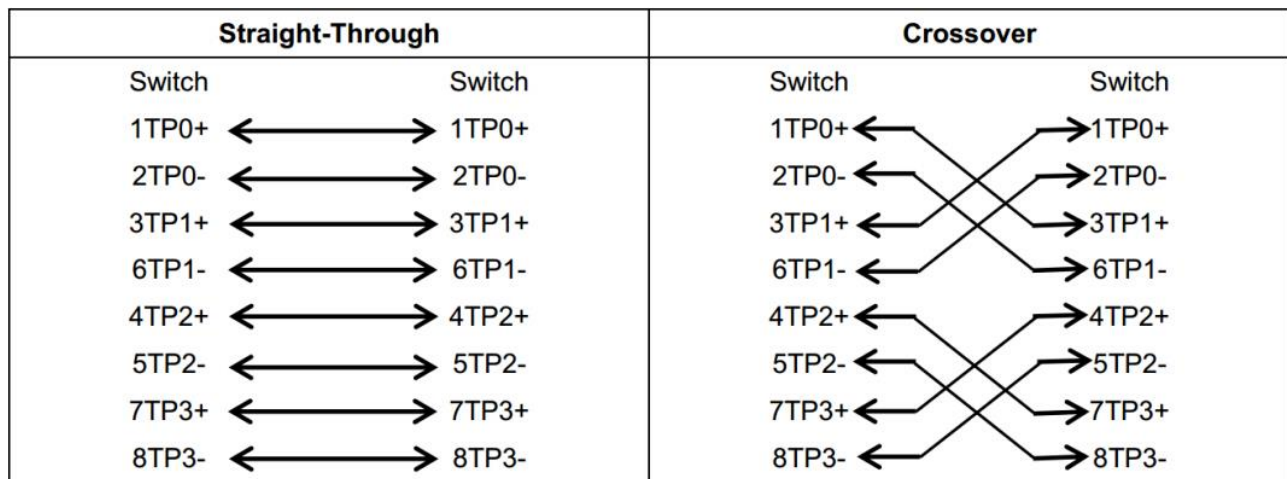

10BASE-T uses Category 3, 4, 5 100-ohm UTP/STP and 1000BASE-T uses Category 5 100-ohm UTP/STP for connections. Both support a maximum length of 100 meters. Figure A-2 shows 100BASE-TX/10BASE-T pin assignments.

Figure A-2 100BASE-TX/10BASE-T Pin Assignments.

Pin	Socket	Plug
1	Input Receive Data+	Output Transmit Data+
2	Input Receive Data-	Output Transmit Data-
3	Output Transmit Data+	Input Receive Data+
6	Output Transmit Data-	Input Receive Data-
4,5,7,8	Not used	Not used

Figure A-3 shows wiring of straight-through and crossover cables for 100BASE-TX/10BASE-T.

Figure A-3 100BASE-TX/10BASE-T Connection

Straight-Through		Crossover	
Switch	Adapter	Switch	Switch
1 IRD+	1 OTD+	1 IRD+	1 IRD+
2 IRD-	2 OTD-	2 IRD-	2 IRD-
3 OTD+	3 IRD+	3 OTD+	3 OTD+
6 OTD-	6 IRD-	6 OTD-	6 OTD-

Fiber Connection

You can choose to use single mode or multimode fibers according to the transceiver module types. Figure A-4 shows connection of fiber cables.

Figure A-4 Fiber Connection

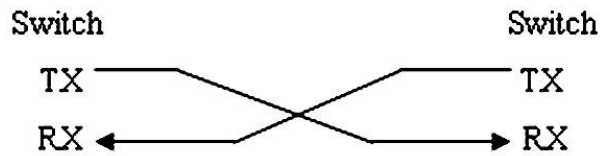

10 APPENDIX B SWITCH LIGHTNING PROTECTION

Installing AC Power Arrester (lightning protection cable row)

The external lightning protection cable row shall be used on the AC power port to prevent the switch from being struck by lightning when the AC power cable is introduced from the outdoor and directly connected to the power port of the switch. The lightning protection cable row is fixed on the cabinet, operating table or the wall in the machine room using the line buttons and screws.

Figure B-1 Schematic Diagram for the Power Arrester

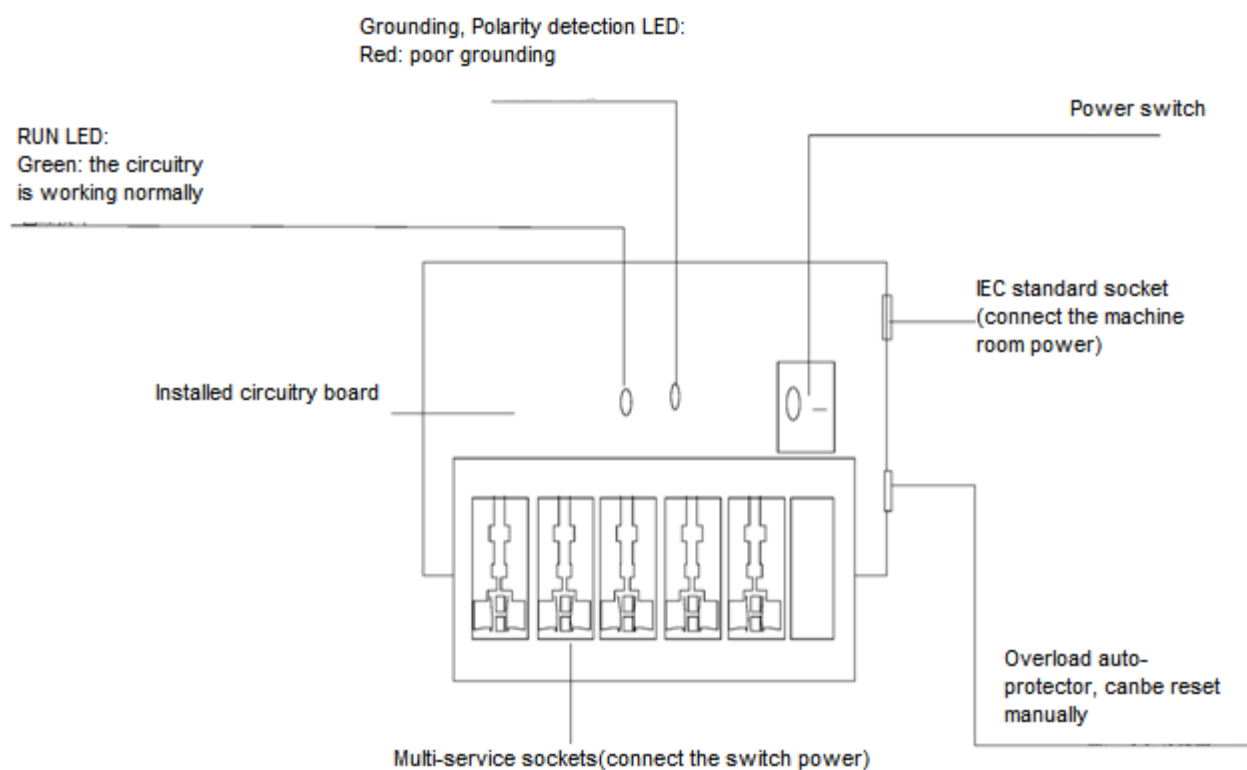

The power arrester is not provided and the user shall purchase it to address the practical requirement.

Precautions for installation:

- ❖ Make sure that the PE terminal of the power arrester has been well-grounded;
- ❖ After connecting the switch AC power plug to the socket of the power arrester (lightning protection socket), lightning protection function implements if the RUN LED is Green and the ALARM LED is OFF.
- ❖ If the ALARM LED on the power arrester is Red, you shall check what the reason is, poor grounding connection or the reversed connection of the Null and Live lines: Use the multimeter to check the polarity of the power socket for the arrester when the LED is Red, if the N line is on the left and the L line is on the right, the arrester PE terminal is not grounded; if the L line is on the left and the N line is on the right, the polarity of the

arrester power cable shall be reversed; if the LED is still Red, it is confirmed that the arrester PE terminal has not been grounded.

Installing the Ethernet Port Arrester

During the switch usage, the Ethernet port arrester shall be connected to the switch to prevent the switch damage by lightning before the outdoor network cable connects to the switch.

Tools: Cross or straight screwdriver, Multimeter, Diagonal pliers

Installation Steps:

1. Tear one side of the protection paper for the double-sided adhesive tape and paste the tape to the framework of the Ethernet port arrester. Tear the other side of the protection paper for the double-sided adhesive tape and paste the Ethernet port arrester to the switch framework. The paste location for the Ethernet port arrester shall be as close to the grounding terminal of the switch.
2. Based on the distance of the switch grounding terminal, cut the grounding line for the Ethernet port arrester and firmly tighten the grounding line to the grounding terminal of the switch.
3. Use the multimeter to check whether the grounding line for the arrester is in good contact with the switch grounding terminal and the framework.
4. According to the description on the Ethernet Port Arrester Hardware Installation Guide, connect the arrester using the adapter cable (note that the external network cable is connected to the end of IN, while the adapter cable connected to the switch is connected to the end of OUT) and observe whether the LED on the board is normal or not.
5. Use the nylon button to bundle the power cables.

Figure B-2 Schematic Diagram for the Ethernet port Arrester Installation

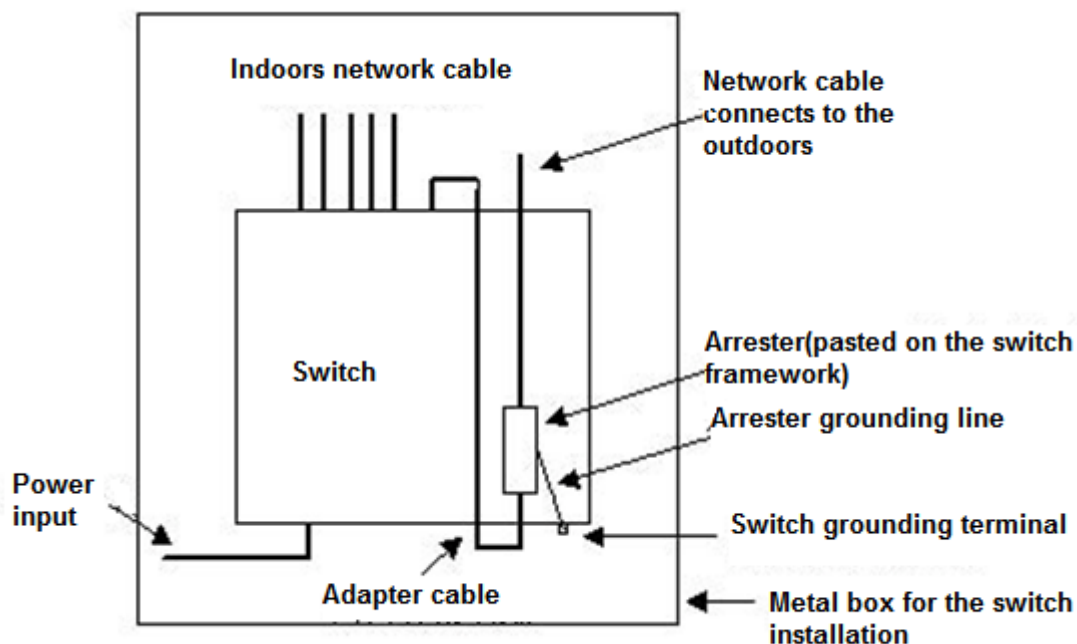

The Ethernet port arrester is only for the 10M/100M copper Ethernet ports with the RJ-45 connector;

The Ethernet port arrester is not provided, the user can purchase them to address their own practical requirements. For the detailed information during the arrester installation, please refer to Ethernet Port Arrester Hardware Installation Guide, which contains the technical specification and the maintenance and installation of the arrester.

You may pay attention to the following conditions during the actual installation to avoid influencing the performance of the Ethernet port arrester:

- ❖ Reversed direction of the arrester installation. You shall connect the external network cable to the “IN” end and connect the switch Ethernet port to the “OUT” end.
- ❖ Poor arrester grounding. The length of the grounding line should be as short as possible to ensure that it is in good contact with the switch grounding terminal. Use the multimeter to confirm the contact condition after the grounding.
- ❖ Incomplete arrester installation. If there is more than one port connected to the peer device on the switch, it needs to install the arresters on all connection ports for the purpose of the lightning protection.

11 APPENDIX C CABLING RECOMMENDATIONS IN INSTALLATION

When QSW-7608 series switches are installed in standard 19-inch cabinets, route cable bundles upward or downward along the sides of the rack depending on the actual situation in the equipment room. All cable connectors should be placed at the bottom of the cabinet rather than be exposed outside of the cabinet. Power cords should be routed upward or downward beside the cabinet close to the location of the DC power distribution cabinet, AC power outlet, or lightning protection box.

Required Minimum Cable Bend Radius

- ❖ The minimum bend radius of a power, communication or flat cable should be 5 times the overall diameter of the cable. If the cable is constantly bent, plugged or unplugged, the bend radius should be 7 times the overall diameter.
- ❖ The minimum bend radius of a coaxial cable should be 7 times the overall diameter of the cable. If the cable is constantly bent, plugged or unplugged, the bend radius should be 10 times the overall diameter.
- ❖ The minimum bend radius of a high-speed cable, such as an SFP+ cable should be 5 times the overall diameter of the cable. If the cable is constantly bent, plugged or unplugged, the bend radius should be 10 times the overall diameter. Required minimum fiber bend radius
- ❖ The diameter of a fiber tray to hold fibers cannot be less than 25 times the diameter of the fiber.
- ❖ When moving an optical fiber, the bend radius of the fiber should be equal to or greater than 20 times the diameter of the fiber.
- ❖ During cabling of an optical fiber, the bend radius of the fiber should be equal to or greater than 10 times the diameter of the fiber.

Precautions for Cable Bundling

- ❖ Before bundling cables, correctly mark labels and stick the labels to cables where appropriate.
- ❖ Cables should be neatly and properly bundled, as shown in Figure C-1.

Figure C-1 Bundling Cables

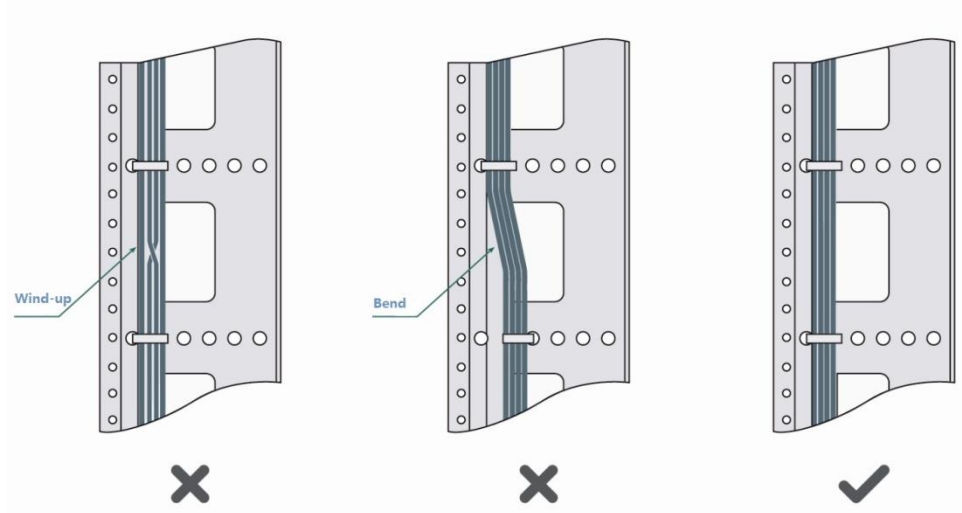

- ❖ Route and bundle power, signal, ground cables separately. When the cables are close to each other, cross them. When power cables run parallel to signal cables, the distance between them must be b
- ❖ All cable trays and their accessories shall be smooth and free from sharp edges.
- ❖ Holes in metal, through which cables pass shall have smooth, well-rounded surfaces or be protected with insulating bushings.
- ❖ Use proper cable ties to bind cables together. Do not tie two or more cable ties to bind cables.
- ❖ Cut off excess cable tie cleanly with no sharp edges after bundling cables, as shown in Figure C-2.

Figure C-2 Cutting off Excess Cable Tie

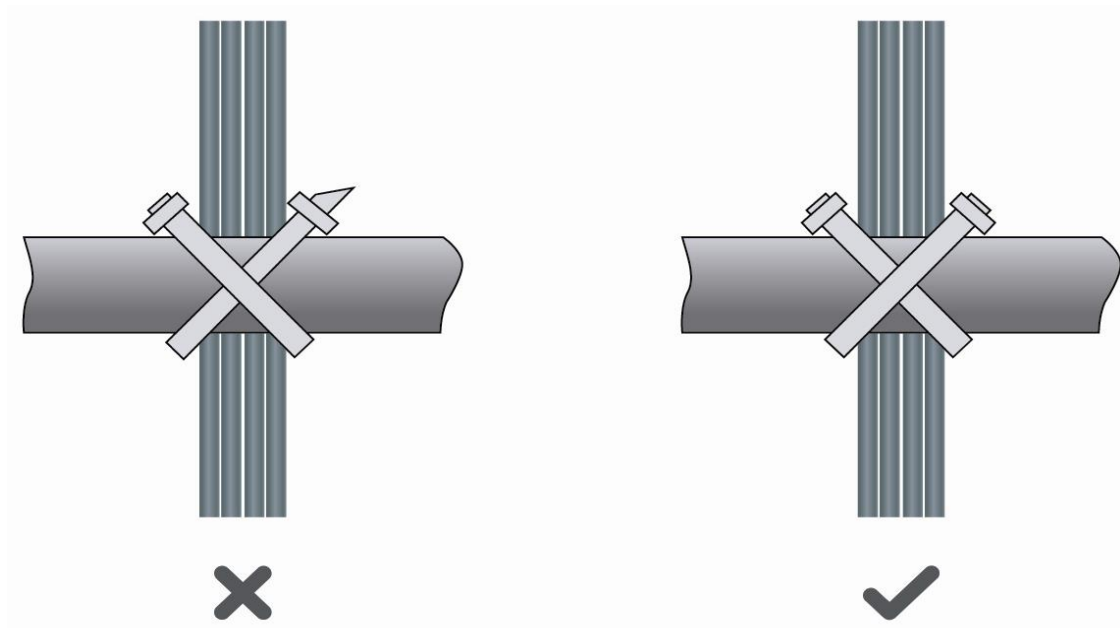

- ❖ If cables are to be bent, bind them first but do not tie cable ties within the bend to avoid stress on the cables, which may otherwise cause the wires inside to break, as shown in Figure C-3.

Figure C-3 Do Not Tie Cable Ties within the Bend

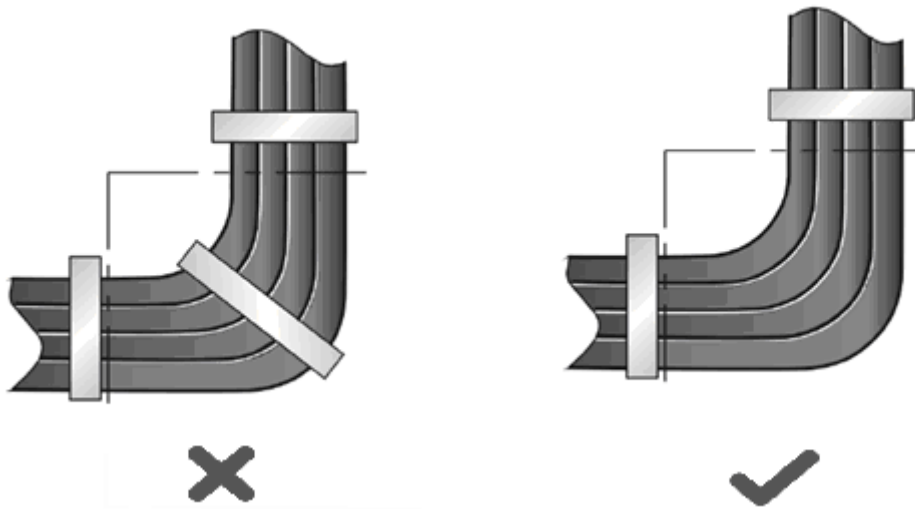

- ❖ Wrap up unnecessary or excess cables and bind them to the appropriate rack position, where device operation is not affected and no damages occur to the device and cables during debugging.
- ❖ Do not bind power cords to the rails for moving parts.
- ❖ Leave a certain length of the cable connecting moving parts, such as the ground wire of the cabinet door, to avoid stress on the cable; When moving parts are in place, ensure the excess cable length shall not contact heat sources, sharp corners or edges. If heat sources are unavoidable, use high-temperature cables instead.
- ❖ When using screws to fasten cable lugs, the bolts or nuts shall be tightened and prevented from loosening, as shown in Figure C-4.

Figure C-4 Fastening Cable Lugs

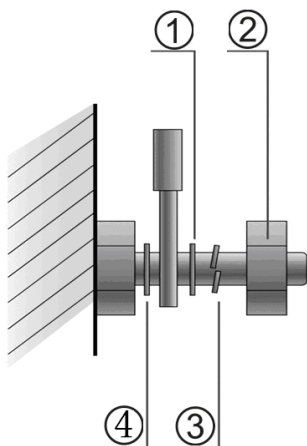

Note	1. Flat washer 2. Nut	3. Spring washer 4. Flat washer
------	--------------------------	------------------------------------

- ❖ When using a stiff cable, fix it near the cable lug to avoid stress on the lug and cable.
- ❖ Do not use self-tapping screws to fasten terminals.
- ❖ Bundle cables of the same type and running in the same direction into groups. Keep cables clean and straight.
- ❖ Cables shall be tied according to the following table.

Diameter of Cable Bundle (mm)	Space between Bundles (mm)
10	80 to 150
10 to 30	150 to 200
30	200 to 300

- ❖ Do not tie knots for cables or cable bundles.
- ❖ The metal parts of the cold-pressed terminal blocks, such as air circuit breakers, shall not be exposed outside of the blocks.

12 APPENDIX D SITE SELECTION

- ❖ The machine room should be at least 5km away from the heavy pollution source such as the smelter, coal mine and thermal power plant, 3.7km away from the medium pollution source such as the chemical industry, rubber industry and electroplating industry, and 2km away from the light pollution source such as the food manufacturer and leather plant. If the pollution source is unavoidable, the machine room should be located on the windward side of the pollution source perennially with advanced protection.
- ❖ The machine room should be at least 3.7km away from the sea or salt lake. Otherwise, the machine room must be sealed, with air conditioner installed for temperature control. Saline soil cannot be used for construction. Otherwise, you should select devices with advanced protection against severe environment.
- ❖ Do not build the machine room in the proximity of livestock farms. Otherwise, the machine room should be located on the windward side of the pollution source perennially. The previous livestock house or fertilizer warehouse cannot be used as the machine room.
- ❖ The machine room should be firm enough to withstand severe weather conditions such as windstorm and heavy rain as well as away from dust. If the dust is unavoidable, keep the door and window away from the pollution source.
- ❖ The machine room should be away from the residential area. Otherwise, the machine room should meet the construction standard in terms of noise.
- ❖ Make sure the air vent of the machine room is away from the sewage pipe, septic tank, and sewage treatment tank. Keep the machine room under positive pressure to prevent corrosive gas from entering the machine room to corrode components and circuit boards. Keep the machine room away from industrial boiler and heating boiler.
- ❖ The machine room had better be on the second floor or above. Otherwise, the machine room floor should be 600mm higher than the highest flood level ever recorded.
- ❖ Make sure there are no cracks or holes in the wall and floor. If there are cable entries in the wall or window, take proper sealing measures. Ensure that the wall is flat, wear-resistant, and dust-free, which should be up to the standard for flame retarding, soundproofing, heat absorption, dust reduction, and electromagnetic shielding.
- ❖ Keep the door and the window closed to make the machine room sealed.
- ❖ The steel door is recommended for soundproofing.
- ❖ Sulfur-containing materials are forbidden.
- ❖ Pay attention to the location of the air conditioner. Keep the air conditioner from blowing wind straight toward the device or blowing water drops from the window or air vent toward the device.