

Flow Monitor Configuration

Оглавление

1. MIRROR CONFIGURATION	3
1.1. Introduction to Mirror	3
1.2. Mirror Configuration Task List	3
1.3. Mirror Examples	4
1.4. Device Mirror Troubleshooting	5
2. RSPAN CONFIGURATION	6
2.1. Introduction to RSPAN	6
2.2. RSPAN Configuration Task List	8
2.3. Typical Examples of RSPAN	9
2.4. RSPAN Troubleshooting	12
3. ERSPAN	14
3.1. Introduction to ERSPAN	14
3.2. ERSPAN Configuration Task List	14
3.3. Typical Examples of ERSPAN	15
3.4. ERSPAN Troubleshooting	17

1. MIRROR CONFIGURATION

1.1. Introduction to Mirror

Mirror functions include port mirror function, CPU mirror function, flow mirror function.

Port mirror refers to the duplication of data frames sent/received on a port to another port. The duplicated port is referred to as mirror source port and the duplicating port is referred to as mirror destination port. A protocol analyzer (such as Sniffer) or a RMON monitor will be connected at mirror destination port to monitor and manage the network, and diagnose the problems in the network.

CPU mirror function means that the switch exactly copies the data frames received or sent by the CPU to a port.

Flow mirror function means that the switch exactly copies the data frames received or by the specified rule of a port to another port. The flow mirror will take effect only the specified rule is permit.

A chassis switch supports at most 4 mirror destination ports, each boardcard allows a source or destination port of a mirror session. At present, each box switch can set many mirror sessions. There is no limitation on mirror source ports, one port or several ports is allowed. When there are more than one source ports, they can be in the same VLAN or in different VLAN. The source port and destination port can be in different VLAN.

Notice: box switch can't use CPU's rx mirror and port's tx mirror at the same time.

1.2. Mirror Configuration Task List

1. Specify mirror destination port
2. Specify mirror source port (CPU)
3. Specify flow mirror source

1. Specify mirror destination port

Command	Explanation
Global mode	
<pre>monitor session <session> destination interface <interface- number> no monitor session <session> destination interface <interface- number></pre>	Specifies mirror destination port; the no command deletes mirror destination source port.

2. Specify mirror source port (CPU)

Command	Explanation
Global mode	
<pre>monitor session <session> source {interface <interface-list> cpu [slot <slotnum>]} {rx tx both} no monitor session <session> source {interface <interface- list> cpu [slot <slotnum>]}</pre>	Specifies mirror source port; the no command deletes mirror source port.

3. Specify flow mirror source

Command	Explanation
Global mode	
<pre>monitor session <session> source {interface <interface-list>} access- group <num> {rx tx both} no monitor session <session> source {interface <interface-list>} access- group <num></pre>	Specifies flow mirror source port and apply rule; the no command deletes flow mirror source port.

1.3. Mirror Examples

1. Example:

The requirement of the configurations is shown as below: to monitor at interface 1 the data frames sent out by interface 9 and received from interface 7, sent and received by CPU, and the data frames received by interface 15 and matched by rule 120(The source IP address is 1.2.3.4 and the destination IP address is 5.6.7.8).

Configuration guidelines:

1. Configure interface 1 to be a mirror destination interface.
2. Configure the interface 7 ingress and interface 9 egress to be mirrored source.
3. Configure the CPU as one of the source.
4. Configure access list 120.
5. Configure access 120 to binding interface 15 ingress.

Configuration procedure is as follows:

```
Switch(config)#monitor session 4 destination interface ethernet 1/0/1
Switch(config)#monitor session 4 source interface ethernet 1/0/7 rx
Switch(config)#monitor session 4 source interface ethernet 1/0/9 tx
Switch(config)#monitor session 4 source cpu
Switch(config)#access-list 120 permit tcp 1.2.3.4 0.0.0.255 5.6.7.8
0.0.0.255
Switch(config)#monitor session 4 source interface ethernet 1/0/15 access-
list 120 rx
```

1.4. Device Mirror Troubleshooting

If problems occur on configuring port mirroring, please check the following first for causes:

- Whether the mirror destination port is a member of a TRUNK group or not, if yes, modify the TRUNK group.
- If the throughput of mirror destination port is smaller than the total throughput of mirror source port(s), the destination port will not be able to duplicate all source port traffic; please decrease the number of source ports, duplicate traffic for one direction only or choose a port with greater throughput as the destination port. Mirror destination port can not be pulled into Isolate vlan, or will affect mirror between VLAN.
- When sending unknown unicast, broadcast and multicast data, it is recommended to set only one session for egress mirror.

2. RSPAN CONFIGURATION

2.1. Introduction to RSPAN

Port mirroring refers to the duplication of data frames sent/received on a port to another port. The duplicated port is referred to as mirror source port and the duplicating port is referred to as mirror destination port. It is more convenience for network administrator to monitor and manage the network and diagnostic after the mirroring function achieved. But it only used for such instance that the mirror source port and the mirror destination ports are located in the same switch.

RSPAN (remote switched port analyzer) refers to remote port mirroring. It eliminates the limitation that the source port and the destination port must be located on the same switch. This feature makes it possible for the source port and the destination port to be located on different devices in the network, and facilitates the network administrator to manage remote switches. It can't forward traffic flows on remote mirror VLAN.

There are three types of switches with the RSPAN enabled:

1. Source switch: The switch to which the monitored port belongs. The source switch copies the mirrored traffic flows to the Remote VLAN, and then through Layer 2 forwarding, the mirrored flows are sent to an intermediate switch or destination switch.
2. Intermediate switch: Switches between the source switch and destination switch on the network. Intermediate switch forwards mirrored flows to the next intermediate switch or the destination switch. Circumstances can occur where no intermediate switch is present, if a direct connection exists between the source and destination switches.
3. Destination switch: The switch to which the destination port for remote mirroring belongs. It forwards mirrored flows it received from the Remote VLAN to the monitoring device through the destination port.

When configuring the RSPAN mirroring of the source switch, reflector port mode or destination mirror port mode can be selected. The destination switch will redirect all the data frames in the RSPAN VLAN to the RSPAN destination port. For RSPAN mirroring, normal mode and advanced mode can be chosen, normal is introduced by default and fit the normal user. The advanced mode fit the advanced user.

1. Advanced mode: To redirect data frames in RSPAN VLAN to the RSPAN destination port, the intermediary and destination devices should support the redirection of flow.
2. Normal mode: To configure the RSPAN destination port in the RSPAN VLAN. Thus, datagrams in the RSPAN VLAN will be broadcasted to the destination port. In this mode, the destination port should be in RSPAN VLAN, and the source port should not be configured for broadcasting storm control. TRUNK ports should be configured carefully in order not to forward RSPAN datagrams to external networks. The normal mode has the benefit of easy configuration, and reduced system resources.

To be noticed: Normal mode is introduced by default. When using the normal mode, datagrams with reserved MAC addresses cannot be broadcasted.

For chassis switches, at most 4 mirror destination ports are supported, and source or destination port of one mirror session can be configured on each line card. For box switches, only one mirror session can be configured. The number of the source mirror ports is not limited, and can be one or more. Multiple source ports are not restricted to be in the same VLAN. The destination port and the source ports can be in different VLAN.

For configuration of RSPAN, a dedicated RSPAN VLAN should be configured first for carrying the RSPAN datagrams. The default VLAN, dynamic VLAN, private VLAN, multicast VLAN, and the layer 3 interface enabled VLAN cannot be configured as the RSPAN VLAN. The reflector port must belong to the RSPAN VLAN. The destination port should be connected to the Monitor and the configured as access port or the TRUNK port. The RSPAN reflector port will be working dedicatedly for mirroring, when a port is configured as a reflector port, it will discards all the existing connections to the remote peer, disable configurations related to loopback interfaces, and stop forwarding datagram. Connectivity between the source and destination switch for Remote VLAN, should be made sure by configuration.

To be noticed:

1. Layer 3 interfaces related to RSPAN VLAN should not be configured on the source, intermediate, and the destination switches, or the mirrored datagrams may be discarded.
2. For the source and intermediate switches in the RSPAN connections, the native VLAN of TRUNK port cannot be configured as the RSPAN VLAN, Otherwise the RSPAN tag will be disposed before reaching the destination switches.
3. The source port, in access or trunk mode, should not be added to RSPAN VLAN if advanced RSPAN mode is chosen. When the reflector port is used for a inter-card mirroring of CPU TX data, it must be configured as TRUNK port and allows the RSPAN VLAN data passing, the Native VLAN should not be configured as RSPAN VLAN.
4. When configuring the remote mirroring function, the network bandwidth should be considered in order to carry the network flow and the mirrored flow.

Keywords:

RSPAN: Remote Switched Port Analyzer.

RSPAN VLAN: Dedicated VLAN for RSPAN.

RSPAN Tag: The VLAN tag which is attached to MTP of the RSPAN datagrams.

Reflector Port: The local mirroring port between the RSPAN source and destination ports, which is not directly connected to the intermediate switches.

2.2. RSPAN Configuration Task List

1. Configure RSPAN VLAN
2. Configure mirror source port (cpu)
3. Configure mirror destination port
4. Configure reflector port
5. Configure remote VLAN of mirror group

1. Configure RSPAN VLAN

Command	Explanation
VLAN Configuration Mode	
<pre>remote-span no remote-span</pre>	To configure the specified VLAN as RSPAN VLAN. The no command will remove the configuration of RSPAN VLAN.

2. Configure mirror source port(CPU)

Command	Explanation
Global Mode	
<pre>monitor session <session> source {interface <interface- list> cpu [slot <slotnum>]} {rx tx both} no monitor session <session> source {interface <interface- list> cpu [slot <slotnum>]}</pre>	To configure mirror source port; The no command deletes the mirror source port.

3. Configure mirror destination port

Command	Explanation
Global Mode	
<pre>monitor session <session> destination interface <interface-number> no monitor session <session> destination interface <interface-number></pre>	To configure mirror destination interface; The no command deletes the mirror destination port.



4. Configure reflector port

Command	Explanation
Global Mode	
<pre>monitor session <session> reflector-port <interface-number> no monitor session <session> reflector-port</pre>	To configure the interface to reflector port; The no command deletes the reflector port.

5. Configure remote VLAN of mirror group

Command	Explanation
Global Mode	
<pre>monitor session <session> remote vlan <vid> no monitor session <session> remote vlan</pre>	To configure remote VLAN of mirror group, the no command deletes the remote VLAN of mirror group.

2.3. Typical Examples of RSPAN

Before RSPAN is invented, network administrators had to connect their PCs directly to the switches, in order to check the statistics of the network.

However, with the help of RSPAN, the network administrators can configure and supervise the switches remotely, which brings more efficiency. The figure below shows a sample application of RSPAN.

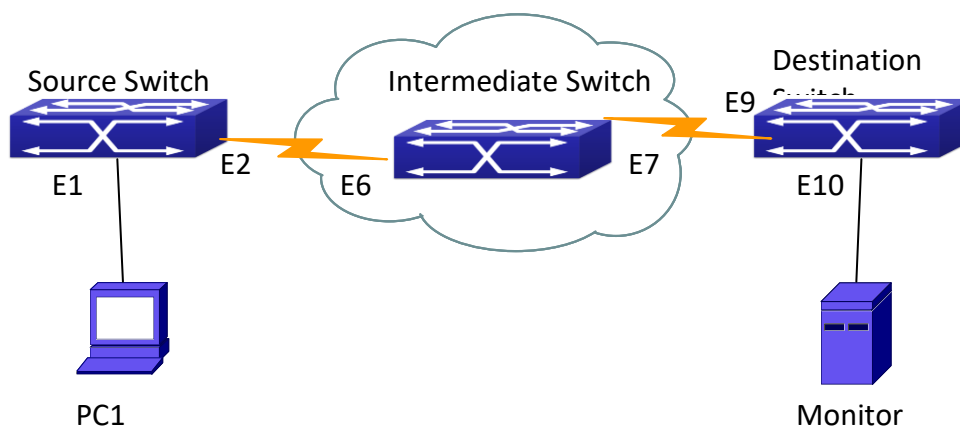

Fig 2-1 RSPAN Application Sample

Two configuration solutions can be chosen for RSPAN: the first is without reflector port, and the other is with reflector port. For the first one, only one fixed port can be connected to the intermediate switch. However, no reflector port has to be configured. This maximizes the usage of witch ports. For the latter one, the port connected to the intermediate switch is not fixed. Datagrams can be broadcasted in the RSPAN VLAN through the loopback, which is much more flexible.

The normal mode configuration is show as below:

❖ Solution 1:

Source switch:

Interface ethernet 1/0/1 is the source port for mirroring.

Interface ethernet 1/0/2 is the destination port which is connected to the intermediate switch.

RSPAN VLAN is 5.

```
Switch(config)#vlan 5
Switch(Config-Vlan5)#remote-span
Switch(Config-Vlan5)#exit
Switch(config)#interface ethernet 1/0/2
Switch(Config-If-Ethernet1/0/2)#switchport mode trunk
Switch(Config-If-Ethernet1/0/2)#exit
Switch(config)#monitor session 1 source interface ethernet1/0/1 rx
Switch(config)#monitor session 1 destination interface ethernet1/0/2
Switch(config)#monitor session 1 remote vlan 5
```

Intermediate switch:

Interface ethernet1/0/6 is the source port which is connected to the source switch.

Interface ethernet1/0/7 is the destination port which is connected to the intermediate switch.

The native VLAN of this port cannot be configured as RSPAN VLAN, or the mirrored data may not be carried by the destination switch.

RSPAN VLAN is 5.

```
Switch(config)#vlan 5
Switch(Config-Vlan5)#remote-span
Switch(Config-Vlan5)#exit
Switch(config)#interface ethernet 1/0/6-7
Switch(Config-If-Port-Range)#switchport mode trunk
Switch(Config-If-Port-Range)#exit
```

Destination switch:

Interface ethernet1/0/9 is the source port, which is connected to the source switch.

Interface ethernet1/0/10 is the destination port which is connected to the monitor. This port is required to be configured as an access port, and belong to the RSPAN VLAN.

RSPAN VLAN is 5.

```
Switch(config)#vlan 5
Switch(Config-Vlan5)#remote-span
Switch(Config-Vlan5)#exit
Switch(config)#interface ethernet 1/0/9
Switch(Config-If-Ethernet1/0/9)#switchport mode trunk
Switch(Config-If-Ethernet1/0/9)#exit
Switch(config)#interface ethernet 1/0/10
Switch(Config-If-Ethernet1/0/10)#switchport access vlan 5
Switch(Config-If-Ethernet1/0/10)#exit
```

❖ Solution 2:**Source switch:**

Interface ethernet 1/0/1 is the source port.

Interface ethernet 1/0/2 is the TRUNK port, which is connected to the intermediate switch. The native VLAN should not be a RSPAN VLAN.

Interface Ethernet 1/0/3 is a reflector port. The reflector port belongs the RSPAN VLAN, it is access port or TRUNK port of the RSPAN VLAN.

RSPAN VLAN is 5.

```
Switch(config)#vlan 5
Switch(Config-Vlan5)#remote-span
Switch(Config-Vlan5)#exit
Switch(config)#interface ethernet1/0/2
Switch(Config-If-Ethernet1/0/2)#switchport mode trunk
Switch(Config-If-Ethernet1/0/2)#exit
Switch(config)#interface ethernet 1/0/3
Switch(Config-If-Ethernet1/0/3)#switchport mode trunk
Switch(Config-If-Ethernet1/0/3)#exit
Switch(config)#monitor session 1 source interface ethernet1/0/1 rx
Switch(config)#monitor session 1 reflector-port ethernet1/0/3
Switch(config)#monitor session 1 remote vlan 5
```

Intermediate switch:

Interface ethernet1/0/6 is the source port which is connected to the source switch.

Interface ethernet1/0/7 is the destination port which is connected to the destination switch. The native VLAN of the port should not be configured as RSPAN VLAN, or the mirrored data may not be carried by the destination switch.

RSPAN VLAN is 5.

```
Switch(config)#vlan 5
Switch(Config-Vlan5)#remote-span
Switch(Config-Vlan5)#exit
Switch(config)#interface ethernet 1/0/6-7
Switch(Config-If-Port-Range)#switchport mode trunk
Switch(Config-If-Port-Range)#exit
```

Destination switch:

Interface ethernet1/0/9 is the source port which is connected to the source switch.

Interface ethernet1/0/10 is the destination port which is connected to the monitor. This port is required to be configured as an access port, and belong to the RSPAN VLAN.

RSPAN VLAN is 5.

```
Switch(config)#vlan 5
Switch(Config-Vlan5)#remote-span
Switch(Config-Vlan5)#exit
Switch(config)#interface ethernet 1/0/9
Switch(Config-If-Ethernet1/0/9)#switchport mode trunk
Switch(Config-If-Ethernet1/0/9)#exit
Switch(config)#interface ethernet 1/0/10
Switch(Config-If-Ethernet1/0/10)#switchport access vlan 5
Switch(Config-If-Ethernet1/0/10)#exit
```

2.4. RSPAN Troubleshooting

Due to the following reasons, RSPAN may not function:

- Whether the destination mirror port is a member of the Port-channel group. If so, please change the Port-channel group configuration;
- The throughput the destination port is less than the total throughput of the source mirror ports. If so, the destination cannot catch all the datagrams from every source ports. To

solve the problem, please reduce the number of the source ports, or mirror only single direction data flow, or choose some other port with higher capacity as the destination port.

- Between the source switch and the intermediate switch, whether the native VLAN of the TRUNK ports is configured as RSPAN VLAN. If so, please change the native VLAN for the TRUNK ports.
- After configured RSPAN, the vlan tag will be added on the packet of the egress mirror. It will cause the abort error frame on the reflection port, so the default MTU value of the switch should be modified.

3. ERSPAN

3.1. Introduction to ERSPAN

ERSPAN (Encapsulated Remote Switched Port Analyzer) eliminates the limitation that the source port and the destination port must be located on the same switch. This feature makes it possible for the source port and the destination port to be located on different devices in the network, and facilitates the network administrator to manage remote switches. Compared with the traditional RSPAN, ERSPAN configuration is simpler and it makes the monitored traffic to be transmitted in the specified tunnel.

To be noticed

1. Monitor source of ERSPAN monitor only supports port monitor, it does not support CPU monitor and flow monitor presently.
2. For the source and destination switches in the ERSPAN connections, a tunnel must be existed.
3. When configuring the remote mirror function, the network bandwidth should be considered in order to carry the network flow and the mirrored flow.

Keywords:

ERSPAN: Encapsulated Remote Switched Port Analyzer.

3.2. ERSPAN Configuration Task List

1. Specify mirror source port

Command	Explanation
Global Mode	
<pre>monitor session <session> source {interface <interface- list>} {rx tx both} no monitor session <session> source {interface <interface- list>}</pre>	Specify the mirror source port; the no command deletes the mirror source port.

2. Specify mirror destination tunnel

Command	Explanation
Global Mode	
<pre>monitor session <session> destination tunnel <tunnel- number> no monitor session <session> destination tunnel <tunnel- number></pre>	Specify the mirror destination tunnel; the no command deletes the mirror destination tunnel.

3.3. Typical Examples of ERSPAN

Before ERSPAN is invented, network administrators had to connect their PCs directly to the switches, in order to check the status of the network.

However, with the help of ERSPAN, network administrators can configure and supervise the switches remotely, which brings more efficiency.

In Layer 3 network, Device A connects to the marketing department through Ethernet 1/0/1, and connects to Ethernet1/0/2 of Device B through Ethernet 1/0/2; Device C connects to the server through Ethernet 1/0/2, and connects to Ethernet 1/0/1 of Device B through Ethernet 1/0/1. Server is able to monitor the bidirectional traffic of the marketing department across a GRE tunnel by configuring remote port mirroring. The figure below shows a sample application of ERSPAN.

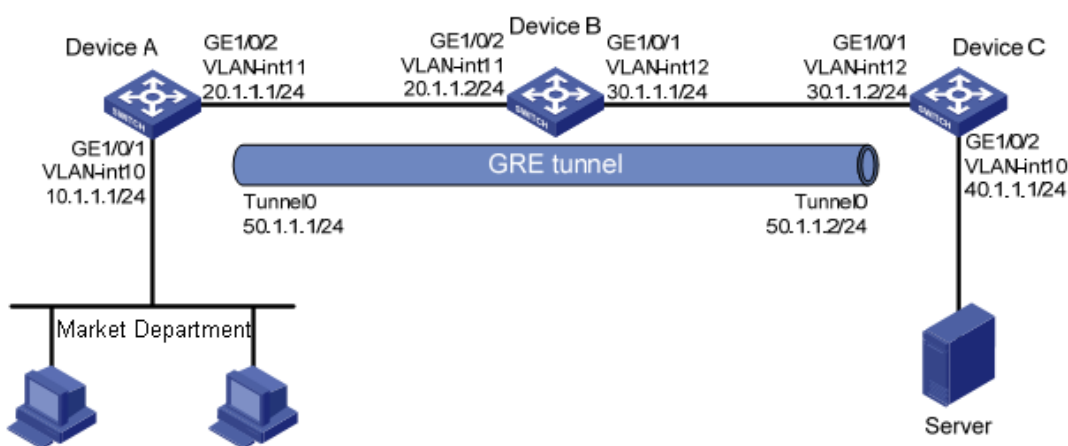

Fig 5-1 ERSPAN application diagram

Before configuring layer-3 remote port mirroring, make sure that you have created a GRE tunnel that connects the source and destination device, and ensure the normal transmitting for GRE tunnel.

The configuration of layer-3 remote port mirror needs to be processed on the source and destination devices respectively. Both the source and destination ports are configured on the source and destination devices, the difference in the following:

1) On Device A, configure the port which you want to monitor as the source port and configure the tunnel interface as the destination port.

2) On Device C, configure the physical port corresponding to the tunnel interface as the source port and configure the port that connects the data monitor device as the destination port.

❖ **Configure IP addresses**

Configure IP address and subnet mask for the interfaces, configuration procedures is omitted.

❖ **Configure Device A (the source device)**

Create interface Tunnel1, and configure an IP address and mask for it.

```
SwitchA(config)#interface tunnel 1
SwitchA(config-if-tunnel1)# tunnel mode gre ip
SwitchA (config-if-tunnel1)#ip address 50.1.1.1 255.255.255.0
```

Configure Tunnel1 to operate in GRE tunnel mode, and configure source and destination IP addresses for it.

```
SwitchA(config-if-tunnel1)# tunnel source 10.1.1.1
SwitchA(config-if-tunnel1)# tunnel destination 40.1.1.1
SwitchA(config-if-tunnel1)# exit
```

Configure OSPF protocol.

```
SwitchA (config)#router ospf
SwitchA (config-router)#network 0.0.0.0/0 area 0
SwitchA (config-router)#exit
```

Configure Ethernet 1/0/1 as a source port and Tunnel1 as the destination port of local mirroring group 1.

```
SwitchA(config)#monitor session 4 destination tunnel 1
SwitchA(config)#monitor session 4 source interface ethernet 1/0/1 both
```

❖ **Configure Device B (the intermediate device)**

Configure OSPF protocol.

```
SwitchB (config)#router ospf
SwitchB (config-router)#network 0.0.0.0/0 area 0
SwitchB (config-router)#exit
```

❖ **Configure Device C (the destination device)**

Create interface Tunne1, and configure an IP address and mask for it.

```
SwitchC(config)#interface tunnel 1
```



```
SwitchC (config-if-tunnel1)# tunnel mode gre ip
SwitchC (config-if-tunnel1)# ip address 50.1.1.2 255.255.255.0
```

Configure Tunnel1 to operate in GRE tunnel mode, and configure source and destination IP addresses for it.

```
SwitchC (config-if-tunnel1)# tunnel source 40.1.1.1
SwitchC (config-if-tunnel1)# tunnel destination 10.1.1.1
SwitchC (config-if-tunnel1)# exit
```

Configure OSPF protocol.

```
SwitchC (config)#router ospf
SwitchC (config-router)#network 0.0.0.0/0 area 0
SwitchC (config-router)#exit
```

Configure Ethernet 1/0/1 as a source port and Ethernet 1/0/2 as the destination port of local mirroring group 1.

```
SwitchC (config)#monitor session 1 destination interface ethernet 1/0/2
SwitchC (config)#monitor session 1 source interface ethernet 1/0/1 rx
```

3.4. ERSPAN Troubleshooting

If problems occur when configuring ERSPAN, please check whether the problem is caused by the following reasons:

- Make sure GRE tunnel configuration to ensure the normal transmission for the traffic.
- If the throughput of mirror destination port is smaller than the total throughput of mirror source port(s), the destination port will not be able to duplicate the traffic of all source port; please decrease the number of source ports, duplicate traffic for one direction only or choose a port with greater throughput as the destination port.