

## **QSR-2830 Series Routers**

### **Hardware Installation and Reference Guide 1.0**

## Copyright Statement

Qtech LLC ©2007

Qtech reserves all copyrights of this document. Any reproduction, excerpt, backup, modification, transmission, translation or commercial use of this document or any portion of this document, in any form or by any means, without the prior written consent of Qtech is prohibited.

## Exemption Statement

This document is provided "as is". The contents of this document are subject to change without any notice. Please obtain the latest information through the Qtech Networks website. Qtech Networks endeavors to ensure content accuracy and will not shoulder any responsibility for losses and damages caused due to content omissions, inaccuracies or errors.

## Preface

Thank you for using our products. This manual will guide you through the installation of the device.

This manual describes the functional and physical features and provides the device installation steps, hardware troubleshooting, module technical specifications, and specifications and usage guidelines for cables and connectors.

## Audience

It is intended for the users who have some experience in installing and maintaining network hardware. At the same time, it is assumed that the users are already familiar with the related terms and concepts.

## Obtaining Technical Assistance

- Qtech Networks Website: [Qtech website](#)
- Technical Support Website: [Qtech](#)

## Related Documents

Documents	Description
Configuration Guide	Describes network protocols and related mechanisms that supported by the product, with configuration examples.

## Symbol Conventions



### Note

Means reader take note. Notes contain helpful suggestions or references.



### Caution

Means **reader be careful**. In this situation, you might do something that could result in equipment damage or loss of data.



## Product Overview

The QSR-2830 series routers are data communication products independently developed by Qtech Networks Co. Ltd. by using advanced semiconductor technologies and communication control technologies. Qtech series routers are developed in full compliance with international standards, therefore, it is similar to major routers in terms of use and configuration approach. Network administrators who are familiar with the configuration commands of major routers may use the routers without receiving training first.

### About the QSR-2830-HI

Developed from Qtech's RSR (Reliable multi-Services Router), QSR-2830, as the next generation access router, is characterized by its applicability in a variety of access scenarios, such as routing, switching, security, 3G/4G and WiFi. With improvements in performance, port number, rate and reliability, QSR-2830 offers integrated solutions for enterprise edge networks at minimum costs. The Router provides a consolidated service infrastructure that enables scalable deployment of new applications to better address the diversified demands for future business development. QSR-2830 is an ideal choice for branch offices of medium and large-sized financial institutions, governments or enterprises to access multiple services in a cost-efficient way.

Adopting advanced operation system, QSR-2830 supports Qtech's patented technologies REF (Qtech Express Forwarding), VCPU (virtual CPU) and X-Flow. All these leading technologies guarantee stable forwarding even when multiple services are enabled on the Router. Because of Stateful Firewall, QSR-2830 is good at resisting flow attacks. The Router delivers plentiful backup solutions, QoS/HQoS characteristics, service-rich features, including MPLS, VPN, multicast, IPv6, VoIP, NAT and MVRF. In this manner, users do not need to purchase additional software Licenses or service modules.

Supporting HSIC service modules, QSR-2830 totally delivers up to 10Gbps bandwidth. The Router also supports expansion of 10G Ethernet interface modules and other WAN and LAN modules of diverse types, multiple functions and high intensity. Such expandability serves as a foundation for more combination possibilities. Plugging and unplugging of hot-swappable HSIC service modules have no influence on forwarding services of other operating modules. Plus, QSR-2830 supports alternating/direct current power supply redundancy, which helps enhance reliability.

Aimed at offering users simplistic and efficient network, QSR-2830 supports simplistic network solutions, including device virtualization, WAN port aggregation, IDA and ITO.

Different SIC slots support different extension service modules to flexibly meet users' requirements.

Table 0-1 Extension Service Modules Supported by the QSR-2830 Router

Slot	Supported Service Modules
Slot 2	QSR-M-2830-2E1/CE1
Slot 3	QSR-M-2830-2E1/CE1

Slot 4	QSR-M-2830-PWR-AC, QSR-M-2830-2E1/CE1
Slot 5	QSR-M-2830-PWR-AC, QSR-M-2830-2E1/CE1



**Caution**

Up to four HSIC modules are supported per router. Modules with OFL buttons are hot-swappable, while modules without OFL buttons are not hot-swappable. QSR-M-2830-2E1/CE1 and HSIC-2HS support hot swapping.



**Caution**

Up to two power supply modules are supported. Slot 4 and Slot 5 support power supply modules. Hot swapping is supported.



**Caution**

Up to two DHSIC modules are supported. Modules with OFL buttons are hot-swappable, while modules without OFL buttons are not hot-swappable.



**Caution**

Slot 4 and Slot 5 support DHSIC modules. Hot swapping is supported.

## Technical Specifications

Table 0-2 Technical Specifications of the QSR-2830 Series Router

<b>Model</b>	QSR-2830
<b>Interfaces</b>	One Console/AUX combo port One USB port One SD card slot One FUNC button 24 10/100/1000Mbps Ethernet ports Four GE copper ports (including two GE combo ports)
<b>HSIC Slots</b>	4 (Two slots only support HSIC modules; another two slots support HSIC modules, DHSIC modules and power supply modules. )
<b>Processor</b>	64-bit multinuclear processor
<b>BOOT ROM</b>	8MB
<b>NAND FLASH</b>	256MB
<b>DDR III</b>	1GB
<b>Dimensions (W x H x D)</b>	440mm x 44mm x 340mm
<b>Input Voltage</b>	100VAC to 240VAC, 50 Hz to 60 Hz
<b>Power Consumption</b>	< 48W
<b>Operating Temperature</b>	0°C to 45°C (32°F to 113°F)
<b>Storage Temperature</b>	-40°C to 70°C (-40°F to 158°F)
<b>Operating Humidity</b>	5% to 95% RH (non-condensing)
<b>Storage Humidity</b>	5% to 95% RH (non-condensing)

## Access density and processing capability

The QSR-2830 supports four HSIC slots, 24 GE Ethernet ports, and four GE copper ports (including two GE combo ports). The Router provides one FUNC multi-functional button to upgrade the operating system as well as one SD card slot and one USB port to save configuration to storage devices. These make the router an ideal choice for large/medium-sized branches.

## Reliability

The router adopts backup center technologies, which greatly improves network reliability. Various backup modes are available for high reliability requirements.

## Compatibility

The router is fully compatible with devices from other vendors.

## Power supply

By using high-quality standard power supplies, the router provides protection against surge, overvoltage, undervoltage, overcurrent to deliver stable and reliable output. In addition, it supports transient power interruption protection and power redundancy.

## Construction

With the rack mount 1U chassis with EMI shielding, the router can be installed in a bracket or a workbench. QSR-2830 is highly resistant to shock, high/low temperature, and electromagnetic radiation, and works stably.

## LED Indicators

Table 0-3 LED Indicators on the QSR-2830 Router

LED	Panel Identification	State	Meaning
System status LED	SYS	Off	The router is not receiving power, or the router is receiving power but the system fails.
		Solid green	The system is operational.
		Blinking green	The system starts up.
		Solid red	The system is faulty.
Active power status LED	PWR	Solid green	Power supply is operational.
		Solid yellow	No power supply is available.
Backup power status LED	PWR_BAK	Solid green	Two or more than two backup power are receiving power.
		Off	One or none backup power is receiving power.

USB device status	USB	Off	No USB device is inserted.
		Solid green	The USB device is initialized and is not exchanging data.
		Blinking green	The USB device is exchanging data.
		Solid red	The USB device is faulty.
SD card status	SD	Off	No SD card is inserted.
		Solid green	The SD card is initialized and is not exchanging data.
		Blinking green	The SD card is exchanging data.
		Solid red	The SD card is faulty.
SFP port status	SFP	Off	The port is NOT connected.
		Solid yellow	The port is connected at 100Mbps.
		Blinking yellow	The port is connected at 100Mbps and is exchanging data.
		Solid green	The port is connected at 1,000Mbps.
		Blinking green	The port is connected at 1,000Mbps and is exchanging data.
GE copper port status	1-24	Off	The port is NOT connected.
		Solid yellow	The port is connected at 10/100Mbps.
		Blinking yellow	The port is connected at 10/100Mbps and is exchanging data.
		Solid green	The port is connected at 1,000Mbps.
		Blinking green	The port is connected at 1,000Mbps and is exchanging data.

## Back Panel

Figure 0-1 Back Panel of QSR-2830 Router





Note:	15: SLOT 2	18: SLOT 5
	16: SLOT 3	19: Grounding point
	17: SLOT 4	20: Slot identifier



**Note** If you cannot determine the number of the slot where the current module resides, you can run the **show slots** command in privileged EXEC mode. The router version information includes the slot number of each module.



**Note** SLOT 4 and SLOT 5 support DHSIC/power modules.

## About Fixed Ports

This section describes fixed ports on the QSR-2830 series router.

### Console/Auxiliary Combo Port

#### Features

The QSR-2830 series router provides one Console/AUX combo port.

**TABLE 0-4 SPECIFICATIONS OF THE CONSOLE/AUX COMBO PORT**

Index	Parameter
Interface Standard	EIA/TIA-RS232
Connector	RJ-45
Rate	Supports 9,600bps, 57,600bps and 115,200bps baud rates. The default is 9,600bps.

#### Cables

Use DB9F-to-RJ45 cables.

### GE Ports

#### Port Image and LED Indicators

**FIGURE 0-2 APPEARANCE OF THE 24 GE PORTS**

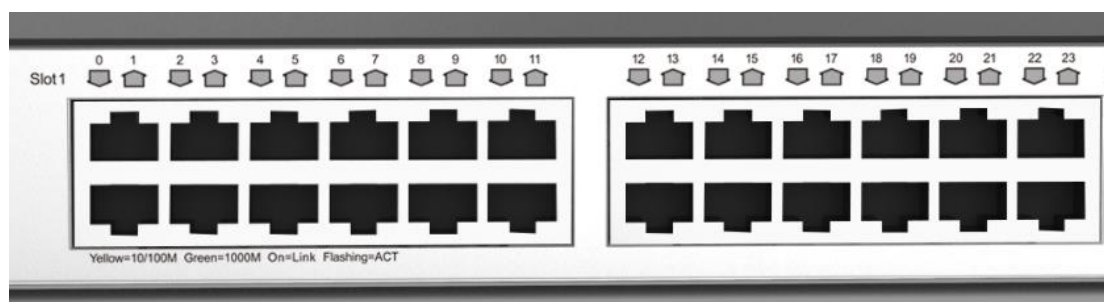

For descriptions of GE port Link/ACT LED indicators, see the “LED Indicators” section in Chapter 1.

### Features

An QSR-2830 series router provides 24 fixed 10/100/1000Mbps copper ports. And RJ45 connectors are used for connection.

The following table describes the basic features of the copper ports.

**TABLE 0-5 SPECIFICATIONS OF GE PORTS**

<b>Protocol</b>	IEEE Std 802.3-2012
<b>Quantity</b>	24
<b>Interface Type</b>	10Base-T/100Base-TX/1000Base-T interfaces

### Cables

1000BASE-T interfaces: 100-ohm Category 5e UTP/STP cables, maximum cabling distance 100m

100BASE-TX interfaces: 100-ohm Category 5/5e UTP/STP cables, maximum cabling distance 100m

10BASE-T interfaces: 100-ohm Category 3/4/5/5e UTP/STP cables, maximum cabling distance 100m

If the port supports Auto-MDI/MDI-X, both straight-through and crossover cables can be used. QSR-2830 supports MDI/MDI-X.

Considering that you may customize cables, the following section describes how to wire straight-through and crossover cables.

As shown in the following figure, the pins of the RJ-45 connector are numbered 1 to 8, counting from left to right when the connector is viewed from the side without the latching tab.

**FIGURE 0-3 RJ-45 CONNECTOR PIN NUMBER**

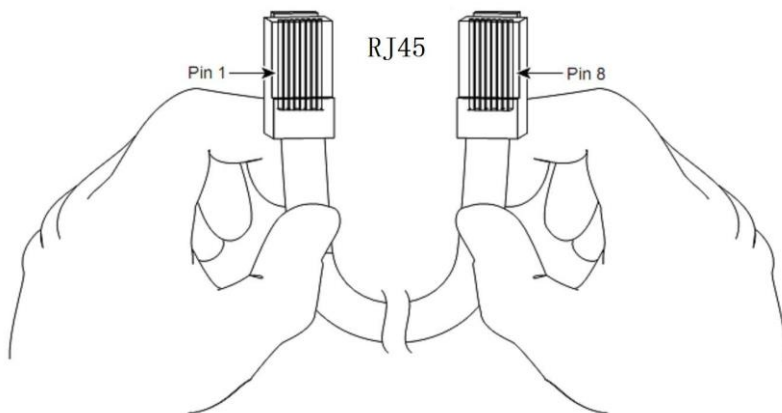

**TABLE 0-6 1000BASE-T PIN ASSIGNMENTS**

Pin	MDI Mode	MDI-X Mode
-----	----------	------------

1	Media Dependent Interface A+	Media Dependent Interface B+
2	Media Dependent Interface A-	Media Dependent Interface B-
3	Media Dependent Interface B+	Media Dependent Interface A+
4	Media Dependent Interface C+	Media Dependent Interface D+
5	Media Dependent Interface C-	Media Dependent Interface D-
6	Media Dependent Interface B-	Media Dependent Interface A-
7	Media Dependent Interface D+	Media Dependent Interface C+
8	Media Dependent Interface D-	Media Dependent Interface C-

When 1000BASE-T interfaces are in use, connect all four pairs of pins. The pin connection rule is shown in Table 0-7.

**TABLE 0-7 1000BASE-T CONNECTION**

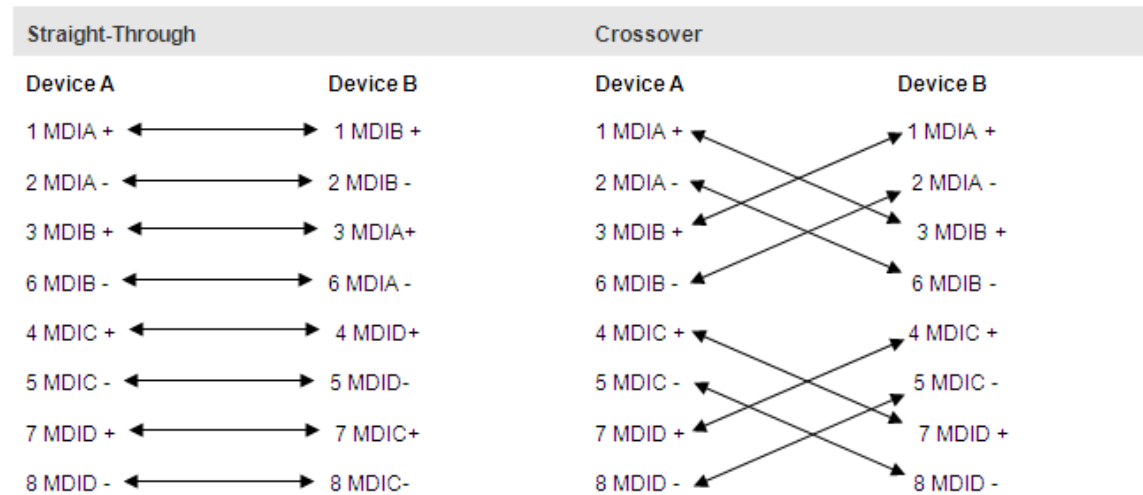

**TABLE 0-8 100BASE-TX/10BASE-T PIN ASSIGNMENTS**

Pin	MDI Mode	MDI-X Mode
1	Output Transmit Data+	Input Receive Data+
2	Output Transmit Data-	Input Receive Data-
3	Input Receive Data+	Output Transmit Data+
6	Input Receive Data-	Output Transmit Data-
4, 5, 7, 8	Not Used	Not Used

**TABLE 0-9 100BASE-TX/10BASE-T CONNECTION**

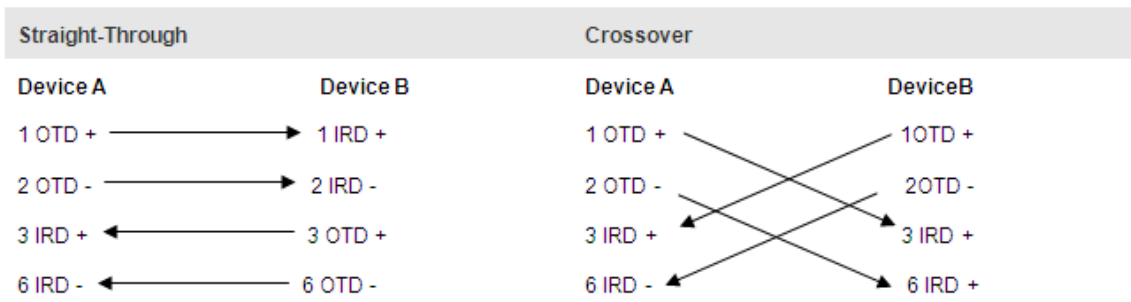

## USB Port

### Port Image and LED Indicators

The following figure shows the fixed USB ports.

**FIGURE 0-4 USB PORT**



For descriptions of USB port indicator, see the “LED Indicators” section.

### Features

The QSR-2830 series router provides one fixed USB port, through which the user can read configurations from the USB device, or save configurations to the USB device.

**TABLE 0-10 SPECIFICATIONS OF THE USB PORT**

Index	Parameters
Interface Standard	USB 2.0
Connector	USB Host
Rate	1.5Mbps, 12Mbps, 480Mbps
Interface Type	Host
Hot Swapping	Supported



**Caution**

The hot swapping for the USB device must strictly follow the “Configuring Reliability” chapter in the related software configuration guide. For the avoidance of system abnormality, hot swapping is not allowed unless the command for unplugging the USB is entered.



**Caution**

The USB device here refers to USB flash disks. Products by mainstream manufacturers are recommended, such as Kingston and Sandisk.



**Caution**

USB devices only support .FAT32 files. Non-.FAT32 files should be converted to the .FAT32 format before being recognized.

*Cables*

If you connect a USB device with a USB extension cable, the cable must be less than 5 meters.

**SD Card Slot**

*Port Image and LED Indicator*

**FIGURE 0-5 SD CARD SLOT**



For descriptions of SD card indicator, see the “LED Indicators” section.

*Features*

The QSR-2830 series router provides one fixed SD card slot, through which the user can read configurations from an SD card, or save configurations to the SD card. You can save the operating system to the SD card, and upgrade the operating system by pressing FUNC button on the panel.

**TABLE 0-11 SPECIFICATIONS OF THE SD CARD SLOT**

Index	Parameters
-------	------------

Index	Parameters
Interface Standard	SD/SDHC
Connector	SD connector
Rate	5Mbps/sec max
Interface Type	Device
SD Card	Qtech Networks SDHC card/ Kingston/ 4GB/ class_4
Hot Swapping	Supported



**Caution**

The hot swapping for the SD device must strictly follow the “Configuring Reliability” chapter in the related software configuration guide. For the avoidance of system abnormality, hot swapping is not allowed unless the command for unplugging the SD card is entered.



**Caution**

SD cards only support .FAT32 files. Non-.FAT32 files should be converted to the .FAT32 format before being recognized.

*Cables*

N/A

**FUNC Button**

*FUNC Button Image*

**FIGURE 0-6 FUNC BUTTON**

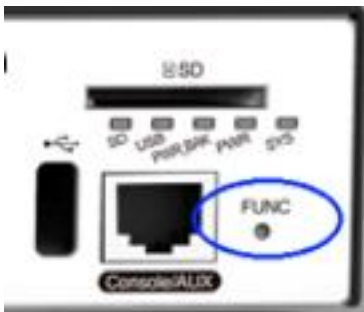

The FUNC button is close to the SD card slot on the front panel. It is used for one-click upgrade. To avoid careless touching, the button is designed to be pressed using a tiny needle.

## Features

When an SD card or a USB flash disk is inserted into the device, press the FUNC button. Then, the system searches for the installation packages and configuration files that are applicable to the current device in the root directories of the SD card and USB flash disk in sequence. After successfully finding the corresponding installation packages and configuration files, the system checks the validity of the files and then upgrades the device by using the installation packages and configuration files. After the upgrade, the system resets and restarts based on the new software versions and configuration files.

When NO SD card or a USB flash disk is inserted into the device, press the FUNC button to reset the system.



### Note

When a storage medium is inserted, the system scans for an SD card first. If no SD card is inserted or the inserted SD card does not contain applicable installation packages or configuration files, the system scans for a USB flash drive. If neither the inserted SD card nor the USB flash drive contains applicable installation packages or configuration files, the software versions and configuration files are not upgraded. Only the system resets, and restarts based on the original software versions and configuration files.



### Note

One-click upgrade of the software version must strictly follow the “Configuring Reliability” chapter in the related software configuration guide. After the system has scanned an SD card or USB flash drive, press the FUNC button shortly.

## QSR-M-2830-2E1/CE1 Interface Module

HSIC module model: QSR-M-2830-2E1/CE1

### Image and Indicators

The following figure shows the image of a 2-port E1/CE1 interface module.

FIGURE 0-7 HSIC-2E1-CE1

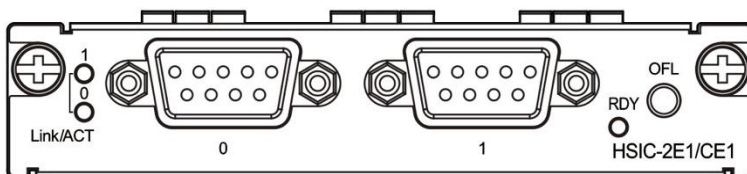

Each module has an interface status indicator (**Link/ACT** indicator) and the module **RDY** indicator. And an **OFL** hot swapping button is provided.

The following table describes LED indicators.

**TABLE 0-12 LED INDICATORS ON THE SIC-1E1-F MODULE**

LED	Panel Identification	State	Meaning
Module status LED	RDY	Off	The module is not receiving power; the module is not properly inserted; or the module is removable.
		Blinking green	Initialization in progress
		Solid green	Initialization is complete and the module is operational.
Port 0-1 status LED	Link/ACT	Off	The port is not connected.
		Blinking green	The port is connected properly and is transceiving data.
		Solid green	The port is properly connected.
Hot Swapping Button	OFL	-	Press the button for more than 3s. When the RDY indicator starts to blink, release the button, and the automatic unmounting of the module is complete. After the RDY indicator turns off, remove the module.

*Features*

The following table describes the basic features.

**TABLE 0-13 SPECIFICATIONS OF THE QSR-M-2830-2E1/CE1 MODULE**

<b>Number of Ports</b>	Two
<b>Interface Type</b>	DB9 female connector
<b>Cables</b>	Balanced cables or non-balanced cables
<b>Standard Compliance</b>	ITU-T G.703
<b>Operating Temperature</b>	Operating temperature: 0°C to 45°C (32°F to 113°F) Storage temperature: -40°C to 70°C (-40°F to 158°F)
<b>Humidity</b>	Operating humidity: 5% to 95% RH
<b>EMC</b>	EMI: GB 9254-2008 Class A
	EMS: GB/T 17618-1998

*Cables*

The following cables are provided:

- Balanced cable with the crystal connector



- Balanced cable with the crystal jack
- Non-balanced cable

### Balanced cable with the RJ-45 Plug

One end is the DB9 male connector, and the other end is the RJ-45 plug. The characteristic impedance of the cable is 120Ω.

FIGURE 0-8 BALANCED CABLE WITH THE RJ-45 PLUG

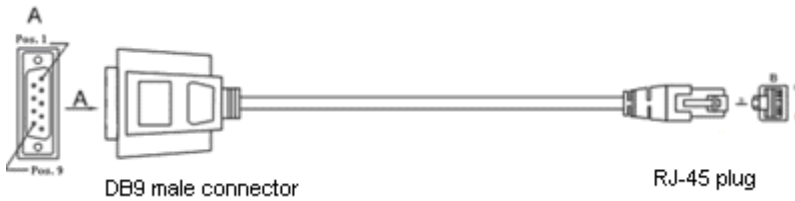

Considering that you may customize cables, the following section describes connection modes and the signal.

TABLE 0-14 SIGNALS OF THE DB9 MALE TO RJ-45 PLUG CABLE

DB9M	RJ-45 Plug	Signal
1	5	RX Ring
2	4	RX Tip
4	1	TX Tip
5	2	TX Ring

### Balanced cable with the RJ-45 jack

One end is the DB9 male connector, and the other end is the RJ-45 jack. The characteristic impedance of the cable is 120Ω.

FIGURE 0-9 BALANCED CABLE WITH THE RJ-45 JACK



Considering that you may customize cables, the following section describes connection modes and the signal.

TABLE 0-15 SIGNALS OF THE DB9 MALE TO RJ-45 JACK CABLE

DB9M	RJ-45 Jack	Signal
1	2	RX Ring

2	1	RX Tip
4	4	TX Tip
5	5	TX Ring

### Non-balanced cable

One end is the DB9 male connector, and the other end is attached with two male BNC connectors. The characteristic impedance of the cable is 75Ω

FIGURE 0-10 NON-BALANCED CABLE



The cables are customer supplied. For the use of cables, see Chapter 6.



**Caution** External antennas are not hot-pluggable. Therefore, installing or removing external antennas require power off of the router.

### Power Supply Module

#### QSR-M-2830-PWR-AC Power Supply Module

*Image*

FIGURE 0-11 QSR-M-2830-PWR-AC

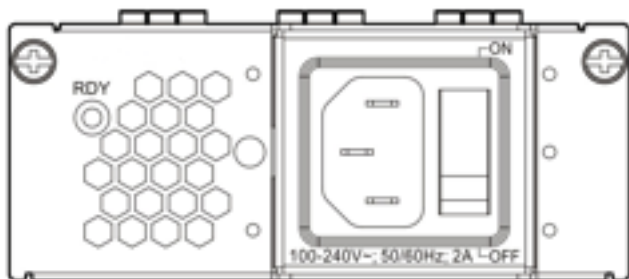

## Indicator

TABLE 0-16 LED INDICATORS ON THE QSR-M-2830-PWR-AC MODULE

LED	Panel Identification	State	Meaning
Module status LED	RDY	Off	The module is faulty.
		Solid green	The module is operational.

## Features

TABLE 0-17 SPECIFICATIONS OF THE QSR-M-2830-PWR-AC MODULE

<b>Model</b>	QSR-M-2830-PWR-AC
<b>Rated AC Voltage Range</b>	100VAC to 240VAC, 50-60Hz
<b>Max AC Voltage Range</b>	90VAC to 264VAC, 50-60Hz
<b>Max Output Power</b>	60W
<b>Hot Swapping</b>	Supported
<b>Redundancy</b>	Support Active-Backup power redundancy
<b>Over-Voltage Protection</b>	Supported
<b>Over-Current Protection</b>	Supported
<b>Power Cord</b>	10A power cord
<b>Dimensions (W x D x H)</b>	98.2mm x 41mm x 176mm (connector excluded)
<b>Operating Temperature</b>	0°C to 45°C (32°F to 113°F)
<b>Storage Temperature</b>	-40°C to 70°C (-40°F to 158°F)
<b>Operating Humidity</b>	5% to 95% RH (non-condensing)
<b>Storage Humidity</b>	5% to 95% RH (non-condensing)

## Features of QSR-2830 Series Routers



**Note** For software functions, see the supporting software description.

## Supporting Multiple Protocols

- Applicable to various network environments.

- Providing RJ-45 interfaces for twisted pairs and SFP ports, supporting Ethernet, ARP, and 802.1Q protocols.
- Supporting various WAN protocols, including X.25, frame relay, HDLC, PPP, and SLIP.
- Supporting the TCP/IP protocol stack and the protocols such as IP, Internet Control Message Protocol (ICMP), Internet Group Management Protocol (IGMP), TCP and UDP on the network layer.
- Supporting multiple dynamic routing protocols over IP, including RIP (V1/V2), RIPng, Open Shortest Path First (OSPF) (V1/V2/V3), and policy-based routing.
- Supporting the Simple Network Management Protocol (SNMP).
- Supporting Telnet and reverse Telnet.
- Supporting Dynamic Host Configuration Protocol (DHCP) Server, DHCP Client, DHCP Relay, and Trivial File Transfer Protocol (TFTP).
- Supporting backup, Virtual Router Redundancy Protocol (VRPP) with high reliability.
- Supporting Point-to-Point Protocol over Ethernet (PPPOE).
- Supporting DNS static domain name resolution and Dynamic Domain Name Server (DDNS). DNS indicates Domain Name System.
- Supporting upgrade over the asynchronous file transfer protocols of X-MODEM.
- Supporting NAT/NAT-PT, ACL and AAA.
- Supporting Internet Protocol Security (IPSEC), Layer 2 Tunneling Protocol (L2TP), and Point to Point Tunneling Protocol (PPTP).
- Supporting complete MPLS VPN.

## User-Friendly Interfaces

- Providing standard operating interfaces and intuitive configuration procedures with each command described in details in on-line help.
- Providing descriptions and examples of each command as well as comprehensive fault analysis.

## Powerful Backup Function

- Supporting route backup through routing protocols.
- Supporting the interface backup function

## Multiple Diagnosis and Management Tools

- Providing complete debugging and tracing tools as well as complete DEBUG commands for easier accurate location of various network faults.
  - Providing rich statistics and information display functions to allow the users to easily know the network performance and running status.
  - Supporting SNMP for monitoring and controlling the router by using common network management software.
  - Supporting login through terminals.
- 1) Supporting configuration over the Console port
  - 2) Supporting login and configuration over Telnet.
  - 3) Supporting login and configuration over the serial port.
  - 4) Supporting login and configuration over remote dial-up.

## Superior Security

- Using perfect firewall and IP packet filtering technology to enforce strict check on network addresses, port numbers, or protocol types.
- Supporting AAA and RADIUS.
- Realizing Password Authentication Protocol (PAP) and Challenge Handshake Authentication Protocol (CHAP) on Point-to-Point Protocol (PPP), supporting callback, and enhancing security.
- Providing level-based password check and security logs.
- Implementing dynamic routing-protocol password/key authentication in OSPF and RIP V2.
- Supporting NAT.
- Providing IPSEC/IKE data encryption
- Supporting GRE tunnel encapsulation
- Providing VLAN technology

## Multiple Terminal Functions

- Enabling both the synchronous and asynchronous ports to connect the terminals.
- Supporting the auto command function (automatically run commands) and the user-based auto command function (allow different users to run different commands) on terminal ports.

- Supporting the command alias and telnet script, which can be used together with the auto command function to directly log in to the server after pressing **Enter** on the terminal.
- Supporting the fixed terminal dial-up function based on different operating systems, where a terminal uses the same terminal number for multiple times of login.
- Supporting the real terminal. The terminal logs in to the server over the router and act as a real terminal (tty) for the server, not needing the modification of the old programs, thereby protecting the existing investment.
- Implementing the router-based multi-screen terminal function, which allows the terminal to easily switch over between different servers or different screens of one server.
- Supporting the reverse Telnet function, which enables easy management of various serial port devices over a router.

## Easy Upgrade

- Supporting the asynchronous file transfer X-MODEM protocol, which allows the download of new versions over the Console port or synchronous port in various operation environments (Windows XP, Windows NT, UNIX, and DOS).
- Supporting the download of the new software versions over TFTP.
- Supporting BOOTROM online upgrade.
- Supporting the USB device and SD card for one-click upgrade.
- Supporting dual BOOTROM.

## Preparing for Installation

### Precautions

Routers are critical repeaters in network connection, and affect the operation of the whole network.

The following are recommended during the installation and use of a router:

- Keep the router dry.
- Place the router away from heating sources.
- Ensure the normal grounding.
- Wear electrostatic discharge (ESD) straps during installation and maintenance.
- Do not wear any loose clothes that may hook the components. Therefore, fasten your belts, scarves, and tuck the sleeves.
- Keep the tools and components away from walking areas.
- Use Uninterruptible Power Supply (UPS) to avoid power failure as well as power interference.
- Replace the battery with an equal one made by the same factory.



**Caution** Risk of Explosion if battery is replaced by an incorrect type.  
Dispose or used batteries according to the instructions.

---

### Installation Environment Requirements

Qtech routers are intended for indoor use. For their normal operation and maximum service life, they must be installed at locations that meet the following requirements:

- Temperature and humidity requirements
- Cleanness requirements
- Anti-static requirements
- Anti-interference requirements
- Anti-lightning requirements
- Installation platform check

## Temperature and Humidity Requirements

To ensure the normal operation and maximize the service life of a router, you should keep proper temperature and humidity in the equipment room. If the relative humidity is high for a long time, the insulating materials may have poor insulation, electric leakage or other mechanical performance degrade may occur. And if the relative humidity is too low, the insulating washers may become dry and shrink, which may cause loosened screws. In addition, static electricity may easily occur in dry weathers, harming the internal circuitry of the router. High temperature will speed the aging of insulation materials, lowering the router's reliability and shorten its service life.

The following are Qtech QSR-2830 series routers' Requirements for the temperate and humidity requirements:

Temperature: 0°C to 45°C (32°F to 113 °F)

Relative humidity: 5%–95% RH



### Note

The ambient temperature and humidity refer to the values measured at the place 1.5m above the floor and 0.4m in the front of the router rack without protective boards.



### Note

The temperature and humidity requirements may be different for different products. For details, see descriptions about the characteristic parameters for each product.

## Cleanness Requirements

Dust poses a serious threat to device operation. Dust that falls onto the surface of the device can be absorbed onto metal contact points by static electricity, resulting in poor contact. Electrostatic absorption of dust occurs more easily when the relative humidity is low, which may shorten the useful life of the device and cause communication failures.

The following table describes Qtech routers' requirements for the dust content and granularity in the equipment room:

Maximum diameter (μm)	0.5	1	3	5
Maximum concentration (Particles/m <sup>3</sup> )	$1.4 \times 10^7$	$7 \times 10^5$	$2.4 \times 10^5$	$1.3 \times 10^5$

Besides, the content of salts, acids and sulfides in the air are also strictly limited for the equipment room. These substances can accelerate metal corrosion and aging of some parts. The following table describes the limit of some hazardous gases such as SO<sub>2</sub>, H<sub>2</sub>S, NO<sub>2</sub> and Cl<sub>2</sub> in the equipment room.

Gas	Average (mg/m <sup>3</sup> )	Maximum (mg/m <sup>3</sup> )
SO <sub>2</sub>	0.2	1.5



H <sub>2</sub> S	0	0.03
NO <sub>2</sub>	0.04	0.15
NH <sub>3</sub>	0.05	0.15
Cl <sub>2</sub>	0.01	0.3

## Anti-static Requirements

The router circuitry is designed with anti-static protection, but excessive static electricity may still damage router circuit boards. The static electricity of the network connected with the routers comes largely from the following sources:

- Outdoor electric field produced by the high-voltage supply cable and lightning.
- Indoor systems such as the indoor floor and the entire structure.

Therefore, the following requirements must be met:

- Ensure proper grounding of the device and floor.
- Prevent indoor dust.
- Maintain proper temperature and humidity.
- Wear ESD wrist straps and ESD lab coats when touching a circuit board.
- Put the removed circuit board face up on an anti-static workbench or in an electromagnetic shielding bag.
- Touch the external edge of the board and avoid touching the parts on the board directly with hands when observing or carrying the detached circuit board.

## System Grounding Requirements

A good grounding system is the basis for the stable and reliable operation of the QSR-2830 and the key to prevent lightning stroke and resist interference. Please carefully check the grounding conditions on the installation site according to the grounding requirements, and perform grounding properly as needed.

## Safety Grounding

The equipment using AC power supply must be grounded by using the yellow/green safety grounding cable. Otherwise, when the insulating resistance decreases the power supply and the enclosure in the equipment, electric shock may occur.



### Caution

The building installation shall provide a means for connection to protective earth, and the equipment is to be connected to that means.

---

## EMC Grounding

The ground required for EMC design includes shielding ground, filter ground, noise and interference suppression, and level reference. All the above constitute the comprehensive grounding requirements. The grounding resistance should be less than  $1\Omega$ .

## Anti-interference Requirements

Anti-interference indicates the electromagnetic and current interference. The following are the anti-interference requirements:

- Take effective measures for the power system to prevent the interference from the electric grid.
- Separate the working ground of the network output engine from the grounding device of the power equipment or the anti-lightning grounding device.
- Keep away from the high-frequency large-current devices like high-power radio transmitters and radar transmitters.
- Take electromagnetic shielding measures when necessary.
- The QSR-2830 router is a CLASS A product. In daily scenarios, it may cause radio interference. In this case, users need to adopt practical measures to reduce the radio interface generated by the QSR-2830.

## Anti-Lightning Requirements

Qtech series routers are provided with anti-lightning protection. However, as an electric device, it is still vulnerable to powerful lightning. Therefore, the following measures must be taken to prevent lightning:

- Ensure good contact between the grounding cable of the router and the ground.
- Ensure that the neutral point of the AC power socket is in good contact with the ground.
- Add a lightning arrester in front of the input of the power supply to enhance the anti-lightning effect of the power supply.
- For improve the anti-lightning effect, users can attach special lightning prevention equipment to the input end of outdoor signal lines such as E1 line and T1 line that connected with the interface modules of QSR-2830 series.

## Checking the Installation

The following requirements must be met whether routers are installed in a cabinet or placed on a workbench:

- Sufficient spacing is reserved at the air inlets and outlets of the routers for good heat dissipation of the routers.
- The cooling systems of the cabinet and the workbench are proper.
- The cabinet or workbench is firm enough to support the router and its accessories.

- The cabinet and workbench are properly mounted.

## Installation Tools

The following must be ready for smooth installation:

- Installation tools
- Connection cables
- Related devices

Installation tools include:

- Phillips screwdrivers
- ESD wrist strap

Connection cables include:

- Power cable
- Configuration cable
- Ethernet cable
- Module interface cable



### Note

The power cables and the configuration cables are provided along with Qtech QSR-2830 series router delivery, but the Ethernet cables and module interface cables are customer supplied.

---

Related devices include:

- HUB or switch
- CSU/DSU or other DCE device
- Configuration terminal that can be a terminal or a PC installed with HyperTerminal
- Router modules
- Power socket

## Installing the Router

### Installation Flowchart

The following is the flowchart of installing a Qtech series router. Follow the process to ensure a smooth installation and

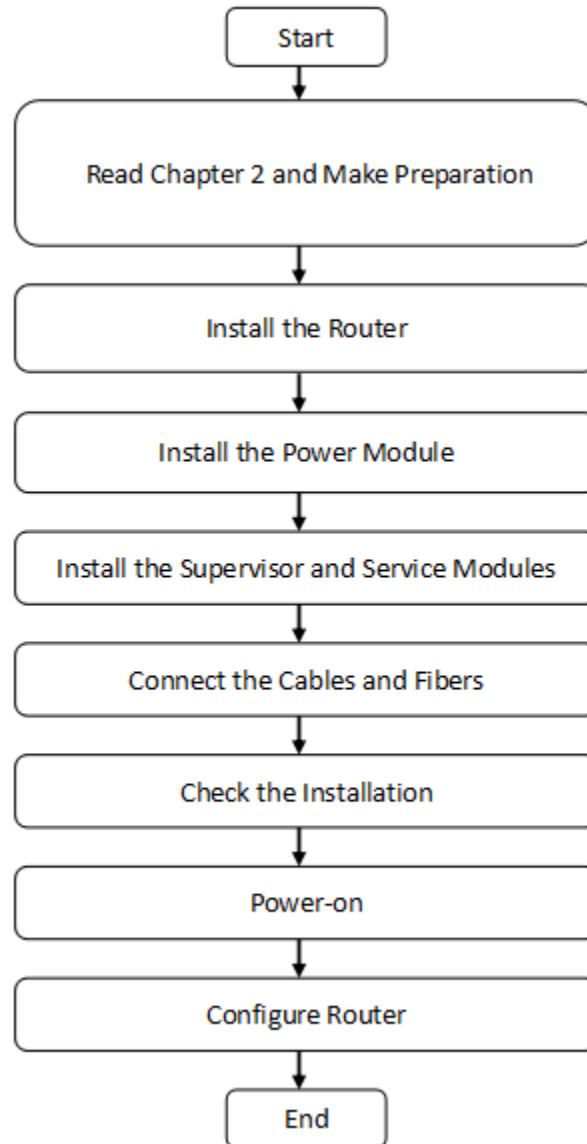

avoid any damage to the router.

### Fastening the Router

Fastening a router refers to the process of mounting a router to the specified location, which occurs after the installation preparation is complete. Routers are usually mounted:

- In the cabinet
- On the workbench

## Mounting on the Cabinet

The Qtech Networks RSR series router is designed with the 19-inch standard cabinet. Use the supplied fixing accessory for installation when needed.

QSR-2830 can be mounted on the cabinet using the shipped sunk screw and fixing accessories. Sufficient space (1U as recommended) should be reserved above and beneath the router. The following figures show how to install an QSR-2830 on a rack.

**FIGURE 0-1 BRACKETS**

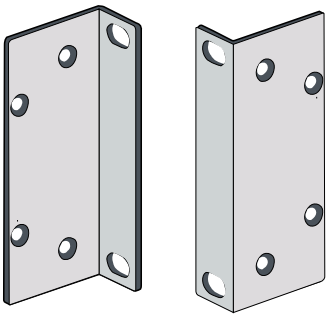

Mounting:

**FIGURE 0-2 STEP1-MOUNTING THE ROUTER ON A RACK**

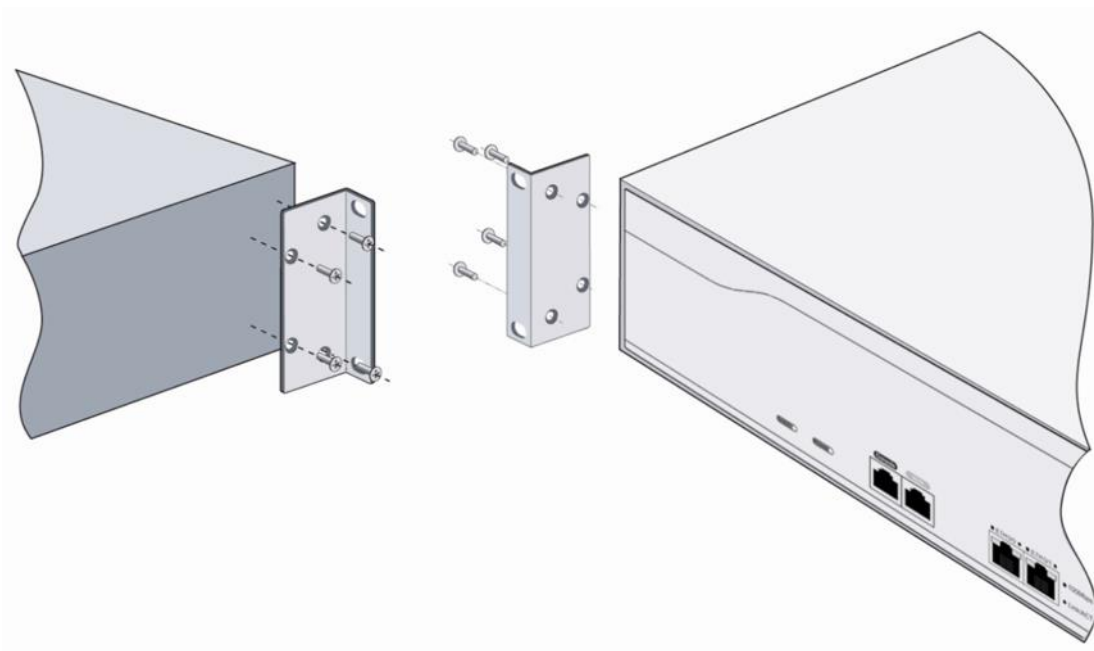

FIGURE 0-3 STEP 2-MOUNTING THE ROUTER ON A RACK



**Note** The figure is only for reference, and the specific object prevails.

## Mounting on the Workbench

In actual application, the standard 19-inch cabinet may be unavailable. In this case, the router is often mounted on a clean workbench. The operation is easy and the requirements are as follows:

- The workbench is stable and is properly grounded.
- The supplied plastic cushion is stuck to the small hole at the bottom of the router and a space of 10 cm is set aside around the router for dissipation.
- No weight is placed on the top of the router.

## Installing the Grounding Cable and the Power Cable

Qtech QSR-2830 series routers support the following AC power supply:

AC: 100–240 VAC; 50 Hz to 60 Hz;

Verify that the power supply meets the requirement.

## Installing the Grounding Cable

The router power cable is composed of three wires. You are recommended use a single-phase power socket with a natural connector or a multifunctional PC power socket. The neutral point of the power supply should be reliably grounded in the building. For common buildings, the neutral points have been buried into the ground during construction and wiring. You must verify if the power supply of the building has been properly grounded.

## Installing the Power Cable

The following table describes the procedure for installing the power cable:

- 1) Verify that the router switch is off. Connect one end of the supplied power cable to the socket on the rear panel of the cabinet and the other end to the AC power socket.
- 2) Switch the router to power on position.
- 3) For the QSR-2830 series router, verify that the PWR indicator on the front panel is on. If so, it indicates that the power cable is correctly connected.

To ensure the tight connection between the power cord and the router, please install the power cord buckle.

- 1) Insert the buckle into the mounting hole for the power cord buckle, as shown in Figure 0-4.

**FIGURE 0-4 INSERTING THE BUCKLE INTO THE MOUNTING HOLE**



- 2) Through the buckle, plug the power cord into the router.

FIGURE 0-5 PLUGGING THE POWER CORD

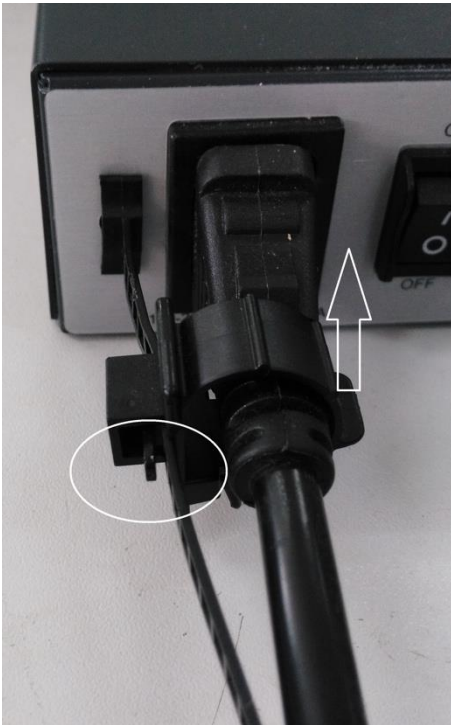

You can move the part circled in Figure 0-5 to adjust the position of the buckle. Do it along the direction indicated by the arrow to stabilize the connector tightly.



**Note** The power supply socket should be installed near the device for convenient plugging.



**Note** Disconnect all pluggable communication networks ends and power distribution system ends before disconnecting the power cables.



**Note** The power cord buckle is provided by Qtech.

---

## Removing the Power Cable

The following table describes the procedure for removing the power cable:

- 1) Switch off the power supply module.
- 2) Loosen the power cord buckle, and then unplug the power cord from the power slot in the power supply module.



## Connecting the Console

Qtech series routers supply an EIA/TIA-232 configuration console for local configuration. This interface enables user to complete the local configuration of the routers.

The following table describes the configuration attributes.

Parameters	Description
Connector	RJ-45
Interface Standard	Asynchronous EIA/TIA-232
Baud Rate	Default: 9600 bps
Supported Services	1. Command line interface 2. Connection to the character terminal

To connect the console port of the router:

Connect one end of the supplied configuration cable to the console port of the router and the other end to the DB-9 male connector used to configure the router. Verify that a Super Terminal is run on the PC.

## Installing Service Modules

Refer to *Chapter 1 Product Overview* for supported models of service modules.



**Caution** Installation described in this section happens during power off. For hot swapping process, please refer to *Configuration Guide*.

---

### Installing Service Modules

- 1) Face the router rear panel.
- 2) Flush the service module interface board and the edge of the opening of the back panel of the router base.
- 3) Push the service module to the router until the interface board closely touches the backplane of the router.
- 4) Tighten the fastening screws on the service module.
- 5) Repeat Step 3 through Step 4 until all the service modules have been installed.



**Caution** For modules supporting hot swapping, you can plug them during power on.

---



**Caution** For modules not supporting hot swapping, you have to turn off the router before plugging the modules.



**Caution** At Step 2 and Step 3, operate gently. A service module should be inserted gently and smoothly. If you find it difficult to push the service module, do not adopt forcible measures. Instead, unplug the service module and check if the SIC module interface board has been aligned with the edge of the opening on the rear panel at the base of the router. Otherwise, the service module may be damaged.

---

## Removing Service Modules

- 1) Face the router rear panel.
- 2) Unplug the cables of the ports on the module to be removed.
- 3) Remove the fastening screws on the two sides of the service module interface board with a Phillips screwdriver.
- 4) Draw the service module to the front of you until the interface board completely disengages from the base of the router.
- 5) Repeat Step 3 and Step 4 until all required service module interface boards have been removed.



**Caution** To remove hot-swappable modules, you do not need to switch off the router, but you need to press the **OFL** button before any further operation.



**Caution** To remove non-hot-swappable modules, you have to turn off the router first.



**Caution** When you have removed a service module and are not going to install another one, install a filler panel in time to protect it against dust and ensure ventilation.



**Caution** When you remove a service module, keep it distant from the passage in the working room to avoid any damage or accident due to bumping during removal.

---

## Troubleshooting Line Modules

Troubleshooting service modules as follows if the router fails to operate after you have installed a service module:

- Check the interface cable of the module to see if the correct cable has been used.
- Observe the interface indicators of various modules to see if the module is working properly.
- In privileged EXEC mode, view interface information. Check whether each service module has accepted configuration and is operational.

## Installing and Removing Power Supply Modules



**Note** The power supply module in this section refers to QSR-M-2830-PWR-AC.

### Installing Power Supply Modules

- 1) Face the router rear panel, as shown in the following figure.

**FIGURE 0-6 REAR PANEL OF THE ROUTER**



- 2) Remove the filler panel, if there is any in the slots for power supply module.

**FIGURE 0-7 SLOTS FOR POWER SUPPLY MODULE**



- 3) Flush the power supply module and the edge of the back panel of the router base.

**FIGURE 0-8 FLUSHING THE MODULE AND THE ROUTER BASE**



- 4) Push the service module to the router until the interface board closely touches the backplane of the router. Tighten the fastening screws on the service module.

**FIGURE 0-9 TIGHTENING THE FASTENING SCREWS**



- 5) Repeat Step 3 through Step 4 until all the service modules have been installed.



**Caution**

Before installing the power supply module, please ensure the module is switched off and free of power cord. Otherwise, damages can be done to operating staff or the router.



**Caution**

At Step 4, operate gently. A power supply module should be inserted gently and smoothly. If you find it difficult to push the module, do not adopt forcible measures. Instead, unplug the module and check if the module has been aligned with the edge of the opening on the rear panel at the base of the router. Otherwise, the service module may be damaged.

---

## Removing Power Supply Modules

- 1) Face the router rear panel.
- 2) Switch off the power supply module and then unplug its power cord.
- 3) Remove the fastening screws on the power supply module with a Phillips screwdriver. Draw the module to the front of you until it completely disengages from the base of the router. Performance of the operating power supply module is not affected.



### Caution

Before removing the power supply module, please ensure the power cord is unplugged from the power slot in the power supply module. Otherwise, damages can be done to operating staff or the router.



### Caution

At Step 3, operate gently. A power supply module should be removed gently and smoothly. If you find it difficult to pull the module, do not adopt forcible measures. Instead, check if the module has been aligned with the edge of the opening on the rear panel at the base of the router. Otherwise, the service module may be damaged.



### Caution

When you have removed a power supply module and are not going to install another one, install a filler panel in time to protect it against dust and ensure ventilation.

---

## Starting and Configuring the Router

### Starting a Router

#### Setting Up the Configuration Environment

When you use the router for the first time, you must configure the router over a console port as follows.

- 1) As shown in the following figure, connect the serial port of a character terminal or PC to the Console port of the network output engine through the standard RS232 cable and the Console. Set up the local configuration environment using the Console port.
- 2) Configure the communication setting parameters of a terminal. If a PC is used, you must run the terminal simulation program, for example, Windows HyperTerminal. The following describes the procedure with the HyperTerminal as example. Run the HyperTerminal software to set up a new connection. Select the serial port to connect the Console port of the network output engine. Set the communication parameters: 9600 for baud rate, eight data bits, one stop bit, no parity check, and no flow control. In addition, select VT100 as the simulation terminal type.
  1. Create a new connection

2. Select the serial port to be connected with the router console
3. Set the communication parameters of the serial port
4. Select a terminal emulation type

After setting up the configuration environment, power on the router.

## Powering up the Router

### *Verification before Power-up*

Verify the following before powering up the router:

- The power cable and the grounding cable are connected correctly.
- The power supply voltage meets the requirement.
- The cable connection is correct and the PC or terminal for configuration is started and set.



**Caution** Before power-up, verify the position of the power switch so that you can cut power supply in time in case of accident.

---

### *Powering up the Router*

- Switch on the power supply.
- Switch the router to the **ON** position.

### *Verification after Power-up*

- The indicators on the front panel operate properly.

Check method: For the QSR-2830, the SYS indicator is solid green when the router is operational after powered-on.

- The configuration terminal displays properly.

When the router is powered up, information on router software self-decompression will be displayed on the terminal.

## Startup Process

When the router is started for the first time, the following information is displayed:

```
Wait for Ctrl+S ...
```



```
#####
#####
#####
#####
#####
#####
#####
#####
#####
#####
#####
#####
#####
#####
#####
#####
#####
#####
#####
#####
#####
#####
#####
```

[OK]

Self decompressing the image succeed and will jump to 0x00010000...

Qtech General Operating System Software

Release Software (tm), Router General Operation System 10.4(3b66) Release(198287),  
Compiled Thu Feb 25 21:12:06 CST 2016 by ngcf67

Copyright (c) 1998-2016s by Qtech Networks.

All Rights Reserved.

Neither Decompileing Nor Reverse Engineering Shall Be Allowed.

\*Feb 12 22:59:50: %MTD\_DRIVER-5-MTD\_NAND\_FOUND: 1 NAND chips(chip size : 268435456)  
detected



```
*Feb 12 23:00:45: %UPGRADE-5-EXTITEM_INSTALLED: File /web/ucs_gb.db has been installed in flash.

*Feb 12 23:01:56: %UPGRADE-5-EXTITEM_INSTALLED: File /web/ucs_big5.db has been installed in flash.

*Feb 12 23:01:56: %UPGRADE-5-EXTITEM_INSTALLED: File /web/update_list.txt has been installed in flash.

*Feb 12 23:01:56: %UPGRADE-5-EXTITEM_INSTALLED: File /web/web_config.text has been installed in flash.

*Feb 12 23:01:59: %DEVICE-5-CHANGED: Device QSR-2830 (1) changed state to up.

*Feb 12 23:02:10: %HOTPLUG-5-INSTALL_OK: Install service module in slot 2 OK.

*Feb 12 23:02:10: %HOTPLUG-5-INSTALL_OK: Install service module in slot 3 OK.

*Feb 12 23:02:10: %HOTPLUG-5-INSTALL_OK: Install service module in slot 4 OK.

*Feb 12 23:02:10: %HOTPLUG-5-INSTALL_OK: Install service module in slot 5 OK.

*Feb 12 23:02:19: %HOTPLUG-5-INSTALL_OK: Install service module in slot 2 OK.

*Feb 12 23:02:19: %HOTPLUG-5-INSTALL_OK: Install service module in slot 3 OK.

*Feb 12 23:02:19: %HOTPLUG-5-INSTALL_OK: Install service module in slot 4 OK.

*Feb 12 23:02:19: %HOTPLUG-5-INSTALL_OK: Install service module in slot 5 OK.

*Feb 12 23:02:25: %SYS-5-COLDSTART: System coldstart.
```

The information may vary with hardware configuration or software version.

You can start to configure the router upon seeing the information

**Note**

When using the router for the first time, it is recommended you set basic parameters using the configuration function.

---

## Configuring the Router

You need to configure a router before using it. For more information about router configuration, see the related Configuration Guide and Command Reference.

## Troubleshooting

### Power Troubleshooting

For the QSR-2830 series, you can determine whether the power system has faults by the PWR indicator on the front panel. For the normal status of the indicator, see the description in Chapter 1. If exceptions occur, verify the following:

- The router power switch is in the on position.
- The power supply switch of the router is in the on position.
- The power cable is connected correctly.
- The power supply meets the requirements.



#### Caution

Do not plug/unplug the power cable when energized. If the check shows everything is normal but the PWR/Status indicator is still off, please contact the local distributor or technical support personnel.

---

### System Troubleshooting

After the router is powered up, the terminal will show the startup messages described in the previous chapter if the system is not operational. If the system configuration fails, the terminal may display no messages or illegible codes.

If the terminal does not display any messages, check:

- Whether the power system is operational.
- Whether the Console cable is properly connected.

If the problem remains, it is probably due to wrong configuration cable or wrong terminal parameter setting. In this case, modify the terminal parameters.

If the terminal displays illegible codes, it is probably because the terminal parameter configurations do not match. In this case, check the terminal parameters: baud rate of 9600; eight data bits; no parity check; one stop bit; no flow control; VT100 for the emulation terminal.



#### Note

If the console port parameters of your router are modified, no message will be displayed on the terminal.

---

## Using the Cables

This chapter describes the use of various cables and converters when applying routers.

### Physical Cable Connection

#### Connecting the E1 Interface

Connecting E1 service module to the Base Band Modem with an E1 cable.

#### *Connecting a DB9F interface on an E1/CE1 service module to the Base Band Modem*

- 1) Through a non-balanced cable
- 2) Through a balanced cable (with crystal connector)
- 3) Through a balanced cable (with crystal connector)

Table : Connecting a DB9F interface on an E1/CE1 service module to the base band modem.

Device	Cable 1	Cable 2	Peer	
QSR-M-2830-2E1/CE1	non-balanced cable	N/A	BNC interface	Base band Modem
	balanced cable (with crystal connector)	N/A	RJ-45 interface	
	balanced cable (with crystal connector)	Straight-through cable		

#### Connecting the Console Interface

The console interface of a switch/router is generally an RJ-45 connector that connects RJ-45 cables through DB9F or connects to the DB9M serial port of PC through the RJ45-DB9 jack matching rollover cable.

Table: Connecting the console interface.

Device	Cable 1	Cable 2	Peer
CONSOLE interface	DB9F-to-RJ45 cable	N/A	PC's DB9M serial interface

### Ordering Information

Qtech Networks provides all previously mentioned cables, except for modem cables shown in the following table are provided by the modem manufacturer.

## Appendix A Switch Lightning Protection

### Installing AC Power Arrester (lightning protection cable row)

The external lightning protection cable row shall be used on the AC power port to prevent the switch from being struck by lightning when the AC power cable is introduced from the outdoor and directly connected to the power port of the switch. The lightning protection cable row is fixed on the cabinet, operating table or the wall in the machine room using the line buttons and screws.

Figure C-1 Schematic Diagram for the Power Arrester

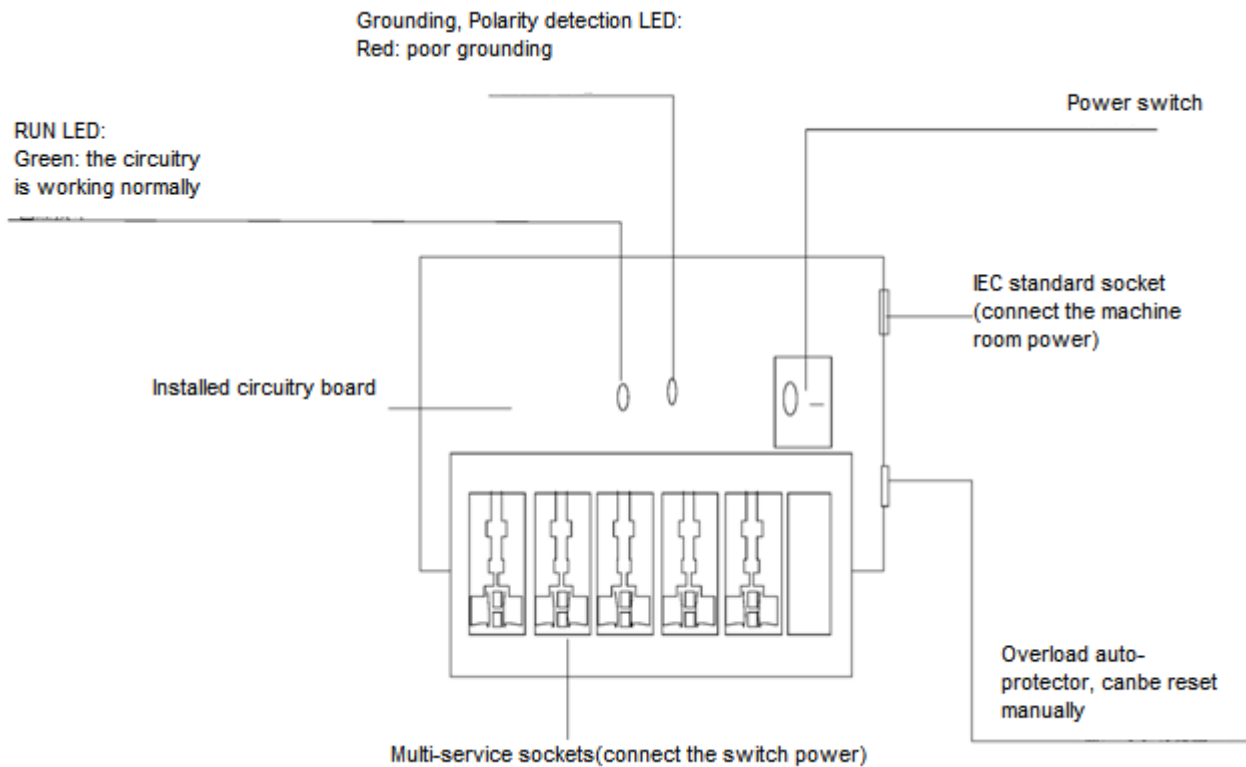

---

The power arrester is not provided and the user shall purchase it to address the practical requirement.

---

Precautions for installation:

- Make sure that the PE terminal of the power arrester has been well-grounded;
- After connecting the switch AC power plug to the socket of the power arrester (lightning protection socket), lightning protection function implements if the RUN LED is Green and the ALARM LED is OFF.
- If the ALARM LED on the power arrester is Red, you shall check what the reason is, poor grounding connection or the reversed connection of the Null and Live lines: Use the multimeter to check the polarity of the power socket for the arrester when the LED is Red, if the N line is on the left and the L line is on the right, the arrester PE terminal is not grounded; if the L line is on the left and the N line is on the right, the polarity of the arrester power cable shall be reversed; if the LED is still Red, it is confirmed that the arrester PE terminal has not been grounded.

### Installing the Ethernet Port Arrester

During the switch usage, the Ethernet port arrester shall be connected to the switch to prevent the switch damage by lightning before the outdoor network cable connects to the switch.

Tools: Cross or straight screwdriver, Multimeter, Diagonal pliers

Installation Steps:

- 1) Tear one side of the protection paper for the double-sided adhesive tape and paste the tape to the framework of the Ethernet port arrester. Tear the other side of the protection paper for the double-sided adhesive tape and paste the Ethernet port arrester to the switch framework. The paste location for the Ethernet port arrester shall be as close to the grounding terminal of the switch.
- 2) Based on the distance of the switch grounding terminal, cut the grounding line for the Ethernet port arrester and firmly tighten the grounding line to the grounding terminal of the switch.
- 3) Use the multimeter to check whether the grounding line for the arrester is in good contact with the switch grounding terminal and the framework.
- 4) According to the description on the Ethernet Port Arrester Hardware Installation Guide, connect the arrester using the adapter cable (note that the external network cable is connected to the end of IN, while the adapter cable connected to the switch is connected to the end of OUT) and observe whether the LED on the board is normal or not.
- 5) Use the nylon button to bundle the power cables.

Figure C-2 Schematic Diagram for the Ethernet port Arrester Installation

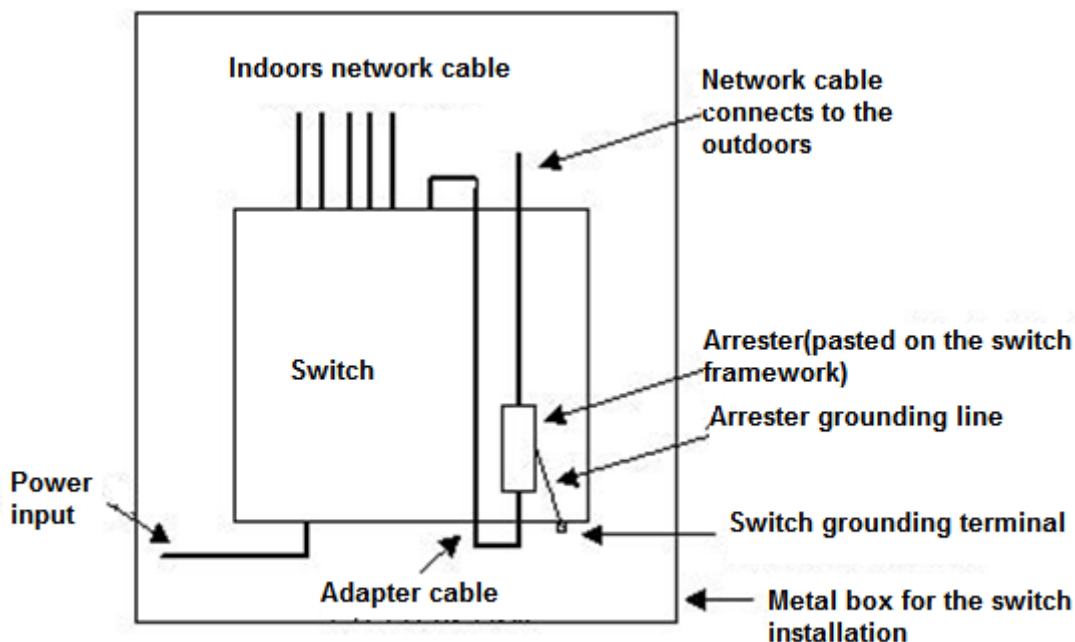

The Ethernet port arrester is only for the 10M/100M copper Ethernet ports with the RJ-45 connector;

The Ethernet port arrester is not provided, the user can purchase them to address their own practical requirements. For the detailed information during the arrester installation, please refer to Ethernet Port Arrester Hardware Installation Guide, which contains the technical specification and the maintenance and installation of the arrester.

You may pay attention to the following conditions during the actual installation to avoid influencing the performance of the Ethernet port arrester:

- Reversed direction of the arrester installation. You shall connect the external network cable to the "IN" end and connect the switch Ethernet port to the "OUT" end.
- Poor arrester grounding. The length of the grounding line should be as short as possible to ensure that it is in good contact with the switch grounding terminal. Use the multimeter to confirm the contact condition after the grounding.
- Incomplete arrester installation. If there is more than one port connected to the peer device on the switch, it needs to install the arresters on all connection ports for the purpose of the lightning protection.

## Appendix B Cabling Recommendations in Installation

When the router is installed in standard 19-inch cabinets, route cable bundles upward or downward along the sides of the rack depending on the actual situation in the equipment room. All cable connectors should be placed at the bottom of the cabinet rather than be exposed outside of the cabinet. Power cords should be routed upward or downward beside the cabinet close to the location of the DC power distribution cabinet, AC power outlet, or lightning protection box.

### Required Minimum Cable Bend Radius

- The minimum bend radius of a power, communication or flat cable should be 5 times the overall diameter of the cable. If the cable is constantly bent, plugged or unplugged, the bend radius should be 7 times the overall diameter.
- The minimum bend radius of a coaxial cable should be 7 times the overall diameter of the cable. If the cable is constantly bent, plugged or unplugged, the bend radius should be 10 times the overall diameter.
- The minimum bend radius of a high-speed cable, such as an SFP+ cable should be 5 times the overall diameter of the cable. If the cable is constantly bent, plugged or unplugged, the bend radius should be 10 times the overall diameter. Required minimum fiber bend radius
- The diameter of a fiber tray to hold fibers cannot be less than 25 times the diameter of the fiber.
- When moving an optical fiber, the bend radius of the fiber should be equal to or greater than 20 times the diameter of the fiber.
- During cabling of an optical fiber, the bend radius of the fiber should be equal to or greater than 10 times the diameter of the fiber.

### Precautions for Cable Bundling

- Before bundling cables, correctly mark labels and stick the labels to cables where appropriate.
- Cables should be neatly and properly bundled, as shown in Figure D-1.

Figure D-1 Bundling Cables

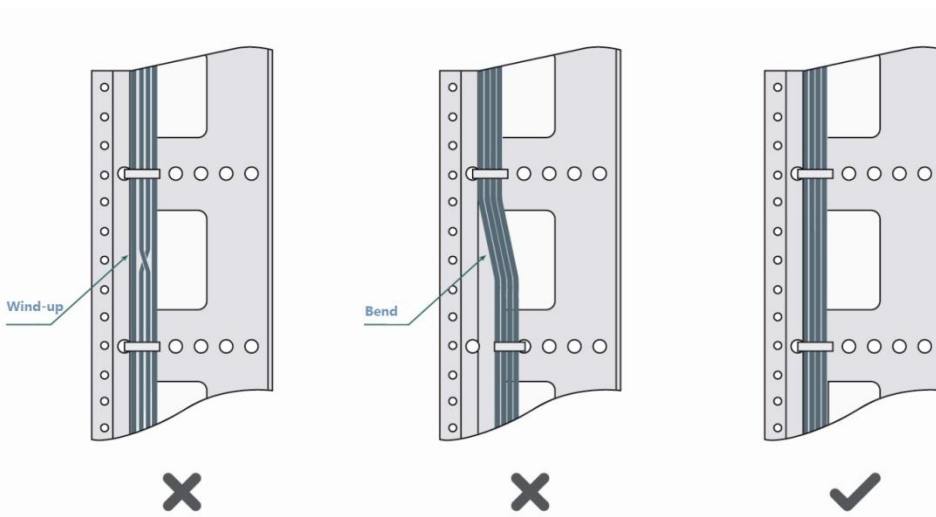

- Route and bundle power, signal, ground cables separately. When the cables are close to each other, cross them. When power cables run parallel to signal cables, the distance between them must be  $b$
- All cable trays and their accessories shall be smooth and free from sharp edges.

- Holes in metal through which cables pass shall have smooth, well-rounded surfaces or be protected with insulating bushings.
- Use proper cable ties to bind cables together. Do not tie two or more cable ties to bind cables.
- Cut off excess cable tie cleanly with no sharp edges after bundling cables, as shown in Figure D-2.

Figure D-2 Cutting off Excess Cable Tie

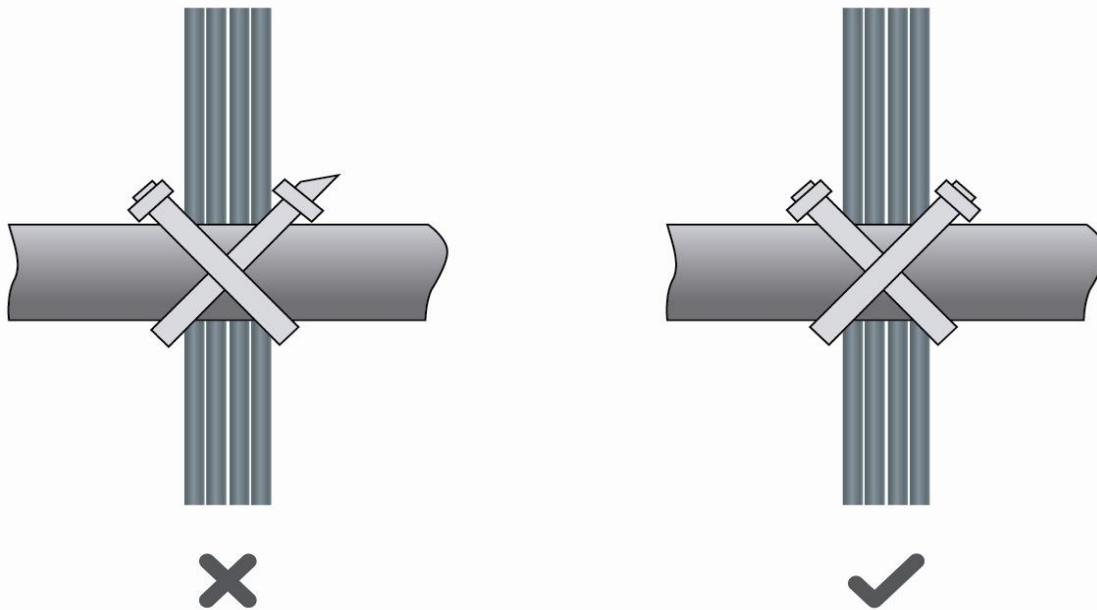

- If cables are to be bent, bind them first but do not tie cable ties within the bend to avoid stress on the cables, which may otherwise cause the wires inside to break, as shown in Figure D-3.

Figure D-3 Do Not Tie Cable Ties within the Bend

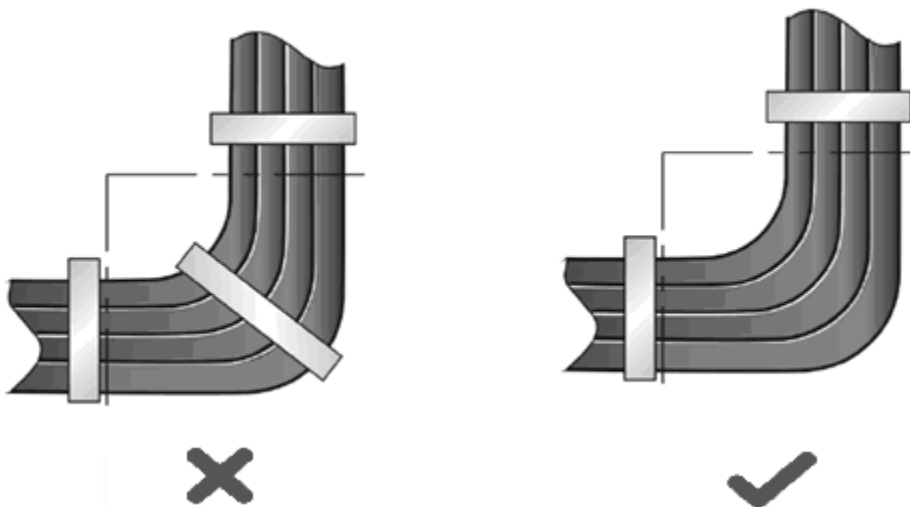

- Wrap up unnecessary or excess cables and bind them to the appropriate rack position, where device operation is not affected and no damages occur to the device and cables during debugging.
- Do not bind power cords to the rails for moving parts.
- Leave a certain length of the cable connecting moving parts, such as the ground wire of the cabinet door, to avoid stress on the cable; When moving parts are in place, ensure the excess cable length shall not contact heat sources, sharp corners or edges. If heat sources are unavoidable, use high-temperature cables instead.
- When using screws to fasten cable lugs, the bolts or nuts shall be tightened and prevented from loosening, as shown in Figure D-4.

Figure D-4 Fastening Cable Lugs



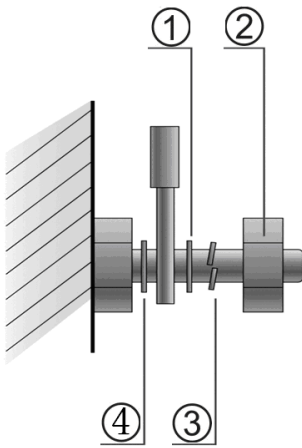

**Note**

- 1. Flat washer
- 2. Nut
- 3. Spring washer
- 4. Flat washer

- When using a stiff cable, fix it near the cable lug to avoid stress on the lug and cable.
- Do not use self-tapping screws to fasten terminals.
- Bundle cables of the same type and running in the same direction into groups. Keep cables clean and straight.
- Cables shall be tied according to the following table.

Diameter of Cable Bundle (mm)	Space between Bundles (mm)
10	80 to 150
10 to 30	150 to 200
30	200 to 300

- Do not tie knots for cables or cable bundles.

The metal parts of the cold-pressed terminal blocks, such as air circuit breakers, shall not be exposed outside of the block